

Table of Contents

| | |
|---|--------|
| 7.1 Organic Liquid Storage Tanks | 7.1-3 |
| 7.1.1 General | 7.1-3 |
| 7.1.1.1 Scope | 7.1-3 |
| 7.1.1.2 Process Description | 7.1-4 |
| 7.1.2 Emission Mechanisms And Control | 7.1-8 |
| 7.1.2.1 Fixed Roof Tanks | 7.1-8 |
| 7.1.2.2 Floating Roof Tanks | 7.1-9 |
| 7.1.3 Emission Estimation Procedures | 7.1-14 |
| 7.1.3.1 Routine Losses From Fixed Roof Tanks | 7.1-15 |
| 7.1.3.2 Routine Losses From Floating Roof Tanks | 7.1-31 |
| 7.1.3.3 Floating Roof Landing Losses | 7.1-37 |
| 7.1.3.4 Tank Cleaning Emissions | 7.1-48 |
| 7.1.3.5 Flashing Loss | 7.1-56 |
| 7.1.3.6 Variable Vapor Space Tanks | 7.1-57 |
| 7.1.3.7 Pressure Tanks | 7.1-58 |
| 7.1.3.8 Variations Of Emission Estimation Procedures | 7.1-58 |
| 7.1.4 Speciation Methodology | 7.1-63 |
| 7.1.5 Source Classification Codes | 7.1-67 |
| 7.1.6 Summary of Major Updates | 7.1-73 |
| Figure 7.1-1. Typical fixed-roof tank | 7.1-74 |
| Figure 7.1-2. External floating roof tank (pontoon type) | 7.1-75 |
| Figure 7.1-3. External floating roof tank (double deck) | 7.1-76 |
| Figure 7.1-4. Internal floating roof tank | 7.1-77 |
| Figure 7.1-5. Domed external floating roof tank | 7.1-78 |
| Figure 7.1-6. Vapor-mounted primary seals | 7.1-79 |
| Figure 7.1-7. Liquid-mounted and mechanical shoe primary seals | 7.1-80 |
| Figure 7.1-8. Secondary rim seals | 7.1-81 |
| Figure 7.1-9. Deck fittings for floating roof tanks | 7.1-82 |
| Figure 7.1-10. Deck fittings for floating roof tanks | 7.1-83 |
| Figure 7.1-11. Slotted and unslotted guidepoles | 7.1-84 |
| Figure 7.1-12. Ladder well | 7.1-85 |
| Figure 7.1-13a. True vapor pressure of crude oils with Reid vapor pressures of 2 to 15 psi | 7.1-86 |
| Figure 7.1-13b. Equation for true vapor pressure of crude oils with Reid vapor pressures of 2 to 15 psi. ⁴ See note at Figure 7.1-13a | 7.1-87 |
| Figure 7.1-14a. True vapor pressure of refined petroleum stocks with Reid vapor pressures of 1 to 20 psi | 7.1-88 |
| Figure 7.1-14b. Equation for true vapor pressure of refined petroleum stocks with Reid vapor pressures of 1 to 20 psi | 7.1-89 |
| Figure 7.1-15. Equations to determine vapor pressure constants A and B for refined petroleum stocks | 7.1-89 |
| Figure 7.1-16. Equations to determine vapor pressure Constants A and B for crude oil stocks | 7.1-89 |
| Figure 7.1-17. Equations for the average daily maximum and minimum liquid surface temperatures | 7.1-90 |
| Figure 7.1-18. Reserved | 7.1-91 |

| | |
|--|---------|
| Figure 7.1-19. Vapor pressure function..... | 7.1-92 |
| Figure 7.1-20. Bottom conditions for landing loss..... | 7.1-93 |
| Figure 7.1-21. Ladder-slotted guidepole combination with ladder sleeve..... | 7.1-93 |
| Figure 7.1-22. Slotted-guidepole with flexible enclosure..... | 7.1-94 |
| Figure 7.1-23. Height of the liquid heel and vapor space under a landed floating roof. | 7.1-95 |
| Figure 7.1-24. Depth of a partial heel in a cone down bottom. | 7.1-96 |
| Table 7.1-1. List Of Abbreviations Used In The Tank Equations | 7.1-97 |
| Table 7.1-2. Properties (M_V , M_L , P_{VA} , W_L) Of Selected Petroleum Liquids..... | 7.1-100 |
| Table 7.1-3. Physical Properties Of Selected Organic Chemicals..... | 7.1-101 |
| Table 7.1-4. Height Of The Liquid Heel And Vapor Space Under A Landed Floating Roof | 7.1-112 |
| Table 7.1-5. LEL Values For Selected Compounds | 7.1-113 |
| Table 7.1-6. Paint Solar Absorptance | 7.1-114 |
| Table 7.1-7. Meteorological Data (T_{AX} , T_{AN} , V , I , P_A) For Selected U.S. Locations | 7.1-115 |
| Table 7.1-8. Rim-Seal Loss Factors, K_{Ra} , K_{Rb} , and n For Floating Roof Tanks..... | 7.1-157 |
| Table 7.1-9. RESERVED | 7.1-159 |
| Table 7.1-10. Average Clingage Factors, C_S | 7.1-159 |
| Table 7.1-11. Typical Number Of Columns As A Function Of Tank Diameter For Internal Floating Roof Tanks With Column Supported Fixed Roofs ^a | 7.1-159 |
| Table 7.1-12. Deck-Fitting Loss Factors, K_{Fa} , K_{Fb} , and m , and Typical Number Of Deck Fittings, N_F .. | 7.1-160 |
| Table 7.1-13. External Floating Roof Tanks: Typical Number Of Vacuum Breakers, N_{vb} , and Deck Drains, N_d | 7.1-163 |
| Table 7.1-14. External Floating Roof Tanks: Typical Number Of Roof Legs, N_l | 7.1-164 |
| Table 7.1-15. Internal Floating Roof Tanks: Typical Number Of Deck Legs, N_j , and Stub Drains, N_d | 7.1-165 |
| Table 7.1-16. Deck Seam Length Factors (S_D) For Typical Deck Constructions For Internal Floating Roof Tanks | 7.1-165 |
| Table 7.1-17. Roof Landing Losses For Internal Or Domed External Floating Roof Tank With A Liquid Heel | 7.1-166 |
| Table 7.1-18. Roof Landing Losses For External Floating Roof Tank With A Liquid Heel | 7.1-167 |
| Table 7.1-19. Roof Landing Losses For All Drain-Dry Tanks..... | 7.1-168 |
| Table 7.1-20. Tank Cleaning Equations – Vapor Space Purge Emissions | 7.1-169 |
| Table 7.1-21. Tank Cleaning Equations – Continued Forced Ventilation Emissions | 7.1-170 |
| 7.1.7 Sample Calculations | 7.1-171 |
| 7.1.8 Historical Equations | 7.1-223 |
| 7.1.8.1 Average Daily Vapor Pressure Range | 7.1-223 |
| 7.1.8.2 Fixed Roof Tank Working Loss | 7.1-223 |
| REFERENCES FOR SECTION 7.1 | 7.1-225 |

7.1 Organic Liquid Storage Tanks

Disclaimer: Emission factors in AP-42 are neither EPA-recommended emission limits (e.g., best available control technology or BACT, or lowest achievable emission rate or LAER) nor standards (e.g., National Emission Standard for Hazardous Air Pollutants or NESHAP, or New Source Performance Standards or NSPS). Use of these factors as source-specific permit limits and/or as emission regulation compliance determinations is NOT recommended by EPA. Because emission factors essentially represent an average of a range of emission rates, approximately half of the subject sources are expected to have emission rates greater than the emission factor, and the other half are expected to have emission rates less than the emission factor. As such, EPA does not recommend using emission factors as limits or standards. This could cause, for example, a permit limit using an AP-42 emission factor resulting in approximately half of the sources being in noncompliance. We recommend source testing be done for the best possible emission values. For more information on the use of emission factors, please refer to the [AP-42 Introduction](#).

7.1.1 General

7.1.1.1 Scope

Section 7.1 presents emissions estimating methodologies for storage tanks of various types and operating conditions. The methodologies are intended for storage tanks that are properly maintained and in normal working condition. The methodologies do not address conditions of deteriorated or otherwise damaged materials of construction, nor do they address operating conditions that differ significantly from the scenarios described herein. To estimate losses that occur from underground gasoline storage tanks at service stations, please see AP-42 Section 5.2, “Transportation and Marketing of Petroleum Liquids.”

Sections 7.1.3.1 and 7.1.3.2 present emissions estimating methodologies for routine emissions from fixed roof tanks and floating roof tanks. Use of the terminology “routine emissions” to refer to standing and working losses applies only for the purposes of this document, and not for any other air quality purposes such as New Source Review (NSR) permitting. The equations for routine emissions were developed to estimate average annual losses for storage tanks, but provisions for applying the equations to shorter periods of time are addressed in Section 7.1.3.8.1. The equations for routine emissions are a function of temperatures that are derived from a theoretical energy transfer model. In order to simplify the calculations, default values were assigned to certain parameters in the energy transfer equations. The accuracy of the resultant equations for an individual tank depends upon how closely that tank fits the assumptions inherent to these default values. The associated uncertainty may be mitigated by using measured values for the liquid bulk temperature. The equations for routine emissions are not intended to include emissions from the following events (these are addressed separately):

- a) To estimate losses that result from the landing of a floating roof. A separate methodology is presented for floating roof landing losses in Section 7.1.3.3.
- b) To estimate losses that result from cleaning a tank. A separate methodology is presented for tank cleaning losses in Section 7.1.3.4.

- c) To estimate losses from variable vapor space tanks. Variable vapor space tanks are discussed in Section 7.1.3.6.
- d) To estimate losses from equipment leaks associated with pressure tanks designed as closed systems without emissions to the atmosphere. Pressure tanks are discussed in Section 7.1.3.7.

Section 7.1.3.8 addresses the following additional scenarios that are outside the scope of the methodologies for routine emissions presented in Sections 7.1.3.1 and 7.1.3.2.

- e) Time periods shorter than one year. Certain assumptions in the equations for routine emissions are based on annual averages, and thus the equations have greater uncertainty for a period of time less than a year. Section 7.1.3.8.1 addresses application of the equations to time periods shorter than one year, with the caveat that a one-month time frame is recommended as the shortest time period for which routine emissions should be estimated using these methodologies.
- f) Internal floating roof tanks with closed vent systems. The equations for routine emissions from internal floating roof tanks assume that the tank has open vents in the fixed roof. Section 7.1.3.8.2 addresses estimation of emissions when an internal floating roof tank has closed pressure/vacuum vents.
- g) Case-specific liquid surface temperature determination. Several parameters pertaining to liquid surface temperature are assigned default values for incorporation into the equations for routine emissions. Section 7.1.3.8.3 presents methodology to account for these parameters as variables in the estimation of emissions from a particular storage tank at a particular location.
- h) Heating cycles in fixed roof tanks. The equations for standing loss from fixed roof tanks are based on a daily cycle of warming and cooling of the vapor space due to heat exchange between the vapor space and ambient air through the shell and roof of the tank. This heat exchange results in daytime expansion and nighttime contraction of vapors in the vapor space, with each expansion causing some portion of the vapors to be expelled from the vapor space. A similar cycle of expansion and contraction of the vapors may be driven by cyclic heating of the bulk liquid. Section 7.1.3.8.4 provides guidance for adapting the equations for fixed roof tank standing loss to the case of cyclic heating of the bulk liquid.

Section 7.1.4 presents calculations for applying Raoult's Law to calculate the contribution of individual chemical species to the total emissions.

Section 7.1.5 presents worked examples, with estimated emissions shown to two significant figures. This level of precision is chosen arbitrarily and may overstate the accuracy of the loss estimates given the uncertainty associated with the multiple parameters affecting emissions from storage tanks.

Section 7.1.6 contains equations that have been used historically to obtain approximate values, but which have been replaced with more accurate equations.

7.1.1.2 Process Description¹⁻³

Storage tanks containing organic liquids can be found in many industries, including (1) petroleum producing and refining, (2) petrochemical and chemical manufacturing, (3) bulk storage and transfer operations, and (4) other industries consuming or producing organic liquids.

Six basic types of designs are used for organic liquid storage tanks: fixed roof (vertical and horizontal), external floating roof, domed external (or covered) floating roof, internal floating roof, variable vapor space, and pressure (low and high). A brief description of each tank is provided below. Loss mechanisms associated with each type of tank are described in Section 7.1.2.

The emission estimating equations presented in Section 7.1 were developed by the American Petroleum Institute (API). API retains the copyright to these equations. API has granted permission for the nonexclusive; noncommercial distribution of this material to governmental and regulatory agencies. However, API reserves its rights regarding all commercial duplication and distribution of its material. Therefore, the material presented in Section 7.1 is available for public use, but the material cannot be sold without written permission from the American Petroleum Institute and the U. S. Environmental Protection Agency.

7.1.1.2.1 Fixed Roof Tanks

A typical vertical fixed roof tank is shown in Figure 7.1-1. This type of tank consists of a cylindrical steel shell with a permanently affixed roof, which may vary in design from cone- or dome-shaped to flat. Losses from fixed roof tanks are caused by changes in temperature, pressure, and liquid level.

Fixed roof tanks are either freely vented or equipped with a pressure/vacuum vent. The latter allows the tanks to operate at a slight internal pressure or vacuum to prevent the release of vapors during small changes in temperature, pressure, or liquid level. Fixed roof tanks may have additional vents or hatches, referred to as emergency vents, to provide increased vent flow capacity in the event of excessive pressure in the tank. Of current tank designs, the fixed roof tank is the least expensive to construct and is generally considered the minimum acceptable equipment for storing organic liquids.

Horizontal fixed roof tanks are constructed for both above-ground and underground service and are usually constructed of steel, steel with a fiberglass overlay, or fiberglass-reinforced polyester. Horizontal tanks are generally small storage tanks with capacities of less than 40,000 gallons. Horizontal tanks are constructed such that the length of the tank is not greater than six times the diameter to ensure structural integrity. Horizontal tanks are usually equipped with pressure-vacuum vents, gauge hatches and sample wells, and manholes to provide access.

The potential emission sources for above-ground horizontal tanks are the same as those for vertical fixed roof tanks. Emissions from underground storage tanks are associated mainly with changes in the liquid level in the tank. Losses due to changes in temperature or barometric pressure are minimal for underground tanks because the surrounding earth limits the diurnal temperature change, and changes in the barometric pressure result in only small losses. However, standing losses from underground gasoline tanks, which can experience relatively fast vapor growth after the ingestion of air and dilution of the headspace, are addressed in Section 5.2 of AP-42.

7.1.1.2.2 External Floating Roof Tanks

A typical external floating roof tank (EFRT) consists of an open-top cylindrical steel shell equipped with a roof that floats on the surface of the stored liquid. The floating roof consists of a deck, deck fittings, and a rim seal system. Floating decks that are currently in use are constructed of welded steel plate and are most commonly of two general types: pontoon or double-deck. Pontoon-type and

double-deck-type external floating roof tanks are shown in Figures 7.1-2 and 7.1-3, respectively. With all types of external floating roof tanks, the roof rises and falls with the liquid level in the tank. External floating decks are equipped with a rim seal system, which is attached to the deck perimeter and contacts the tank wall. The purpose of the floating roof and rim seal system is to reduce evaporative loss of the stored liquid. Some annular space remains between the seal system and the tank wall. The seal system slides against the tank wall as the roof is raised and lowered. The floating deck is also equipped with deck fittings that penetrate the deck and serve operational functions. The external floating roof design is such that routine evaporative losses from the stored liquid are limited to losses from the rim seal system and deck fittings (standing loss) and any liquid on the tank walls that is exposed by the lowering of the liquid level associated with the withdrawal of liquid (working loss). Because of the open-top configuration of this tank, wind effects have a significant impact on evaporative losses from this type of tank.

7.1.1.2.3 Internal Floating Roof Tanks

An internal floating roof tank (IFRT) has both a permanent fixed roof and a floating roof inside. There are two basic types of internal floating roof tanks: tanks in which the fixed roof is supported by vertical columns within the tank, and tanks with a self-supporting fixed roof and no internal support columns. Fixed roof tanks that have been retrofitted to use a floating roof are typically of the first type. External floating roof tanks that have been converted to internal floating roof tanks typically have a self-supporting roof. Newly constructed internal floating roof tanks may be of either type. The deck in internal floating roof tanks rises and falls with the liquid level and either floats directly on the liquid surface (contact deck) or rests on pontoons several inches above the liquid surface (noncontact deck). The majority of aluminum internal floating roofs currently in service have noncontact decks. A typical internal floating roof tank is shown in Figure 7.1-4.

Contact decks include (1) aluminum sandwich panels that are bolted together, with a honeycomb aluminum core floating in contact with the liquid; (2) pan steel decks floating in contact with the liquid, with or without pontoons; and (3) resin-coated, fiberglass reinforced polyester (FRP), buoyant panels floating in contact with the liquid. Variations on these designs are also available. The majority of internal contact floating decks currently in service are aluminum sandwich panel-type or pan steel-type. The FRP decks are less common. The panels of pan steel decks are usually welded together.

Noncontact decks are the most common type currently in use. Typical noncontact decks are constructed of an aluminum deck and an aluminum grid framework supported above the liquid surface by tubular aluminum pontoons or some other buoyant structure. The noncontact decks usually have bolted deck seams.

Installing a floating roof minimizes evaporative losses of the stored liquid. Both contact and noncontact decks incorporate rim seals and deck fittings for the same purposes previously described for external floating roof tanks. Evaporative losses from floating roofs may come from deck fittings, nonwelded deck seams, and the annular space between the deck and tank wall. In addition, these tanks are freely vented by circulation vents at the top of the fixed roof. The vents minimize the possibility of organic vapor accumulation in the tank vapor space in concentrations approaching the flammable range. An internal floating roof tank not freely vented is considered an internal floating roof tank with a closed vent system. Emission estimation methods for such tanks are addressed in Section 7.1.3.8.2.

7.1.1.2.4 Domed External Floating Roof Tanks

Domed external (or covered) floating roof tanks have the heavier type of deck used in external floating roof tanks as well as a fixed roof at the top of the shell like internal floating roof tanks. Domed external floating roof tanks usually result from retrofitting an external floating roof tank with a fixed roof. This type of tank is very similar to an internal floating roof tank with a welded deck and a self-supporting fixed roof. A typical domed external floating roof tank is shown in Figure 7.1-5.

As with the internal floating roof tanks, the function of the fixed roof with respect to emissions is not to act as a vapor barrier, but to block the wind. The estimations of rim seal losses and deck fitting losses include a loss component that is dependent on wind speed and a loss component that is independent of wind speed. When a tank is equipped with a fixed roof, the wind-dependent component is zero due to the blocking of the wind by the fixed roof, leaving only the wind-independent loss component.

The type of fixed roof most commonly used is a self-supporting aluminum dome roof, which is of bolted construction. Like the internal floating roof tanks, these tanks are freely vented by circulation vents at the top and around the perimeter of the fixed roof. The deck fittings and rim seals, however, are identical to those on external floating roof tanks. In the event that the floating deck is replaced with the lighter IFRT-type deck, the tank would then be considered an internal floating roof tank.

The distinction between a domed external floating roof tank and an internal floating roof tank is primarily for purposes of recognizing differences in the deck fittings when estimating emissions. In particular, the domed external floating roof deck typically has significantly taller leg sleeves than are typical of an internal floating roof deck. The longer leg sleeves of the domed external floating roof deck have lower associated emissions than the shorter leg sleeves of the internal floating roof deck. While a domed external floating roof tank is distinct from an internal floating roof tank for purposes of estimating emissions, the domed external floating roof tank would be deemed a type of internal floating roof tank under air regulations that do not separately specify requirements for a domed external floating roof tank.

7.1.1.2.5 Variable Vapor Space Tanks

Variable vapor space tanks are equipped with expandable vapor reservoirs to accommodate vapor volume fluctuations attributable to temperature and barometric pressure changes. Although variable vapor space tanks are sometimes used independently, they are normally connected to the vapor spaces of one or more fixed roof tanks. The two most common types of variable vapor space tanks are lifter roof tanks and flexible diaphragm tanks.

Lifter roof tanks have a telescoping roof that fits loosely around the outside of the main tank wall. The space between the roof and the wall is closed by either a wet seal, which is a trough filled with liquid, or a dry seal, which uses a flexible coated fabric.

Flexible diaphragm tanks use flexible membranes to provide expandable volume. They may be either separate gasholder units or integral units mounted atop fixed roof tanks. A variable vapor space tank that utilizes a flexible diaphragm will emit standing losses to the extent that the flexible diaphragm is permeable or there is leakage through the seam where the flexible diaphragm is attached to the tank wall.

A variable vapor space tank will emit vapors during tank filling when vapor is displaced by liquid, if the tank's vapor storage capacity is exceeded.

7.1.1.2.6 Pressure Tanks

Two classes of pressure tanks are in general use: low pressure (2.5 to 15 psig) and high pressure (higher than 15 psig). Pressure tanks generally are used for storing organic liquids and gases with high vapor pressures and are found in many sizes and shapes, depending on the operating pressure of the tank. Low-pressure tanks are equipped with a pressure/vacuum vent that is set to prevent venting loss from boiling and breathing loss from daily temperature or barometric pressure changes. High-pressure storage tanks can be operated so that virtually no evaporative or working losses occur. In low-pressure tanks, working losses can occur with atmospheric venting of the tank during filling operations. Vapor losses from low-pressure tanks storing non-boiling liquids are estimated in the same manner as for fixed roof tanks, with the vent set pressure accounted for in both the standing and working loss equations.

7.1.2 Emission Mechanisms And Control ²⁻⁸

Emissions from the storage of organic liquids occur because of evaporative loss of the liquid during its storage and as a result of changes in the liquid level. The emission mechanisms vary with tank design, as does the relative contribution of each type of emission mechanism. Emissions from fixed roof tanks are a result of evaporative losses during storage (known as breathing losses or standing losses) and evaporative losses during filling operations (known as working losses). External and internal floating roof tanks are emission sources because of evaporative losses that occur during standing storage and withdrawal of liquid from the tank. Standing losses are a result of evaporative losses through rim seals, deck fittings, and/or deck seams. The loss mechanisms for routine emissions from fixed roof and external and internal floating roof tanks are described in more detail in this section.

7.1.2.1 Fixed Roof Tanks

The two significant types of routine emissions from fixed roof tanks are standing and working losses. The standing loss mechanism for a fixed roof tank is known as breathing, which is the expulsion of vapor from a tank through vapor expansion and contraction that results from changes in temperature and barometric pressure. This loss occurs without any liquid level change in the tank. The emissions estimating methodology presented in Section 7.1 assumes the barometric pressure to be constant, and standing losses from fixed roof tanks are attributed only to changes in temperature. As vapors expand in the vapor space due to warming, the pressure of the vapor space increases and expels vapors from the tank through the vent(s) on the fixed roof. If the venting is of a type that is closed in the absence of pressure, such as a weighted-pallet pressure-vacuum vent, then vapors are assumed to not be expelled until the pressure in the vapor space exceeds the set pressure of the vent.

The evaporative loss from filling is called working loss. Emissions due to filling operations are the result of an increase in the liquid level in the tank. As the liquid level increases, the pressure inside the vapor space increases and vapors are expelled from the tank through the vent(s) on the fixed roof as described above for standing loss. No emissions are attributed to emptying, in that the increasing size of the vapor space during emptying is assumed to exceed the rate at which evaporation increases the volume of vapors. That is, it would be expected that flow through the vents during emptying would be into the tank, and thus there are no emissions actually occurring during emptying of a fixed roof tank.

A third type of emissions from fixed roof tanks is commonly referred to as flashing losses. This emission type is not an evaporative loss, but rather involves entrained gases bubbling out of solution when a liquid stream experiences a pressure drop upon introduction into a storage tank. As such, it occurs only in storage tanks that receive pressurized liquid streams containing entrained gases. This scenario is typical of storage tanks receiving liquids from a separator in oil and gas production operations, but does not typically occur at downstream facilities. Flashing losses are discussed in Section 7.1.3.5, but guidance for estimating flashing losses is beyond the scope of this section.

Fixed roof tank emissions from standing and working vary as a function of tank capacity, vapor pressure of the stored liquid, utilization rate of the tank, and atmospheric conditions at the tank location.

Several methods are used to control emissions from fixed roof tanks. Emissions from fixed roof tanks can be controlled by installing an internal floating roof and seals to minimize evaporation of the product being stored. The control efficiency of this method ranges from 60 to 99 percent, depending on the type of roof and seals installed and on the type of organic liquid stored.

Fixed roof tank emissions may also be reduced by increasing the vent set pressure, and routine emissions may be eliminated if the vent set pressure is higher than the pressure that develops in the vapor space during normal operations. See Section 7.1.3.7 for a discussion of estimating emissions from pressure tanks. However, the structural design of most storage tanks would not normally accommodate internal pressures of the magnitude required to significantly reduce emissions, and thus vent set pressures should not be altered without consideration of the tank design including all appropriate safety factors. Subjecting a storage tank to greater pressure or vacuum than that for which the tank was designed could potentially result in failure of the tank.

Vapor balancing is another means of emission control. Vapor balancing is probably most common in the filling of tanks at gasoline service stations. As the storage tank is filled, the vapors expelled from the storage tank are directed to the emptying gasoline tanker truck. The truck then transports the vapors to a centralized station where a vapor recovery or control system may be used to control emissions. Vapor balancing can have control efficiencies as high as 90 to 98 percent if the vapors are subjected to vapor recovery or control. If the truck vents the vapor to the atmosphere instead of to a recovery or control system, no control is achieved.

Vapor recovery systems collect emissions from storage tanks and convert them to liquid product. Several vapor recovery procedures may be used, including vapor/liquid absorption, vapor compression, vapor cooling, vapor/solid adsorption, or a combination of these.

Vapors from fixed roof tanks may also be collected and combusted. There are several types of units at facilities used to accomplish this, including various types of flares and thermal oxidation units.

7.1.2.2 Floating Roof Tanks

Routine emissions from floating roof tanks are the sum of working losses and standing losses. The working loss mechanism for a floating roof tank is also known as withdrawal loss, in that it occurs as the liquid level, and thus the floating roof, is lowered rather than raised. Some liquid remains on the inner tank wall surface and evaporates. For an internal floating roof tank that has a column supported fixed roof, some liquid also clings to the columns and evaporates. Evaporative loss occurs until the tank

is filled and the exposed surfaces are again covered. Standing losses from floating roof tanks include rim seal and deck fitting losses for floating roof tanks with welded decks and include deck seam losses for constructions other than welded decks. Both the working and standing loss mechanisms for floating roof tanks pertain to the accumulation of vapors in the headspace above the floating roof. It is assumed that vapors in the headspace will eventually be expelled from the tank, but this emission estimating methodology does not address the rate or time at which the vapors actually leave the tank.

Rim seal losses can occur through many complex mechanisms, but for external floating roof tanks, the majority of rim seal vapor losses have been found to be wind induced. No dominant wind loss mechanism has been identified for internal floating roof or domed external floating roof tank rim seal losses. Losses can also occur due to permeation of the rim seal material by the vapor or via a wicking effect of the liquid, but permeation of the rim seal material generally does not occur if the correct seal fabric is used. Testing has indicated that breathing, solubility, and wicking loss mechanisms are small in comparison to the wind-induced loss. The rim seal factors presented in this section incorporate all types of losses.

The rim seal system is used to allow the floating roof to rise and fall within the tank as the liquid level changes. The rim seal system also helps to fill the annular space between the rim and the tank shell and therefore minimize evaporative losses from this area. A rim seal system may consist of just a primary seal or a primary and a secondary seal, which is mounted above the primary seal. Examples of primary and secondary seal configurations are shown in Figures 7.1-6, 7.1-7, and 7.1-8.

The primary seal serves as a vapor conservation device by closing the annular space between the edge of the floating deck and the tank wall. Three basic types of primary seals are used on floating roofs: mechanical (metallic) shoe, resilient filled (nonmetallic), and flexible wiper seals. Some primary seals on external floating roof tanks are protected by a weather shield. Weather shields may be of metallic, elastomeric, or composite construction and provide the primary seal with longer life by protecting the primary seal fabric from deterioration due to exposure to weather, debris, and sunlight. Mechanical shoe seals, resilient filled seals, and wiper seals are discussed below.

A mechanical shoe seal uses a light-gauge metallic band as the sliding contact with the shell of the tank, as shown in Figure 7.1-7. The band is formed as a series of sheets (shoes) which are joined together to form a ring and are held against the tank shell by a mechanical device. The shoes are normally 3 to 5 feet deep when used on an external floating roof and are often shorter when used on an internal floating roof. Expansion and contraction of the ring can be provided for as the ring passes over shell irregularities or rivets by jointing narrow pieces of fabric into the ring or by crimping the shoes at intervals. The bottoms of the shoes extend below the liquid surface to confine the rim vapor space between the shoe and the floating deck.

The rim vapor space, which is bounded by the shoe, the rim of the floating deck, and the liquid surface, is sealed from the atmosphere by bolting or clamping a coated fabric, called the primary seal fabric, which extends from the shoe to the rim to form an "envelope". Two locations are used for attaching the primary seal fabric. The fabric is commonly attached to the top of the shoe and the rim of the floating deck. To reduce the rim vapor space, the fabric can be attached to the shoe and the floating deck rim near the liquid surface. Rim vents can be used to relieve any excess pressure or vacuum in the vapor space.

A resilient filled seal can be mounted to eliminate the vapor space between the rim seal and liquid surface (liquid mounted) or to allow a vapor space between the rim seal and the liquid surface (vapor mounted). Both configurations are shown in Figures 7.1-6 and 7.1-7. Resilient filled seals work because of the expansion and contraction of a resilient material to maintain contact with the tank shell while accommodating varying annular rim space widths. These rim seals allow the roof to move up and down freely, without binding.

Resilient filled seals typically consist of a core of open-cell foam encapsulated in a coated fabric. The seals are attached to a mounting on the deck perimeter and extend around the deck circumference. Polyurethane-coated nylon fabric and polyurethane foam are commonly used materials. For emission control, it is important that the attachment of the seal to the deck and the radial seal joints be vapor-tight and that the seal be in substantial contact with the tank shell.

Wiper seals generally consist of a continuous annular blade of flexible material fastened to a mounting bracket on the deck perimeter that spans the annular rim space and contacts the tank shell. This type of seal is depicted in Figure 7.1-6. New tanks with wiper seals may have dual wipers, one mounted above the other. The mounting is such that the blade is flexed, and its elasticity provides a sealing pressure against the tank shell.

Wiper seals are vapor mounted; a vapor space exists between the liquid stock and the bottom of the seal. For emission control, it is important that the mounting be vapor-tight, that the seal extend around the circumference of the deck and that the blade be in substantial contact with the tank shell. Two types of materials are commonly used to make the wipers. One type consists of a cellular, elastomeric material tapered in cross section with the thicker portion at the mounting. Rubber is a commonly used material; urethane and cellular plastic are also available. All radial joints in the blade are joined. The second type of material that can be used is a foam core wrapped with a coated fabric. Polyurethane on nylon fabric and polyurethane foam are common materials. The core provides the flexibility and support, while the fabric provides the vapor barrier and wear surface.

A secondary seal may be used to provide some additional evaporative loss control over that achieved by the primary seal. Secondary seals can be either flexible wiper seals or resilient filled seals. For mechanical shoe primary seals, two configurations of secondary seals are available: shoe mounted and rim mounted, as shown in Figure 7.1-8. Rim mounted secondary seals are more effective in reducing losses than shoe mounted secondary seals because they cover the entire rim vapor space. For internal floating roof tanks, the secondary seal is mounted to an extended vertical rim plate, above the primary seal, as shown in Figure 7.1-8. However, for some floating roof tanks, using a secondary seal further limits the tank's operating capacity due to the need to keep the seal from interfering with fixed roof rafters or to keep the secondary seal in contact with the tank shell when the tank is filled.

The deck fitting losses from floating roof tanks can be explained by the same mechanisms as the rim seal losses. While the relative contribution of each mechanism to the total emissions from a given deck fitting is not known, emission factors were developed for individual deck fittings by testing, thereby accounting for the combined effect of all the mechanisms.

Numerous fittings pass through or are attached to floating roof decks to accommodate structural support components or allow for operational functions. Internal floating roof deck fittings are typically of different configuration than those for external floating roof decks. Rather than having tall

housings to avoid rainwater entry, internal floating roof deck fittings tend to have lower profile housings to minimize the potential for the fitting to contact the fixed roof when the tank is filled. Deck fittings can be a source of evaporative loss when they require openings in the deck. The most common components that require openings in the deck are described below.

1. Access hatches. An access hatch is an opening in the deck with a peripheral vertical well that is large enough to provide passage for workers and materials through the deck for construction or servicing. Attached to the opening is a removable cover that may be bolted and/or gasketed to reduce evaporative loss. On internal floating roof tanks with noncontact decks, the well should extend down into the liquid to seal off the vapor space below the noncontact deck. A typical access hatch is shown in Figure 7.1-9.

2. Gauge-floats. A gauge-float is used to indicate the level of liquid within the tank. The float rests on the liquid surface and is housed inside a well that is closed by a cover. The cover may be bolted and/or gasketed to reduce evaporation loss. As with other similar deck penetrations, the well extends down into the liquid on noncontact decks in internal floating roof tanks. A typical gauge-float and well are shown in Figure 7.1-9.

3. Gauge-hatch/sample ports. A gauge-hatch/sample port consists of a pipe sleeve through the deck for hand-gauging or sampling of the stored liquid. The gauge-hatch/sample port is usually located beneath the gauger's platform, which is mounted on top of the tank shell. A cover may be attached to the top of the opening, and the cover may be equipped with a gasket to reduce evaporative losses. A cord may be attached to the cover so that the cover can be opened from the platform. Alternatively, the opening may be covered with a slit-fabric seal. A funnel may be mounted above the opening to guide a sampling device or gauge stick through the opening. A typical gauge-hatch/sample port is shown in Figure 7.1-9.

4. Rim vents. Rim vents are used on tanks equipped with a seal design that creates a vapor pocket in the seal and rim area, such as a mechanical shoe seal. A typical rim vent is shown in Figure 7.1-10. The vent is used to release any excess pressure that is present in the vapor space bounded by the primary-seal shoe and the floating roof rim and the primary seal fabric and the liquid level. Rim vents usually consist of weighted pallets that rest over the vent opening.

5. Deck drains. Currently two types of deck drains are in use (closed and open deck drains) to remove rainwater from the floating deck. Open deck drains can be either flush or overflow drains. Both types of open deck drains consist of a pipe that extends below the deck to allow the rainwater to drain into the stored liquid. Only open deck drains are subject to evaporative loss. Flush drains are flush with the deck surface. Overflow drains are elevated above the deck surface. Typical overflow and flush deck drains are shown in Figure 7.1-10. Overflow drains are used to limit the maximum amount of rainwater that can accumulate on the floating deck, providing emergency drainage of rainwater if necessary. Closed deck drains carry rainwater from the surface of the deck through a flexible hose or some other type of piping system that runs through the stored liquid prior to exiting the tank. The rainwater does not come in contact with the liquid, so no evaporative losses result. Overflow drains are usually used in conjunction with a closed drain system to carry rainwater outside the tank.

6. Deck legs. Deck legs are used to prevent damage to fittings underneath the deck and to allow for tank cleaning or repair, by holding the deck at a predetermined distance off the tank bottom. These

supports consist of adjustable or fixed legs attached to the floating deck or hangers suspended from the fixed roof. For adjustable legs or hangers, the load-carrying element may pass through a well or sleeve into the deck. With noncontact decks, the well should extend into the liquid. Evaporative losses may occur in the annulus between the deck leg and its sleeve. A typical deck leg is shown in Figure 7.1-10.

7. Unslotted guidepoles and wells. A guidepole is an antirotational device that is fixed to the top and bottom of the tank, passing through a well in the floating roof. The guidepole is used to prevent adverse movement of the roof and thus damage to deck fittings and the rim seal system. In some cases, an unslotted guidepole is used for gauging purposes, but there is a potential for differences in the pressure, level, and composition of the liquid inside and outside of the guidepole. A typical guidepole and well are shown in Figure 7.1-11.

8. Slotted (perforated) guidepoles and wells. The function of the slotted guidepole is similar to the unslotted guidepole but also has additional features. Perforated guidepoles can be either slotted or drilled hole guidepoles. A typical slotted guidepole and well are shown in Figure 7.1-11. As shown in this figure, the guide pole is slotted to allow stored liquid to enter. The same can be accomplished with drilled holes. The liquid entering the guidepole has the same composition as the remainder of the stored liquid, and is at the same liquid level as the liquid in the tank. Representative samples can therefore be collected from the slotted or drilled hole guidepole. Evaporative loss from the guidepole can be reduced by some combination of modifying the guidepole or well with the addition of gaskets, sleeves, or enclosures or placing a float inside the guidepole, as shown in Figures 7.1-11 and 7.1-22. Guidepoles are also referred to as gauge poles, gauge pipes, or stilling wells.

9. Vacuum breakers. A vacuum breaker equalizes the pressure of the vapor space across the deck as the deck is either being landed on or floated off its legs. A typical vacuum breaker is shown in Figure 7.1-10. As depicted in this figure, the vacuum breaker consists of a well with a cover. Attached to the underside of the cover is a guided leg long enough to contact the tank bottom as the floating deck approaches. When in contact with the tank bottom, the guided leg mechanically opens the breaker by lifting the cover off the well; otherwise, the cover closes the well. The closure may be gasketed or ungasketed. Because the purpose of the vacuum breaker is to allow the free exchange of air and/or vapor, the well does not extend appreciably below the deck. While vacuum breakers have historically tended to be of the leg-actuated design described above, they may also be vacuum actuated similar to the pressure/vacuum vent on a fixed roof tank such that they do not begin to open until the floating roof has actually landed. In some cases, this is achieved by replacing the rim vent described above with a pressure/vacuum vent.

Fittings typically used only on internal floating roof tanks include column wells, ladder wells, and stub drains.

1. Columns and wells. Some fixed-roof designs are normally supported from inside the tank by means of vertical columns, which necessarily penetrate an internal floating deck. (Some fixed roofs are entirely self-supporting from the perimeter of the roof and, therefore, have no interior support columns.) Column wells are similar to unslotted guide pole wells on external floating roofs. Columns are made of pipe with circular cross sections or of structural shapes with irregular cross sections (built-up). The number of columns varies with tank diameter, from a minimum of 1 to over 50 for very large diameter tanks. A typical fixed roof support column and well are shown in Figure 7.1-9.

The columns pass through deck openings via peripheral vertical wells. With noncontact decks, the well should extend down into the liquid stock. Generally, a closure device exists between the top of the well and the column. Several proprietary designs exist for this closure, including sliding covers and fabric sleeves, which must accommodate the movements of the deck relative to the column as the liquid level changes. A sliding cover rests on the upper rim of the column well (which is normally fixed to the deck) and bridges the gap or space between the column well and the column. The cover, which has a cutout, or opening, around the column slides vertically relative to the column as the deck raises and lowers. At the same time, the cover may slide horizontally relative to the rim of the well to accommodate out-of-plumbness of the column. A gasket around the rim of the well reduces emissions from this fitting. A flexible fabric sleeve seal between the rim of the well and the column (with a cutout or opening, to allow vertical motion of the seal relative to the columns) similarly accommodates limited horizontal motion of the deck relative to the column.

2. Ladders and wells. Some tanks are equipped with internal ladders that extend from a manhole in the fixed roof to the tank bottom. The deck opening through which the ladder passes is constructed with similar design details and considerations to deck openings for column wells, as previously discussed. A typical ladder well is shown in Figure 7.1-12.

Tanks are sometimes equipped with a ladder-slotted guidepole combination, in which one or both legs of the ladder is a slotted pipe that serves as a guidepole for purposes such as level gauging and sampling. A ladder-slotted guidepole combination is shown in Figure 7.1-21 with a ladder sleeve to reduce emissions.

3. Stub drains. Bolted internal floating roof decks are typically equipped with stub drains to allow any stored product that may be on the deck surface to drain back to the underside of the deck. The drains are attached so that they are flush with the upper deck. Stub drains are approximately 1 inch in diameter and extend down into the product on noncontact decks. A typical flush stub drain is shown in Figure 7.1-10. Stub drains may be equipped with floating balls to reduce emissions. The floating ball acts as a check valve, in that it remains covering the stub drain unless liquid is present to lift it.

Deck seams in internal floating roof tanks are a source of emissions to the extent that these seams may not be completely vapor tight if the deck is not welded. A weld sealing a deck seam does not have to be structural (i.e., may be a seal weld) to constitute a welded deck seam for purposes of estimating emissions, but a deck seam that is bolted or otherwise mechanically fastened and sealed with elastomeric materials or chemical adhesives is not a welded seam. Generally, the same loss mechanisms for deck fittings apply to deck seams. The predominant mechanism depends on whether or not the deck is in contact with the stored liquid. The deck seam loss equation accounts for the effects of all contributing loss mechanisms.

7.1.3 Emission Estimation Procedures

The following section presents the emission estimation procedures for vertical and horizontal fixed roof, external floating roof, domed external floating roof, and internal floating roof tanks. These procedures are valid for all volatile organic liquids and chemical mixtures. It is important to note that in all the emission estimation procedures the physical properties of the vapor do not include the noncondensibles in the atmosphere but only refer to the volatile components of the stored liquid. For example, the vapor-phase molecular weight is determined from the weighted average of the evaporated

components of the stored liquid and does not include the contribution of atmospheric gases such as nitrogen and oxygen. To aid in the emission estimation procedures, a list of variables with their corresponding definitions was developed and is presented in Table 7.1-1.

The factors presented in AP-42 are those that are currently available and have been reviewed and approved by the U. S. Environmental Protection Agency. As storage tank equipment vendors design new floating decks and equipment, new emission factors may be developed based on that equipment. If the new emission factors are reviewed and approved, the emission factors will be added to AP-42 during the next update.

The emission estimation procedures outlined in this chapter have been used as the basis for the development of a software program to estimate emissions from storage tanks. The software program entitled "TANKS" is available through the U. S. Environmental Protection Agency website. While this software does not address all of the scenarios described in this chapter, known errors have been corrected and a new version, TANKS 5.1, is now available.

There are also commercially available storage tank emissions estimation software programs. Users of these programs are advised to understand the extent of agreement with AP-42 Chapter 7 calculation methodology and assume responsibility for the accuracy of the output as they have not been reviewed or approved by the EPA.

7.1.3.1 Routine Losses From Fixed Roof Tanks ^{8-14,22}

The following equations, provided to estimate standing and working loss emissions, apply to tanks with vertical cylindrical shells and fixed roofs and to tanks with horizontal cylindrical shells. These tanks must be substantially liquid- and vapor-tight. The equations are not intended to be used in estimating losses from tanks which have air or other gases injected into the liquid, or which store unstable or boiling stocks or mixtures of hydrocarbons or petrochemicals for which the vapor pressure is not known or cannot be readily predicted. Tanks containing aqueous mixtures in which phase separation has occurred, resulting in a free layer of oil or other volatile materials floating on top of the water, should have emissions estimated on the basis of properties of the free top layer.

Total routine losses from fixed roof tanks are equal to the sum of the standing loss and working loss:

$$L_T = L_S + L_W \quad (1-1)$$

where:

- L_T = total routine losses, lb/yr
- L_S = standing losses, lb/yr, see Equation 1-2
- L_W = working losses, lb/yr, see Equation 1-37

7.1.3.1.1 Standing Loss

The standing loss, L_S , for a fixed roof tank refers to the loss of stock vapors as a result of tank vapor space breathing. Fixed roof tank standing losses can be estimated from Equation 1-2.

$$L_S = 365 V_V W_V K_E K_S \quad (1-2)$$

where:

- L_S = standing loss, lb/yr
- V_V = vapor space volume, ft³, see Equation 1-3
- W_V = stock vapor density, lb/ft³
- K_E = vapor space expansion factor, per day
- K_S = vented vapor saturation factor, dimensionless
- 365 = constant, the number of daily events in a year, (days/year)

Tank Vapor Space Volume, V_V - The tank vapor space volume is calculated using the following equation:

$$V_V = \left(\frac{\pi}{4} D^2 \right) H_{VO} \quad (1-3)$$

where:

- V_V = vapor space volume, ft³
- D = tank diameter, ft, see Equation 1-14 for horizontal tanks
- H_{VO} = vapor space outage, ft, see Equation 1-18

The standing loss equation can be simplified by combining Equation 1-2 with Equation 1-3. The result is Equation 1-4.

$$L_S = 365 K_E \left(\frac{\pi}{4} D^2 \right) H_{VO} K_S W_V \quad (1-4)$$

where:

- L_S = standing loss, lb/yr
- K_E = vapor space expansion factor, per day, see Equation 1-5, 1-12, or 1-13
- D = diameter, ft, see Equation 1-14 for horizontal tanks
- H_{VO} = vapor space outage, ft, see Equation 1-18; use $H_E/2$ from Equation 1-15 for horizontal tanks
- K_S = vented vapor saturation factor, dimensionless, see Equation 1-23
- W_V = stock vapor density, lb/ft³, see Equation 1-24
- 365 = constant, the number of daily events in a year, (days/year)

Vapor Space Expansion Factor, K_E

The calculation of the vapor space expansion factor, K_E , depends upon the properties of the liquid in the tank and the breather vent settings, as shown in Equation 1-5. As shown in the equation, K_E is greater than zero. If K_E is less than zero, standing losses will not occur. In that K_E represents the fraction of vapors in the vapor space that are expelled by a given increase in temperature, a value of 1 would indicate that the entire vapor space has been expelled. Thus the value of K_E must be less than 1, in that it is not physically possible to expel more than 100% of what is present to begin with.

$$0 < K_E \leq 1$$

$$K_E = \frac{\Delta T_V}{T_{LA}} + \frac{\Delta P_V - \Delta P_B}{P_A - P_{VA}} \quad (1-5)$$

where:

ΔT_V = average daily vapor temperature range, °R; see Note 1 to Equation 1-5

ΔP_V = average daily vapor pressure range, psi; see Note 2 to Equation 1-5

ΔP_B = breather vent pressure setting range, psi; see Note 3 to Equation 1-5

P_A = atmospheric pressure, psia

P_{VA} = vapor pressure at average daily liquid surface temperature, psia; see Note 1 to Equation 1-24 and Note 2 to Equation 1-24

T_{LA} = average daily liquid surface temperature, °R; see Note 3 to Equation 1-24

Notes on Equation 1-5:

Note 1 to Equation 1-5. The average daily vapor temperature range, ΔT_V , refers to the daily temperature range of the tank vapor space averaged over all the days in the given period of time, such as one year, and should not be construed as being applicable to an individual day. The average daily vapor temperature range is calculated for an uninsulated tank using Equation 1-6.

$$\Delta T_V = \left(1 - \frac{0.8}{2.2 (H_S/D) + 1.9} \right) \Delta T_A + \frac{0.042\alpha_R I + 0.026(H_S/D)\alpha_S I}{2.2 (H_S/D) + 1.9} \quad (1-6)$$

where:

ΔT_V = average daily vapor temperature range, °R

H_S = tank shell height, ft

D = tank diameter, ft,

ΔT_A = average daily ambient temperature range, °R; see Note 4 to Equation 1-5

α_R = tank roof surface solar absorptance, dimensionless; see Table 7.1-6

α_S = tank shell surface solar absorptance, dimensionless; see Table 7.1-6

I = average daily total insolation factor, Btu/ft² d; see Table 7.1-7.

API assigns a default value of $H_S/D = 0.5$ and an assumption of $\alpha_R = \alpha_S$, resulting in the simplified equation shown below for an uninsulated tank:²²

$$\Delta T_V = 0.7 \Delta T_A + 0.02 \alpha I \quad (1-7)$$

where:

α = average tank surface solar absorptance, dimensionless

For purposes of estimating emissions, a storage tank should be deemed insulated only if the roof and shell are both sufficiently insulated so as to minimize heat exchange with ambient air. If only

the shell is insulated, and not the roof, the temperature equations are independent of H_s/D . Also, there likely will be sufficient heat exchange through the roof such that Equation 1-7 would be applicable.

A more accurate method of accounting for the average daily vapor temperature range, ΔT_v , in partially insulated scenarios is given below. When the tank shell is insulated but the tank roof is not, heat gain to the tank from insolation is almost entirely through the tank roof and thus the liquid surface temperature is not sensitive to H_s/D .

$$\Delta T_v = 0.6 \Delta T_A + 0.02 \alpha_R I \quad (1-8)$$

In the case of a fully insulated tank maintained at constant temperature, the average daily vapor temperature range, ΔT_v , should be taken as zero. This assumption that ΔT_v is equal to zero addresses only temperature differentials resulting from the diurnal ambient temperature cycle. In the case of cyclic heating of the bulk liquid, see Section 7.1.3.8.4.

Note 2 on Equation 1-5. The average daily vapor pressure range, ΔP_v , refers to the daily vapor pressure range at the liquid surface temperature averaged over all the days in the given period of time, such as one year, and should not be construed as being applicable to an individual day. The average daily vapor pressure range can be calculated using the following equation:

$$\Delta P_v = P_{vx} - P_{vn} \quad (1-9)$$

where:

ΔP_v = average daily vapor pressure range, psia

P_{vx} = vapor pressure at the average daily maximum liquid surface temperature, psia; see Note 5 to Equation 1-5

P_{vn} = vapor pressure at the average daily minimum liquid surface temperature, psia; see Note 5 to Equation 1-5

See Section 7.1.6.1 for a more approximate equation for ΔP_v that was used historically, but which is no longer recommended.

In the case of a fully insulated tank maintained at constant temperature, the average daily vapor pressure range, ΔP_v , should be taken as zero, as discussed for the vapor temperature range in Note 1 to Equation 1-5.

Note 3 on Equation 1-5. The breather vent pressure setting range, ΔP_b , is calculated using the following equation:

$$\Delta P_b = P_{BP} - P_{BV} \quad (1-10)$$

where:

ΔP_b = breather vent pressure setting range, psig

P_{BP} = breather vent pressure setting, psig

P_{BV} = breather vent vacuum setting, psig

If specific information on the breather vent pressure setting and vacuum setting is not available, assume 0.03 psig for P_{BP} and -0.03 psig for P_{BV} as typical values. If the fixed roof tank is of bolted or riveted construction in which the roof or shell plates are not vapor tight, assume that $\Delta P_B = 0$, even if a breather vent is used.

Note 4 on Equation 1-5. The average daily ambient temperature range, ΔT_A , refers to the daily ambient temperature range averaged over all of the days in the given period of time, such as one year, and should not be construed as being applicable to an individual day. The average daily ambient temperature range is calculated using the following equation:

$$\Delta T_A = T_{AX} - T_{AN} \quad (1-11)$$

where:

ΔT_A = average daily ambient temperature range, °R

T_{AX} = average daily maximum ambient temperature, °R

T_{AN} = average daily minimum ambient temperature, °R

Table 7.1-7 gives historical values of T_{AX} and T_{AN} in degrees Fahrenheit for selected cities in the United States. These values are converted to degrees Rankine by adding 459.67.

Note 5 on Equation 1-5. The vapor pressures associated with the average daily maximum and minimum liquid surface temperatures, P_{VX} and P_{VN} , respectively, are calculated by substituting the corresponding temperatures, T_{LX} and T_{LN} , into Equation 1-27 or 1-28 after converting the temperatures to the units indicated for the respective equation. If T_{LX} and T_{LN} are unknown, Figure 7.1-17 can be used to calculate their values. In the case of a fully insulated tank maintained at constant temperature, the average daily vapor pressure range, ΔP_V , should be taken as zero.

If the liquid stored in the fixed roof tank has a true vapor pressure less than 0.1 psia and the tank breather vent settings are not greater than ± 0.03 psig, Equation 1-12 or Equation 1-13 may be used with an acceptable loss in accuracy.

If the tank location and tank color and condition are known, K_E may be calculated using the following equation in lieu of Equation 1-5:

$$K_E = 0.0018 \Delta T_V = 0.0018 [0.7 (T_{AX} - T_{AN}) + 0.02 \alpha I] \quad (1-12)$$

where:

K_E = vapor space expansion factor, per day

ΔT_V = average daily vapor temperature range, °R

T_{AX} = average daily maximum ambient temperature, °R

T_{AN} = average daily minimum ambient temperature, °R

α = tank surface solar absorptance, dimensionless

I = average daily total insolation on a horizontal surface, Btu/(ft² day)

- 0.0018 = constant, ($^{\circ}\text{R}$)⁻¹
- 0.7 = constant, dimensionless
- 0.02 = constant, ($^{\circ}\text{R ft}^2 \text{ day}$)/Btu

Average daily maximum and minimum ambient temperatures and average daily total insolation can be determined from historical meteorological data for the location or may be obtained from historical meteorological data for a nearby location. Historical meteorological data for selected locations are given in Table 7.1-7, where values of T_{AX} and T_{AN} are given in degrees Fahrenheit. These values are converted to degrees Rankine by adding 459.67.

If the tank location is unknown, a value of K_E can be calculated using typical meteorological conditions for the lower 48 states. The typical value for daily insolation is 1,370 Btu/(ft² day), the average daily range of ambient temperature is 21 $^{\circ}\text{R}$, and the tank surface solar absorptance is 0.25 for white paint in average condition. Substituting these values into Equation 1-12 results in a value of 0.04, as shown in Equation 1-13.

$$K_E = 0.04 \quad (1-13)$$

Diameter

For vertical tanks, the diameter is straightforward. If a user needs to estimate emissions from a horizontal fixed roof tank, some of the tank parameters can be modified before using the vertical tank emission estimating equations. First, by assuming that the tank is one-half filled, the surface area of the liquid in the tank is approximately equal to the length of the tank times the diameter of the tank. Next, assume that this area represents a circle, i.e., that the liquid is an upright cylinder. Therefore, the effective diameter, D_{Eh} , is then equal to:

$$D_{\text{Eh}} = \sqrt{\frac{L D}{\frac{\pi}{4}}} \quad (1-14)$$

where:

- D_{Eh} = effective tank diameter of the horizontal tank, ft
- L = length of the horizontal tank, ft (for tanks with rounded ends, use the overall length)
- D = diameter of a vertical cross-section of the horizontal tank, ft

By assuming the volume of the horizontal tank to be approximately equal to the cross-sectional area of the tank times the length of the tank, an effective height, H_{Eh} , of an equivalent upright cylinder may be calculated as:

$$H_{\text{Eh}} = \frac{\pi}{4} D \quad (1-15)$$

where:

- H_{Eh} = effective height of the horizontal tank, ft
- D = diameter of a vertical cross-section of the horizontal tank, ft

D_{Eh} should be used in place of D in Equation 1-4 for calculating the standing loss (or in Equation 1-3, if calculating the tank vapor space volume). One-half of the effective height, H_E , should be used as the vapor space outage, H_{VO} , in these equations. This method yields only a very approximate value for emissions from horizontal storage tanks. For underground horizontal tanks, assume that no breathing or standing losses occur ($L_S = 0$) because the insulating nature of the earth limits the diurnal temperature change. No modifications to the working loss equation are necessary for either aboveground or underground horizontal tanks. However, standing losses from underground gasoline tanks, which can experience relatively fast vapor growth after the ingestion of air and dilution of the headspace, are addressed in Section 5.2 of AP-42.

For rectangular tanks, effective diameter is calculated as:

$$D_{Er} = \sqrt{\frac{L_1 L_2}{\frac{\pi}{4}}} \quad (1-16)$$

where:

D_{Er} = effective tank diameter for a rectangular tank, ft

L_1 = length of side 1 of rectangular tank, ft

L_2 = length of side 2 of rectangular tank, ft

For square tanks, effective diameter is calculated as:

$$D_{Es} = \sqrt{\frac{L^2}{\frac{\pi}{4}}} \quad (1-17)$$

where:

D_{Es} = effective tank diameter for a square tank, ft

L = length of side of square tank, ft

D_{Er} or D_{Es} should be used in place of D in Equation 1-4 for calculating the standing loss (or in Equation 1-3, if calculating the tank vapor space volume) from rectangular or square tanks, respectively.

Vapor Space Outage

The vapor space outage, H_{VO} is the height of a cylinder of tank diameter, D , whose volume is equivalent to the vapor space volume of a fixed roof tank, including the volume under the cone or dome roof. The vapor space outage, H_{VO} , is estimated from:

$$H_{VO} = H_S - H_L + H_{RO} \quad (1-18)$$

where:

H_{VO} = vapor space outage, ft; use $H_{Eh}/2$ from Equation 1-15 for horizontal tanks

H_S = tank shell height, ft

H_L = liquid height, ft; typically assumed to be at the half-full level, unless known to be maintained at some other level

H_{RO} = roof outage, ft; see Note 1 to Equation 1-18 for a cone roof, Note 2 to Equation 1-18 for a dome roof, or Note 3 to Equation 1-18 for a flat roof

Notes on Equation 1-18:

Note 1 to Equation 1-18. For a cone roof, the roof outage, H_{RO} , is calculated as follows:

$$H_{RO} = (1/3) H_R \quad (1-19)$$

where:

H_{RO} = roof outage (or shell height equivalent to the volume contained under the roof), ft

H_R = tank roof height, ft

$$H_R = S_R R_S \quad (1-20)$$

where:

S_R = tank cone roof slope, ft/ft; if unknown, a standard value of 0.0625 is used

R_S = tank shell radius, ft

Note 2 to Equation 1-18. For a dome roof, the roof outage, H_{RO} , is calculated as follows:

$$H_{RO} = H_R \left[\frac{1}{2} + \frac{1}{6} \left[\frac{H_R}{R_S} \right]^2 \right] \quad (1-21)$$

where:

H_{RO} = roof outage, ft

R_S = tank shell radius, ft

H_R = tank roof height, ft

$$H_R = R_R - (R_R^2 - R_S^2)^{0.5} \quad (1-22)$$

where:

H_R = tank roof height, ft

R_R = tank dome roof radius, ft

R_S = tank shell radius, ft

The value of R_R usually ranges from 0.8D - 1.2D, where $D = 2 R_S$. If R_R is unknown, the tank diameter is used in its place. If the tank diameter is used as the value for R_R , Equations 1-21 and 1-22 reduce to

$H_{RO} = 0.137 R_S$ and $H_R = 0.268 R_S$.

Note 3 to Equation 1-18. For a flat roof, the roof outage, H_{RO} is calculated using Equation 1-19 and Equation 1-20, except S_R = tank flat roof slope, ft/ft = 0. Therefore, H_{RO} equals zero.

Vented Vapor Saturation Factor

The vented vapor saturation factor, K_S , is calculated using the following equation:

$$K_S = \frac{1}{1 + 0.053 P_{VA} H_{VO}} \quad (1-23)$$

where:

- K_S = vented vapor saturation factor, dimensionless
- P_{VA} = vapor pressure at average daily liquid surface temperature, psia; see Note 1 to Equation 1-24 and Note 2 to Equation 1-24
- H_{VO} = vapor space outage, ft, see Equation 1-18
- 0.053 = constant, (psia-ft)⁻¹

Stock Vapor Density, W_V - The density of the vapor is calculated using the following equation:

$$W_V = \frac{M_V P_{VA}}{R T_V} \quad (1-24)$$

where:

- W_V = vapor density, lb/ft³
- M_V = vapor molecular weight, lb/lb-mole; see Note 1 to Equation 1-24
- R = the ideal gas constant, 10.731 psia ft³/lb-mole °R
- P_{VA} = vapor pressure at average daily liquid surface temperature, psia; see Note 1 to Equation 1-24 and Note 2 to Equation 1-24
- T_V = average vapor temperature, °R; see Note 6 to Equation 1-24

Notes on Equation 1-24:

Note 1 to Equation 1-24. The molecular weight of the vapor, M_V , can be determined from Table 7.1-2 and 7.1-3 for selected petroleum liquids and selected organic chemicals, respectively, or by analyzing vapor samples. Where mixtures of organic liquids are stored in a tank, M_V can be calculated from the liquid composition. The molecular weight of the vapor, M_V , is equal to the sum of the molecular weight, M_i , multiplied by the vapor mole fraction, y_i , for each component. The vapor mole fraction is equal to the partial pressure of component I divided by the total vapor pressure. The partial pressure of component I is equal to the true vapor pressure of component I (P) multiplied by the liquid mole fraction, (x_i). Therefore,

$$M_V = \sum M_i y_i = \sum M_i \left(\frac{P x_i}{P_{VA}} \right) \quad (1-25)$$

where:

P_{VA} , total vapor pressure of the stored liquid, by Raoult's Law³⁰, is:

$$P_{VA} = \sum P x_i \quad (1-26)$$

where:

P_{VA} = total vapor pressure of the stored liquid, psia

P = vapor pressure of pure component i at the average daily liquid surface temperature, psia

x_i = liquid mole fraction, lb-mole/lb-mole

For more detailed information on Raoult's Law, please refer to Section 7.1.4. Frequently, 'however, the vapor pressure is not known for each component in a mixture. For more guidance on determining the total vapor pressure at a given temperature (*i.e.*, the true vapor pressure), see Note 2 to Equation 1-24 below.

Note 2 to Equation 1-24. True vapor pressure is defined in various ways for different purposes within the industry, such as "bubble point" for transportation specifications, but for purposes of these emissions estimating methodologies it is the sum of the equilibrium partial pressures exerted by the components of a volatile organic liquid, as shown in Equation 1-26. True vapor pressure may be determined by ASTM D2879 (or ASTM D6377 for crude oils with a true vapor pressure greater than 3.6 psia or ASTM D6378 for petroleum products with a true vapor pressure greater than 1.0 psia) or obtained from standard reference texts. For certain petroleum liquids, true vapor pressure may be predicted from Reid vapor pressure, which is the absolute vapor pressure of volatile crude oil and volatile non-viscous petroleum liquids, as determined by ASTM D323. ASTM D 5191 may be used as an alternative method for determining Reid vapor pressure for petroleum products, however, it should not be used for crude oils.

Caution should be exercised when considering ASTM D2879 for determining the true vapor pressure of certain types of mixtures. Vapor pressure is sensitive to the lightest components in a mixture, and the de-gassing step in ASTM D2879 can remove lighter fractions from mixtures such as No. 6 fuel oil if it is not done with care (*i.e.* at an appropriately low pressure and temperature). In addition, any dewatering of a sample prior to measuring its vapor pressure must be done using a technique that has been demonstrated to not remove the lightest organic compounds in the mixture. Alternatives to the method may be developed after publication of this chapter.

True vapor pressure can be determined for crude oils from Reid vapor pressure using Figures 7.1-13a and 7.1-13b. However, the nomograph in Figure 7.1-13a and the correlation equation in Figure 7.1-13b for crude oil are known to have an upward bias, and thus use of ASTM D6377 is more accurate for crude oils with a true vapor pressure greater than 3.6 psia. ASTM D6377 may be used to directly measure true vapor pressure at a given temperature. In order to utilize ASTM D6377 to predict true vapor pressure values over a range of temperatures, the method should be applied at multiple temperatures. A regression of the log-transformed temperature versus vapor pressure data thus

obtained may be performed to obtain A and B constants for use in Equation 1-27. In order to determine true vapor pressure for purposes of estimating emissions of volatile organic compounds, ASTM D6377 should be performed using a vapor-to-liquid ratio of 4:1, which is expressed in the method as VPCR₄.

For light refined stocks (gasolines and naphthas) for which the Reid vapor pressure and distillation slope are known, Figures 7.1-14a and 7.1-14b can be used. For refined stocks with Reid vapor pressure below the 1 psi applicability limit of Figures 7.1-14a and 7.1-14b, true vapor pressure can be determined using ASTM D2879. In order to use Figures 7.1-13a, 7.1-13b, 7.1-14a, or 7.1-14b, the stored liquid surface temperature, T_{LA}, must be determined in degrees Fahrenheit. See Note 3 to Equation 1-24 to determine T_{LA}.

Alternatively, true vapor pressure for selected petroleum liquid stocks, at the stored liquid surface temperature, can be determined using the following equation:

$$P_{VA} = \exp \left[A - \left(\frac{B}{T_{LA}} \right) \right] \quad (1-27)$$

where:

exp = exponential function

A = constant in the vapor pressure equation, dimensionless

B = constant in the vapor pressure equation, °R

T_{LA} = average daily liquid surface temperature, °R; see Note 3 to Equation 1-24

P_{VA} = true vapor pressure, psia

For selected petroleum liquid stocks, physical property data including vapor pressure constants A and B for use in Equation 1-27 are presented in Table 7.1-2. For refined petroleum stocks with Reid vapor pressure within the limits specified in the scope of ASTM D 323, the constants A and B can be calculated from the equations presented in Figure 7.1-15 and the distillation slopes presented in Table 7.1-2. For crude oil stocks, the constants A and B can be calculated from Reid vapor pressure using the equations presented in Figure 7.1-16. However, the equations in Figure 7.1-16 are known to have an upward bias²⁹, and thus use of ASTM D 6377 is more accurate. Note that in Equation 1-27, T_{LA} is determined in degrees Rankine instead of degrees Fahrenheit.

The true vapor pressure of organic liquids at the stored liquid temperature can also be estimated by Antoine's equation:

$$\log P_{VA} = A - \left(\frac{B}{T_{LA} + C} \right) \quad (1-28)$$

where:

log = log 10

A = constant in vapor pressure equation, dimensionless

- B = constant in vapor pressure equation, °C
- C = constant in vapor pressure equation, °C
- T_{LA} = average daily liquid surface temperature, °C
- P_{VA} = vapor pressure at average daily liquid surface temperature, mm Hg

For selected pure chemicals, the values for the constants A, B, and C are listed in Table 7.1-3. Note that in Equation 1-28, T_{LA} is determined in degrees Celsius instead of degrees Rankine. Also, in Equation 1-28, P_{VA} is determined in mm of Hg rather than psia (760 mm Hg = 14.7 psia).

More rigorous thermodynamic equations of state are available in process simulation software packages. The use of such programs may be preferable in determining the true vapor pressure of mixtures that are not adequately characterized by Raoult's Law.

Note 3 to Equation 1-24. The average daily liquid surface temperature, T_{LA}, refers to the liquid surface temperature averaged over all of the days in the given period of time, such as one year, and should not be construed as being applicable to an individual day. While the accepted methodology is to use the average temperature, this approach introduces a bias in that the true vapor pressure, P_{VA}, is a non-linear function of temperature. However, the greater accuracy that would be achieved by accounting for this logarithmic function is not warranted, given the associated computational burden. The average daily liquid surface temperature is calculated for an uninsulated fixed roof tank using Equation 1-29.

$$T_{LA} = \left(0.5 - \frac{0.8}{4.4(H_S/D) + 3.8} \right) T_{AA} + \left(0.5 + \frac{0.8}{4.4(H_S/D) + 3.8} \right) T_B + \frac{0.021 \alpha_R I + 0.013(H_S/D) \alpha_S I}{4.4(H_S/D) + 3.8} \quad (1-29)$$

where:

- T_{LA} = average daily liquid surface temperature, °R
- H_S = tank shell height, ft
- D = tank diameter, ft,
- T_{AA} = average daily ambient temperature, °R; see Note 4 to Equation 1-24
- T_B = liquid bulk temperature, °R; see Note 5 to Equation 1-24
- α_R = tank roof surface solar absorptance, dimensionless; see Table 7.1-6
- α_S = tank shell surface solar absorptance, dimensionless; see Table 7.1-6
- I = average daily total insolation factor, Btu/(ft² day); see Table 7.1-7

API assigns a default value of H_S/D = 0.5 and an assumption of α_R = α_S, resulting in the simplified equation shown below for an uninsulated fixed roof tank:²²

$$T_{LA} = 0.4T_{AA} + 0.6T_B + 0.005 \alpha I \quad (1-30)$$

where:

- α = average tank surface solar absorptance, dimensionless

Equation 1-29 and Equation 1-30 should not be used to estimate liquid surface temperature for insulated tanks. In the case of fully insulated tanks, the average liquid surface temperature should be assumed to equal the average liquid bulk temperature (see Note 5 to Equation 1-24). For purposes of estimating emissions, a storage tank should be deemed insulated only if the roof and shell are both fully insulated so as to minimize heat exchange with ambient air. If only the shell is insulated, and not the roof, there likely will be sufficient heat exchange through the roof such that Equation 1-30 would be applicable.

A more accurate method of estimating the average liquid surface temperature, T_{LA} , in partially insulated fixed roof tanks is given below. When the tank shell is insulated but the tank roof is not, heat gain to the tank from insolation is almost entirely through the tank roof and thus the liquid surface temperature is not sensitive to H_s/D .

$$T_{LA} = 0.3 T_{AA} + 0.7 T_B + 0.005 \alpha_R I \quad (1-31)$$

If T_{LA} is used to calculate P_{VA} from Figures 7.1-13a, 7.1-13b, 7.1-14a, or 7.1-14b, T_{LA} must be converted from degrees Rankine to degrees Fahrenheit ($^{\circ}F = ^{\circ}R - 459.67$). If T_{LA} is used to calculate P_{VA} from Equation 1-28, T_{LA} must be converted from degrees Rankine to degrees Celsius ($^{\circ}C = [^{\circ}R - 491.67]/1.8$).

Note 4 to Equation 1-24. The average daily ambient temperature, T_{AA} , is calculated using the following equation:

$$T_{AA} = \left(\frac{T_{AX} + T_{AN}}{2} \right) \quad (1-32)$$

where:

- T_{AA} = average daily ambient temperature, $^{\circ}R$
- T_{AX} = average daily maximum ambient temperature, $^{\circ}R$
- T_{AN} = average daily minimum ambient temperature, $^{\circ}R$

Table 7.1-7 gives historical values of T_{AX} and T_{AN} in degrees Fahrenheit for selected U.S. cities. These values are converted to degrees Rankine by adding 459.67.

Note 5 to Equation 1-24. The liquid bulk temperature, T_B , should preferably be based on measurements or estimated from process knowledge. For uninsulated fixed roof tanks known to be in approximate equilibrium with ambient air, heat gain to the bulk liquid from insolation is almost entirely through the tank shell; thus the liquid bulk temperature is not sensitive to H_s/D and may be calculated using the following equation:

$$T_B = T_{AA} + 0.003 \alpha_S I \quad (1-33)$$

where:

- T_B = liquid bulk temperature, $^{\circ}R$

T_{AA} = average daily ambient temperature, °R, as calculated in Note 4 to Equation 1-24

α_S = tank shell surface solar absorptance, dimensionless; see Table 7.1-6

I = average daily total insolation factor, Btu/(ft² day); see Table 7.1-7.

Note 6 to Equation 1-24. The average vapor temperature, T_V , for an uninsulated tank may be calculated using the following equation:

$$T_V = \frac{[2.2 (H_S/D) + 1.1] T_{AA} + 0.8 T_B + 0.021 \alpha_R I + 0.013 (H_S/D) \alpha_S I}{2.2 (H_S/D) + 1.9} \quad (1-34)$$

where:

H_S = tank shell height, ft

D = tank diameter, ft,

T_{AA} = average daily ambient temperature, °R

T_B = liquid bulk temperature, °R

α_R = tank roof surface solar absorptance, dimensionless

α_S = tank shell surface solar absorptance, dimensionless

I = average daily total insolation factor, Btu/(ft² day).

API assigns a default value of $H_S/D = 0.5$ and an assumption of $\alpha_R = \alpha_S$, resulting in the simplified equation shown below for an uninsulated tank:²²

$$T_V = 0.7 T_{AA} + 0.3 T_B + 0.009 \alpha I \quad (1-35)$$

where:

α = average tank surface solar absorptance, dimensionless

When the shell is insulated, but not the roof, the temperature equations are independent of H_S/D .

$$T_V = 0.6 T_{AA} + 0.4 T_B + 0.01 \alpha_R I \quad (1-36)$$

When the tank shell and roof are fully insulated, the temperatures of the vapor space and the liquid surface are taken as equal to the temperature of the bulk liquid.

7.1.3.1.2 Working Loss

The fixed roof tank working loss, L_W , refers to the loss of stock vapors as a result of tank filling operations. Fixed roof tank working losses can be estimated from:

$$L_W = V_Q K_N K_P W_V K_B \quad (1-37)$$

where:

L_W = working loss, lb/yr

V_Q = net working loss throughput, ft^3/yr , see Note 1 to Equation 1-37

K_N = working loss turnover (saturation) factor, dimensionless

for turnovers > 36 , $K_N = (180 + N)/6N$

for turnovers ≤ 36 , $K_N = 1$

for tanks that are vapor balanced and tanks in which flashing occurs, $K_N = 1$ regardless of the number of turnovers; further adjustment of K_N may be appropriate in the case of splash loading into a tank.

N = number of turnovers per year, dimensionless:

$$N = \Sigma H_{QI} / (H_{LX} - H_{LN}) \quad (1-38)$$

ΣH_{QI} = the annual sum of the increases in liquid level, ft/yr

If ΣH_{QI} is unknown, it can be estimated from pump utilization records. Over the course of a year, the sum of increases in liquid level, ΣH_{QI} , and the sum of decreases in liquid level, ΣH_{QD} , will be approximately the same. Alternatively, ΣH_{QI} may be approximated as follows:

$$\Sigma H_{QI} = (5.614 Q) / ((\pi/4) D^2) \quad (1-39)$$

5.614 = the conversion of barrels to cubic feet, ft^3/bbl

Q = annual net throughput, bbl/yr [Note that 1 bbl = 42 gallons]

For horizontal tanks, use D_{Eh} (Equation 1-14) in place of D in Equation 1-39

For rectangular tanks, use D_{Er} (Equation 1-16) in place of D in Equation 1-39

For square tanks, use D_{Es} (Equation 1-17) in place of D in Equation 1-39

H_{LX} = maximum liquid height, ft

If the maximum liquid height is unknown, for vertical tanks use one foot less than the shell height and for horizontal tanks use $(\pi/4) D$ where D is the diameter of a vertical cross-section of the horizontal tank

H_{LN} = minimum liquid height, ft

If the minimum liquid height is unknown, for vertical tanks use 1 and for horizontal tanks use 0

K_p = working loss product factor, dimensionless

for crude oils, $K_p = 0.75$;

adjustment of K_p may be appropriate in the case of splash loading into a tank;

for all other organic liquids, $K_p = 1$

V_v = vapor density, lb/ft^3 , see Equation 1-24

K_B = vent setting correction factor, dimensionless, see Note 2 to Equation 1-37 for open vents and for a vent setting range up to ± 0.03 psig, $K_B = 1$

Notes on Equation 1-37:

Note 1 to Equation 1-37. Net Working Loss Throughput.

The net working loss throughput, V_Q , is the volume associated with increases in the liquid level, and is calculated as follows:

$$V_Q = (\Sigma H_{QI})(\pi/4) D^2 \quad (1-40)$$

where:

ΣH_{QI} = the annual sum of the increases in liquid level, ft/yr

D_{EH} should be used for horizontal tanks in place of D in Equation 1-40. See Equation 1-14.

D_{ER} should be used for rectangular tanks in place of D in Equation 1-40. See Equation 1-16.

D_{ES} should be used for square tanks in place of D in Equation 1-40. See Equation 1-17.

If ΣH_{QI} is unknown, ΣH_{QI} can be estimated from pump utilization records. Over the course of a year, the sum of increases in liquid level, ΣH_{QI} , and the sum of decreases in liquid level, ΣH_{QD} , will be approximately the same. Alternatively, V_Q may be approximated as follows:

$$V_Q = 5.614 Q \quad (1-41)$$

where:

5.614 = the conversion of barrels to cubic feet, ft³/bbl

Q = annual net throughput, bbl/yr

Note: Use of gross throughput to approximate the sum of increases in liquid level will significantly overstate emissions if pumping in and pumping out take place at the same time. However, use of gross throughput is still allowed, since it is clearly a conservative estimate of emissions.

Note 2 to Equation 1-37. Vent Setting Correction Factor

When the breather vent settings are greater than the typical values of ± 0.03 psig, and the condition expressed in Equation 1-42 is met, a vent setting correction factor, K_B , must be determined using Equation 1-42. This value of K_B will be used in Equation 1-37 to calculate working losses.

When:

$$K_N \left[\frac{P_{BP} + P_A}{P_I + P_A} \right] > 1.0 \quad (1-42)$$

Then:

$$K_B = \left[\frac{\frac{P_I + P_A}{K_N} - P_{VA}}{P_{BP} + P_A - P_{VA}} \right] \quad (1-43)$$

where:

K_B = vent setting correction factor, dimensionless

P_I = pressure of the vapor space at normal operating conditions, psig

P_I is an actual pressure reading (the gauge pressure). If the tank is held at atmospheric pressure (not held under a vacuum or at a steady pressure) P_I would be 0.

P_A = atmospheric pressure, psia

K_N = working loss turnover (saturation) factor (dimensionless), see Equation 1-37

P_{VA} = vapor pressure at the average daily liquid surface temperature, psia; see Note 1 to Equation 1-24 and Note 2 to Equation 1-24

P_{BP} = breather vent pressure setting, psig.

See Section 7.1.6.2 for a more approximate equation for fixed roof tank working loss that was used historically, but which is no longer recommended.

7.1.3.2 Routine Losses From Floating Roof Tanks^{3-5,13-17}

Routine floating roof tank emissions are the sum of standing and working losses. Routine losses from floating roof tanks may be written as:

$$L_T = L_S + L_W \quad (2-1)$$

where:

L_T = total routine loss, lb/yr

L_S = standing loss, lb/yr; see Equation 2-2

L_W = working (withdrawal) loss, lb/yr; see Equation 2-19

The equations presented in this subsection apply only to floating roof tanks. The equations are not intended to be used in the following applications:

1. To estimate losses from unstable or boiling stocks (see Section 7.1.3.5) or from mixtures of hydrocarbons or petrochemicals for which the vapor pressure is not known or cannot readily be predicted;
2. To estimate losses from floating roof tanks vented only through a pressure/vacuum vent in the fixed roof (*i.e.*, no open vents) (see Section 7.1.3.8.2);
3. To estimate losses from tanks in which the materials used in the rim seal and/or deck fittings are either deteriorated or significantly permeated by the stored liquid;
4. To estimate losses that result from the landing of a floating roof (see Section 7.1.3.3); or
5. To estimate losses that result from cleaning a tank (see Section 7.1.3.4).

7.1.3.2.1 Standing Loss

Standing losses from floating roof tanks are the sum of rim seal, deck fitting and deck seam losses, and may be written as:

$$L_S = L_R + L_F + L_D \quad (2-2)$$

where:

L_S = standing loss, lb/yr

L_R = rim seal loss, lb/yr; see Equation 2-3

L_F = deck fitting loss, lb/yr; see Equation 2-13

L_D = deck seam loss (internal floating roof tanks only), lb/yr; see Equation 2-18

Rim Seal Loss - Rim seal loss from floating roof tanks can be estimated using the following equation:

$$L_R = (K_{Ra} + K_{Rb} v^n) DP^* M_V K_C \quad (2-3)$$

where:

L_R = rim seal loss, lb/yr

K_{Ra} = zero wind speed rim seal loss factor, lb-mole/ft•yr; see Table 7.1-8

K_{Rb} = wind speed dependent rim seal loss factor, lb-mole/(mph)ⁿft•yr; see Table 7.1-8

v = average ambient wind speed at tank site, mph; see Note 1

n = seal-related wind speed exponent, dimensionless; see Table 7.1-8

P^* = vapor pressure function, dimensionless; see Note 2

$$P^* = \frac{\frac{P_{VA}}{P_A}}{\left(1 + \left[1 - \left(\frac{P_{VA}}{P_A}\right)\right]^{0.5}\right)^2} \quad (2-4)$$

where:

P_{VA} = vapor pressure at average daily liquid surface temperature, psia; See Note 3 below and Note 1 to Equation 1-24 and Note 2 to Equation 1-24

P_A = atmospheric pressure, psia

D = tank diameter, ft

M_V = average vapor molecular weight, lb/lb-mole; see Note 1 to Equation 1-24,

K_C = product factor ($K_C = 0.4$ for crude oils and $K_C = 1$ for all other organic liquids).

Notes on Equation 2-4.

Note 1. If the ambient wind speed at the tank site is not available, use wind speed data from the nearest local weather station or values from Table 7.1-7. Ambient wind speed should be measured at an elevation of at least 10 meters above grade. If the tank is an internal or domed external floating roof tank, the value of v is zero.

Note 2. P^* can be calculated or read directly from Figure 7.1-19.

Note 3. The average daily liquid surface temperature, T_{LA} , for calculation of vapor pressure, P_{VA} , for floating roof tanks shall be determined as follows:

For internal and domed external floating roof tanks:

$$T_{LA} = \frac{[2.86 (H_S/D) + 1.43] T_{AA} + [3.52 (H_S/D) + 3.79] T_B + 0.027 \alpha_R I + 0.017 (H_S/D) \alpha_S I}{6.38 (H_S/D) + 5.22} \quad (2-5)$$

where:

- T_{LA} = average daily liquid surface temperature, °R
- H_S = tank shell height, ft
- D = tank diameter, ft,
- T_{AA} = average daily ambient temperature, °R; see Equation 1-32
- T_B = liquid bulk temperature, °R;
- α_R = tank roof surface solar absorptance, dimensionless; see Table 7.1-6
- α_S = tank shell surface solar absorptance, dimensionless; see Table 7.1-6
- I = average daily total insolation factor, Btu/(ft² day); see Table 7.1-7

API assigns a default value of $H_S/D = 0.5$ and an assumption of $\alpha_R = \alpha_S$, resulting in the simplified equation shown below for an uninsulated internal or domed external floating roof tank:²²

$$T_{LA} = 0.3 T_{AA} + 0.7 T_B + 0.004 \alpha I \quad (2-6)$$

where:

- α = average tank surface solar absorptance, dimensionless

The average daily liquid surface temperature, T_{LA} , for external floating roof tanks is independent of H_S/D for a given value of T_B . Different expressions for T_{LA} are given for the two common types of external floating roof deck. If the type of external floating roof deck is unknown, assume the deck to be the steel peripheral pontoon type.

For external floating roof tanks with a steel peripheral pontoon deck (single deck center area):

$$T_{LA} = 0.7 T_{AA} + 0.3 T_B + 0.008 \alpha_R I \quad (2-7)$$

where the liquid bulk temperature, T_B , is preferably determined from measurements or estimated from process knowledge, but otherwise may be estimated as follows:

$$T_B = T_{AA} + [0.71 \alpha_R I + 0.485 (H_S/D) \alpha_S I] / (170 H_S/D + 57) \quad (2-8)$$

For default $H_S/D = 0.5$, when $\alpha_R = \alpha_S$:

$$T_B = T_{AA} + 0.007 \alpha I \quad (2-9)$$

For external floating roof tanks with a steel double deck:

$$T_{LA} = 0.3 T_{AA} + 0.7 T_B + 0.009 \alpha_R I \quad (2-10)$$

where the liquid bulk temperature, T_B , is preferably determined from measurements or estimated from process knowledge, but otherwise may be estimated as follows:

$$T_B = T_{AA} + [0.39 \alpha_R I + 0.485 (H_s/D) \alpha_S I] / (170 H_s/D + 45) \quad (2-11)$$

For default $H_s/D = 0.5$, when $\alpha_R = \alpha_S$:

$$T_B = T_{AA} + 0.005 \alpha I \quad (2-12)$$

Deck Fitting Loss - Deck fitting losses from floating roof tanks can be estimated by the following equation:

$$L_F = F_F P^* M_V K_C \quad (2-13)$$

where:

L_F = the deck fitting loss, lb/yr

F_F = total deck fitting loss factor, lb-mole/yr

$$F_F = [(N_{F_1} K_{F_1}) + (N_{F_2} K_{F_2}) + \dots + (N_{F_{n_f}} K_{F_{n_f}})] \quad (2-14)$$

where:

N_{F_i} = number of deck fittings of a particular type ($i = 0, 1, 2, \dots, n_f$), dimensionless

K_{F_i} = deck fitting loss factor for a particular type fitting, lb-mole/yr;

($i = 0, 1, 2, \dots, n_f$) see Equation 2-15

n_f = total number of different types of fittings, dimensionless

P^* , M_V , K_C are as defined for Equation 2-3.

The value of F_F may be calculated by using actual tank-specific data for the number of each fitting type (N_F) and then multiplying by the fitting loss factor for each fitting (K_F).

The deck fitting loss factor, K_{F_i} for a particular type of fitting, can be estimated by the following equation:

$$K_{F_i} = K_{F_{a_i}} + K_{F_{b_i}} (K_v v)^{m_i} \quad (2-15)$$

where:

K_{F_i} = loss factor for a particular type of deck fitting, lb-mole/yr

$K_{F_{a_i}}$ = zero wind speed loss factor for a particular type of fitting, lb-mole/yr

$K_{F_{b_i}}$ = wind speed dependent loss factor for a particular type of fitting, lb-mole/(mph) ^{m_i} •yr

m_i = loss factor for a particular type of deck fitting, dimensionless

$i = 1, 2, \dots, n$, dimensionless

- n = number of deck fittings
- K_v = fitting wind speed correction factor, dimensionless; see below
- v = average ambient wind speed, mph

For external floating roof tanks, the fitting wind speed correction factor, K_v , is equal to 0.7. For internal and domed external floating roof tanks, the value of v in Equation 2-15 is zero and the equation becomes:

$$K_{Fi} = K_{Fai} \quad (2-16)$$

Loss factors K_{Fa} , K_{Fb} , and m are provided in Table 7.1-12 for the most common deck fittings used on floating roof tanks. These factors apply only to typical deck fitting conditions and when the average ambient wind speed is below 15 miles per hour. Typical numbers of deck fittings for floating roof tanks are presented in Tables 7.1-11, 7.1-12, 7.1-13, 7.1-14, and 7.1-15.

Loss factors may be estimated for deck fitting configurations that are not listed in Table 7.1-12, at the zero miles-per-hour wind speed condition (IFRTs and Domed EFRTs), from the following equation:

$$K_{Fai} = 0.27(A_{fi})^{0.86} \quad (2-17)$$

Where:

- K_{Fai} = zero-wind-speed loss factor for a particular type of deck fitting, in pound-moles per year.
- A_{fi} = liquid surface area within a particular type of deck fitting, in square inches. The liquid surface area is the area inside the deck fitting well or leg sleeve, less any area occupied by an obstruction in the deck fitting well or leg sleeve (such as a fixed-roof support column, unslotted guidepole, guidepole float, or deck support leg).
- i = 1, 2, ..., n, dimensionless
- n = number of deck fittings

The coefficient, 0.27, has units of pound-moles per (square inches)^{0.86}-year, and the exponent, 0.86, is dimensionless.

This equation is only applicable when the distance from the liquid surface to the top of the deck fitting well or leg sleeve is 12 inches or greater. Shorter deck fitting wells or leg sleeves may result in higher loss rates. There are no similar algorithms available for estimating loss factors for shorter deck fitting wells or leg sleeves.

This equation is for an uncontrolled deck fitting. Effective deck fitting controls would be expected to result in lower loss factors than would be estimated by this equation, but there are no algorithms available for estimating the effectiveness of deck fitting controls.

This equation is for the zero miles-per-hour wind speed condition. There are no algorithms available for estimating loss factors at non-zero wind speeds (EFRTs).

Deck Seam Loss – Deck seams that are welded are assumed to have no deck seam loss (i.e., $L_D = 0$). All external floating roofs are assumed to be of welded construction, and some internal floating roofs

are of welded construction. Internal floating roof tanks with bolted decks may have deck seam losses. Deck seam loss can be estimated by the following equation:

$$L_D = K_D S_D D^2 P^* M_V K_C \quad (2-18)$$

where:

$$\begin{aligned} K_D &= \text{deck seam loss per unit seam length factor, lb-mole/ft-yr} \\ &= 0.0 \text{ for welded deck} \\ &= 0.14 \text{ for bolted deck; see Note} \\ S_D &= \text{deck seam length factor, ft/ft}^2 \\ &= \frac{L_{seam}}{A_{deck}} \end{aligned}$$

where: L_{seam} = total length of deck seams, ft

$$A_{deck} = \text{area of deck, ft}^2 = \frac{\pi \cdot D^2}{4}$$

D , P^* , M_V , and K_C are as defined for Equation 2-3.

If the total length of the deck seam is not known, Table 7.1-16 can be used to determine S_D . For a deck constructed from continuous metal sheets with a 7-ft spacing between the seams, a value of 0.14 ft/ft² can be used. A value of 0.33 ft/ft² can be used for S_D when a deck is constructed from rectangular panels 5 ft by 7.5 ft. Where tank-specific data concerning width of deck sheets or size of deck panels are unavailable, a default value for S_D can be assigned. A value of 0.20 ft/ft² can be assumed to represent the most common bolted decks currently in use.

Note: Recently vendors of bolted decks have been using various techniques, such as gasketing the deck seams, in an effort to reduce deck seam losses. However, emission factors are not currently available in AP-42 that represent the emission reduction, if any, achieved by these techniques. Some vendors have developed specific factors for their deck designs; however, use of these factors is not recommended until approval has been obtained from the governing regulatory agency or permitting authority. A weld seam does not have to be structural (*i.e.*, may be seal welded) to constitute a welded deck seam for purposes of estimating emissions, but a deck seam that is bolted or otherwise mechanically fastened and sealed with elastomeric materials or chemical adhesives is not a welded seam.

7.1.3.2.2 Working (withdrawal) Loss

The working loss from floating roof storage tanks, also known as withdrawal loss, can be estimated using Equation 2-19.

$$L_W = \frac{0.943 Q C_S W_L}{D} \left(1 + \frac{N_C F_C}{D} \right) \quad (2-19)$$

where:

- L_w = working (withdrawal) loss, lb/yr
- Q = annual net throughput, bbl/yr (1 bbl = 42 gallons); see Note 1
- C_s = shell clingage factor, bbl/1,000 ft²; see Table 7.1-10
- W_L = average organic liquid density, lb/gal; see Note 2
- D = tank diameter, ft
- 0.943 = constant, 1,000 ft³•gal/bbl²
- N_c = number of fixed roof support columns, dimensionless; see Note 3
- F_c = effective column diameter, ft (column perimeter [ft]/ π); see Note 4

Notes on Equation 2-19:

Note 1. For tanks in which liquid is pumped in and out at the same time, the use of gross throughput to estimate working loss would overstate emissions, but the overestimation would not be as significant as for the working loss of fixed roof tanks. It would be more appropriate to express Q in terms of the sum of the decreases in liquid level ΣH_{QD} . Over the course of a year, the sum of decreases in liquid level, ΣH_{QD} , and the sum of increases in liquid level, ΣH_{QI} , will be approximately the same. The effective annual throughput, Q , may be calculated in terms of ΣH_{QD} as follows:

$$Q = \frac{\pi}{4} D^2 \frac{\Sigma H_{QD}}{5.614} \quad (2-20)$$

- ΣH_{QD} = the annual sum of the decreases in liquid level, ft/yr
- D = tank diameter, ft
- 5.614 = the conversion of barrels to cubic feet, ft³/bbl

If ΣH_{QD} is unknown, Q can be taken as the annual net throughput.

Note 2. A listing of the average organic liquid density for select chemicals is provided in Tables 7.1-2 and 7.1-3. If W_L is not known for gasoline, an average value of 5.6 lb/gal can be assumed.

Note 3. For a self-supporting fixed roof or an external floating roof tank:

$$N_c = 0.$$

For a column-supported fixed roof:

$$N_c = \text{use tank-specific information or see Table 7.1-11.}$$

Note 4. Use tank-specific effective column diameter or

$$F_c = 1.1 \text{ for 9-inch by 7-inch built-up columns,}$$

$$F_c = 0.7 \text{ for 8-inch-diameter pipe columns, and}$$

$$F_c = 1.0 \text{ if column construction details are not known}$$

7.1.3.3 Floating Roof Landing Losses ²¹

When using floating roof tanks, the roof floats on the surface of the liquid inside the tank and reduces evaporative losses during routine operations. However, when the tank is emptied to the point that the roof lands on deck legs or hangers, there is a period where the roof is not floating and other mechanisms contribute to emissions. These emissions continue until the tank is refilled to a sufficient level to again float the roof. Therefore, these emission estimation calculations are applicable each time there is a landing of the floating roof.

This model does not directly address standing idle losses for partial days, but it would be reasonable to estimate the emissions for a partial day by estimating the standing idle emissions for a single day and then pro-rating that estimate by the number of hours that the floating roof was actually landed. For example, if the floating roof were landed for 6 hours, then the estimated standing idle losses would be 6/24, or one quarter, of the estimated daily standing idle losses.

The total loss from floating roof tanks during a roof landing is the sum of the standing idle losses and the filling losses. This relationship may be written in the form of an equation:

$$L_{TL} = L_{SI} + L_{FL} \quad (3-1)$$

where:

L_{TL} = total losses during roof landing, lb per landing episode

L_{SI} = standing idle losses during roof landing, lb per landing episode

L_{FL} = filling losses during roof landing, lb per landing episode

The group of applicable equations to estimate the landing losses differs according to the type of floating roof tank that is being used. The equations needed to estimate landing losses from internal or domed external floating roof tanks are contained in Table 7.1-17; equations for external floating roof tanks are contained in Table 7.1-18; and equations for drain-dry floating roof tanks are contained in Table 7.1-19. The following sections explain these equations in more detail.

7.1.3.3.1 Standing Idle Losses

After the floating roof is landed and the liquid level in the tank continues to drop, a vacuum is created which could cause the floating roof to collapse. To prevent damage and to equalize the pressure, a breather vent (vacuum breaker) is actuated. Then, a vapor space is formed between the floating roof and the liquid. The breather vent may remain open until the roof is again floated, so whenever the roof is landed, vapor can be lost through this vent as well as through other deck fittings and past the rim seal. Even in the case of a self-closing breather vent, the vapor space beneath the floating roof is vented via the other deck fittings and the rim seal, which is effectively rendered vapor mounted once the liquid level drops below the bottom of the rim seal. These losses are called “standing idle losses.”

The three different mechanisms that contribute to standing idle losses are (1) breathing losses from vapor space, (2) wind losses, and (3) clingage losses. The specific loss mechanism is dependent on the type of floating roof tank and the bottom condition.

For internal or domed external floating roof tanks with liquid remaining in the bottom (liquid heel), the breathing losses originate from a discernible level of liquid that remains in the tank. This is typically the case for internal or domed external floating roof tanks with nominally flat bottoms (including those built with a slight upward cone), due to the flatness of the tank bottom and the position of the withdrawal line. If the remaining liquid covers the entire bottom of the tank, this is known as a full liquid heel. The liquid evaporates into the vapor space beneath the landed floating roof and daily changes in ambient temperature cause this vapor space to breathe in a manner similar to a fixed roof

tank. A partial liquid heel may be left in tanks with sloped bottoms, if the withdrawal of liquid ceases while some free standing liquid remains in a sump or elsewhere in the bottom of the tank.

For external floating roof tanks, which are not fully shielded from the surrounding atmosphere, wind action across the landed floating roof can create pressure differentials that cause vapors to flow from beneath the floating roof. The higher the wind speeds, the more vapor that can be expelled. These are known as wind losses.

For tanks with a cone-down or shovel bottom, the floor of the tank is sloped to allow for more thorough emptying of the tank contents, therefore, the amount of liquid remaining may differ significantly from tanks with flat bottoms (see Figure 7.1-20). When the emptying operation drains the tank bottom but leaves a heel of liquid in or near the sump, the tank is considered to have a partial liquid heel. A drain-dry condition is attained only when all of the standing liquid has been removed, including from the bottom of the sump. However, due to sludge buildup, irregularity of the tank bottom and roughness of the inside of the tank, a small layer of liquid can remain clinging to the sloped bottom of a drain-dry tank. This layer of liquid will create vapor that can result in clingage losses. The amount of vapor produced within a drain-dry tank is directly related to this clingage. Clingage factors for various tank conditions are contained in Table 7.1-10. However, the clingage factors given in Table 7.1-10 are for the vertical shell of the tank, which is wiped by the rim seal each time the tank is emptied. The bottom of the tank is more nearly horizontal and is not wiped by a rim seal, and thus the clingage factors for a vertical shell would not be directly applicable. A clingage factor of 0.15 bbl/10³ft² should be used to represent the clingage on the tank bottom.

Standing Idle Loss for Tanks with a Liquid Heel

A constraint on the standing idle loss is added for floating roof tanks with a liquid heel in that the total emissions cannot exceed the available stock liquid in the tank. This upper limit, represented as L_{SLmax} , is a function of the volume and density of the liquid inside the tank.

$$L_{SLmax} = (\text{area of tank}) (\text{height of liquid}) (\text{density of liquid}) \quad (3-2)$$

Assuming that the tank has a circular bottom and adding a volume conversion unit, the equation can be simplified to Equation 3-3 and Equation 3-4.

$$L_{SLmax} = \frac{\pi}{4} D^2 h_{ie} W_L 7.48 \quad (3-3)$$

$$L_{SLmax} = 5.9 D^2 h_{ie} W_L \quad (3-4)$$

where:

- L_{SLmax} = limit on standing idle loss, lb per landing episode
- 5.9 = combination of constants ($\pi/4$) and 7.48 gal/ft³
- D = diameter of the tank, feet
- h_{ie} = effective height of the stock liquid, feet (See Table 7.1-4)

W_L = density of the liquid inside the tank, lb/gal

Internal or Domed External Floating Roof Tank with a Liquid Heel

For internal or domed external floating roof tanks with liquid heels, the amount of “standing idle loss” depends on the amount of vapor within the vapor space under the floating roof. Essentially, the mechanism is identical to the breathing losses experienced with fixed roof tanks. The mechanism shown in Equation 3-5 is identical to Equation 1-2.

$$L_{SI} = 365 V_V W_V K_E K_S \quad (3-5)$$

where

L_{SI} = annual breathing loss from standing idle during roof landing, lb/yr

365 = number of days in a year, days/yr

V_V = volume of the vapor space, ft³ (See Eq. 1-3)

W_V = stock vapor density, lb/ft³

$$W_V = \frac{M_V P_{VA}}{R T_V} \quad (3-6)$$

M_V = stock vapor molecular weight, lb/lb-mole

P_V = true vapor pressure of the stock liquid, psia at the temperature beneath the landed floating roof (given that the tank bottom is in contact with the ground, assume the temperature to be equal to ground temperature, which is taken as the average ambient temperature for the month in which the landing occurs, unless a different temperature is known)

R = ideal gas constant, 10.731 (psia-ft³)/(lb-mole °R)

T_V = average vapor temperature, °R, given that the tank bottom is in contact with the ground, the temperature is assumed to be equal to ground temperature, which is taken as the average ambient temperature for the month in which the landing occurs, unless a different temperature is known

K_E = vapor space expansion factor, per day, calculated from Equation 1-5, 1-12 or 1-13 as appropriate, with the value of ΔP_B set equal to zero

K_S = standing idle saturation factor, dimensionless, calculated from Equation 1-23.

This equation requires adjustment, however, in that floating roof landing episodes are measured in days rather than years. Assuming that n_d equals the number of days that the tank stands idle and substituting for the stock vapor density according to Equation 3-6, the equation is further simplified to Equation 3-7.

$$L_{SI} = n_d K_E \frac{P_{VA} V_V}{R T_V} M_V K_S \quad (3-7)$$

where

- L_{SL} = annual breathing loss from standing idle during roof landing, lb/yr
- nd = number of days that the tank stands idle, days
- K_E = vapor space expansion factor, per day, calculated from Equation 1-5, 1-12 or 1-13 as appropriate, with the value of ΔP_B set equal to zero
- P_V = true vapor pressure of the stock liquid, psia at the temperature beneath the landed floating roof (given that the tank bottom is in contact with the ground, assume the temperature to be equal to ground temperature, which is taken as the average ambient temperature for the month in which the landing occurs, unless a different temperature is known)
- V_V = volume of the vapor space, ft³ (See Eq. 1-3)
- R = ideal gas constant, 10.731 (psia-ft³)/(lb-mole °R)
- T_V = average vapor temperature, °R, given that the tank bottom is in contact with the ground, the temperature is assumed to be equal to ground temperature, which is taken as the average ambient temperature for the month in which the landing occurs, unless a different temperature is known
- M_V = stock vapor molecular weight, lb/lb-mole
- K_S = standing idle saturation factor, dimensionless, calculated from Equation 1-23.

The term with the highest amount of uncertainty is the saturation of the vapor beneath the landed floating roof. The standing idle saturation factor, K_S , is estimated with the same method used to calculate the vented vapor saturation factor for fixed roof tanks in Equation 1-23. In order to establish limits on the value of K_S , the estimated factor is assumed to be less than or equal to the filling saturation factor (S). (For more information see Filling Losses.)

The bottom of the tank may be flooded with a light distillate material, such as diesel, to reduce volatility when the original heel is a relatively volatile liquid such as gasoline. This procedure is referred to as distillate flushing. Testing has shown that, when the characteristics of the liquid heel beneath a landed floating roof are changed, the characteristics of the vapor space beneath the floating roof will tend toward equilibrium with the new liquid heel within 24 hours. The values for K_E , P_{VA} , and M_V in Equation 3-7 may, then, be based on the properties of the mixture resulting from distillate flushing the day following the introduction of the distillate into the tank. Properties of this mixture would be a weighted average of the properties of the original heel and the properties of the distillate material, proportional to the remaining quantities of each.

External Floating Roof Tank with a Liquid Heel

For external floating roof tanks with a liquid heel, wind affects emission releases from the tanks. As a starting point, begin with a basic equation based on rim-seal loss. The equation, shown as Equation 3-8, is equivalent to Equation 2-3.

$$L_{RL} = (K_{Ra} + K_{Rb} v^n) D P^* M_V K_C \quad (3-8)$$

where

- L_{RL} = annual rim seal loss during roof landing, lb/yr
- K_{Ra} = zero wind speed rim seal loss factor, lb-mole/ft-yr

- K_{Rb} = wind speed dependent rim seal loss factor, lb-mole/((mph)ⁿ-ft-yr)
- n = seal-related wind speed loss exponent, dimensionless
(K_{Ra} , K_{Rb} , and n are specific to a given configuration of rim seal, see Table 7.1-8)
- v = average ambient wind speed, mph
- D = tank diameter, ft
- M_v = stock vapor molecular weight, lb/lb-mole
- K_C = product factor, dimensionless
- P^* = a vapor pressure function, dimensionless

$$P^* = \frac{\frac{P_{VA}}{P_A}}{\left(1 + \left[1 - \left(\frac{P_{VA}}{P_A}\right)\right]^{0.5}\right)^2} \quad (3-9)$$

where:

- P_A = atmospheric pressure, psia
- P_{VA} = true vapor pressure of the stock liquid, psia.

Assuming that the stock properties included in the vapor pressure function will adequately account for differences in liquid product type, K_C is assumed to equal 1. Regardless of the type of rim seal that is in use, it is effectively rendered a ‘vapor-mounted’ seal when the liquid level falls such that the rim seal is no longer in contact with the liquid. The contribution of a secondary seal is neglected in that it is offset by emissions through the deck fittings. The emissions are therefore based on the case of a welded tank with an average-fitting vapor-mounted primary seal. According to Table 7.1-8, the values of K_{Ra} , K_{Rb} , and n are 6.7, 0.2, and 3.0, respectively. The variables were substituted and the equation was converted from annual emissions to daily emissions by dividing the equation by 365. A value of 10 mph is assigned to the wind speed, so that estimated standing idle losses from an external floating roof tank will not be less than for a typical internal or domed external floating roof tank. Lower values for the rim seal loss factors or the wind speed should not be used. The equation for standing idle loss due to wind can be simplified to Equation 3-10.

$$L_{SL\ wind} = 0.57 n_D DP^* M_v \quad (3-10)$$

where:

- L_{SLwind} = standing idle loss due to wind, lb per landing episode
- 0.57 = daily rim seal factor: $(K_{Ra} + K_{Rb} v^n)/365$
where $K_{Ra} = 6.7$, $K_{Rb} = 0.2$, $v = 10$, and $n = 3.0$
- n_d = number of days that the tank is standing idle, days
- D = tank diameter, ft
- P^* = a vapor pressure function, dimensionless
- M_v = stock vapor molecular weight, lb/lb-mole

As with internal or domed external floating roof tanks with a liquid heel, distillate flushing may be used to reduce the volatility of the liquid heel and thus the values used for the stock properties. The value for M_V , and for P_{VA} in the calculation of P^* , may be based on the properties of the mixture resulting from distillate flushing the day following the introduction of the distillate into the tank.

After the wind empties the vapor space above the remaining liquid heel, the liquid will continue to produce vapor. Thus, this standing idle loss will occur every day that the tank stands idle with liquid remaining in the tank. This equation is adequate at this time but could be revised as additional testing is conducted and studied.

Limit on Standing Idle Losses from Drain-Dry Tanks

When a drain-dry tank has been emptied, the only stock liquid available inside the tank is a thin layer that clings to the wetted surface of the tank interior (if free-standing liquid remains in or near a sump, or in puddles on the tank bottom, then the tank should be evaluated as having a partial heel, and not as drain dry – see Figure 7.1-20). The slope prevents a significant amount of stock liquid from remaining in the tank so that evaporation is much lower than from tanks with liquid heels. Due to the limited amount of liquid clinging to the interior of the tank, as shown in Figure 7.1-20, there would be no liquid remaining to replenish vapors once the clingage layer has evaporated. For this model, standing idle loss due to clingage is a one-time event rather than a daily event, involving only evaporation of the clingage layer.

The loss due to clingage is proportional to a clingage factor, which varies with the condition of the inside of the tank. A list of clingage factors are shown in Table 7.1-10. However, the clingage factors given in Table 7.1-10 are for the vertical shell of the tank, which is wiped by the rim seal each time the tank is emptied. The bottom of the tank is more nearly horizontal and is not wiped by a rim seal, and thus the clingage factors for a vertical shell would not be directly applicable to the tank bottom.

The factors are given in terms of barrels per thousand square feet. To convert the loss to pounds, the density of the liquid and the area of the tank bottom must be taken into account, as shown in Equation 3-11.

$$L_C = 0.042 C_S W_L Area \quad (3-11)$$

where:

- L_C = clingage loss from the drain-dry tank, lb
- 0.042 = conversion factor, 1,000 gal/bbl
- C_S = clingage factor, bbl/1,000 ft²
- W_L = density of the liquid, lb/gal
- Area = area of the tank bottom, ft²

$$Area = \left(\frac{\pi D^2}{4} \right) \quad (3-12)$$

Among the conditions shown in Table 7.1-10, the one that best approximates a sludge-lined tank bottom is gunite-lined, particularly given that the tank bottom is nearly horizontal and is not wiped by a rim seal. Assuming that gasoline is being stored in the tank, a clingage factor of 0.15 and the area term in Equation 3-12 were substituted into Equation 3-11, which simplifies to Equation 3-13.

$$L_{SL} = 0.0063 W_L \frac{\pi D^2}{4} \quad (3-13)$$

The clingage loss should be constrained by an upper limit equal to the filling loss for an internal or domed external floating roof tank with a liquid heel. This is demonstrated in Equation 3-14.

$$L_{SLmax} = 0.60 \frac{P_{VA} V_V}{R T_V} M_V \quad (3-14)$$

where:

- L_{SLmax} = maximum standing idle loss for drain-dry tanks due to clingage, lb
- W_L = density of the liquid inside the tank, lb/gal
- D = diameter of the tank, feet
- P_{VA} = true vapor pressure of the liquid inside the tank, psia
- V_V = volume of the vapor space, ft³ (See Eq. 1-3)
- R = ideal gas constant, 10.731 psia ft³ /lb-mole °R
- T_V = average temperature of the vapor and liquid below the floating roof, °R (= T_{AA})
- M_V = stock vapor molecular weight, lb/lb-mole

Therefore, the standing idle loss for drain-dry tanks, shown in Equation 3-13, must be less than or equal to Equation 3-14. This relationship is shown by Equation 3-15.

$$L_{SL} \leq 0.60 \frac{P_{VA} V_V}{R T_V} M_V \quad (3-15)$$

7.1.3.3.2 Filling Losses

When a floating roof tank is refilled, there are additional emissions resulting from the roof being landed. These losses are called “filling losses” and continue until the liquid reaches the level of the floating roof.

The first contributor to filling losses is called the “arrival” component. These are the vapors that remain under the floating roof at the end of the standing idle period but have not been accounted for as standing idle losses. For example, in the case of a liquid heel evaporation takes place into the vapor space beneath the landed floating roof. The vapors that are expelled from this vapor space by breathing are accounted for as standing idle losses, and the vapors that remain upon the commencement of refilling are deemed the arrival component of filling losses.

The second contributor to filling losses is called the “generated” component. These are the vapors created by the incoming liquid as it evaporates during the filling operation. Even when filling a completely clean and gas-free tank, the incoming liquid will generate a certain amount of vapors.

Limit on Filling Loss for Tanks with a Liquid Heel

A constraint on the filling loss is added for floating roof tanks with a liquid heel in that the total emissions cannot exceed the amount of stock liquid initially left in the tank less the amount attributed to standing idle loss, plus the vapors generated by incoming liquid upon refilling. This upper limit, represented as L_{FLmax} , may be determined as follows:

- Initial amount of stock liquid = $5.9 h_{le} W_L$ from Equation 3-4
- Amount attributed to standing idle loss = L_{SL} from the applicable equation above for the given type of tank
- Amount generated by incoming liquid = $0.15 P_{VA} V_V M_V / R T_V$
from Equation 3-18 evaluated for a drain-dry tank, to account for only the generated component of vapors

These components of the upper limit on filling loss for a tank with a liquid heel may be combined into the following equation:

$$L_{FL} \leq (5.9 D^2 h_{le} W_L) - L_{SL} + 0.15 \frac{P_{VA} V_V}{R T_V} M_V \quad (3-16)$$

General Equation for Filling Loss

The amount of vapor that is lost during filling is directly related to the volume of the vapor space and the saturation level of the vapor within the vapor space, as shown in Equation 3-17.

$$L_{FL} = (\text{vapor space volume}) (\text{vapor concentration}) (\text{vapor mol wt}) (\text{saturation factor}) \quad (3-17)$$

After substituting for the major terms in Equation 3-17, the equation can be simplified to Equation 3-18.

$$L_{FL} = \left(\frac{P_{VA} V_V}{R T_V} \right) M_V (C_{gf} S) \quad (3-18)$$

where:

- L_{FL} = filling loss during roof landing, lb
- P_{VA} = true vapor pressure of the liquid within the tank, psia
- V_V = volume of the vapor space, ft³ (See Eq. 1-3)
- R = ideal gas constant, 10.731 psia-ft³/(lb-mole-°R)

- T_v = average temperature of the vapor below the floating roof, °R (see Equation 3-6)
- M_v = stock vapor molecular weight, lb/lb-mole
- C_{sf} = filling saturation correction factor for wind, dimensionless
- S = filling saturation factor, dimensionless (0.60 for a full liquid heel; 0.50 for a partial liquid heel).

In the event of a change of service during the landing event, the equation should be run separately for the arrival and generated components. The arrival component should be based on the liquid properties of the prior service and a saturation factor of ($C_{sf} S - 0.15$). The generated component should be based on the properties of the incoming liquid and a saturation factor of 0.15.

Internal or Domed External Floating Roof Tank with a Liquid Heel

A value of 0.6 for the filling saturation factor (S), which is used in Section 5.2, Table 5.2-1 for submerged loading of tank trucks and rail cars, has been demonstrated to be suitable for the case of a full liquid heel. A value of 0.5 has been demonstrated for the case of a partial liquid heel. In that the landed floating roof in an internal or domed external floating roof tank is shielded from wind by the fixed roof, the value of C_{sf} is taken as 1.0.

External Floating Roof Tank with a Liquid Heel

For external floating roof tanks with a liquid heel, the amount of vapor lost during filling will be less than the amount for internal or domed external floating roof tanks because of wind effects. The “arrival” component will have been partially flushed out of the tank by the wind, so the preceding equation requires evaluation of the filling saturation correction factor for wind, C_{sf} . The basic premise of the correction factor is that the vapors expelled by wind action will not be present in the vapor space when the tank is refilled, so the amount of saturation is lowered. This is demonstrated in Equation 3-19.

$$C_{sf} = 1 - \frac{(\text{one day of wind driven standing idle loss}) - (\text{one day without wind standing idle loss})}{\text{one day without wind total loss}} \quad (3-19)$$

The equation for the filling saturation correction factor can be simplified based on other equations contained in this section as shown in Equation 3-20 and Equation 3-21.

$$C_{sf} = 1 - \left(\frac{(\text{Equation 3-10}) - (\text{Equation 3-7})}{(\text{Equation 3-7}) + (\text{Equation 3-18})} \right) \quad (3-20)$$

Substituting the indicated equations, with the number of days set equal to 1 and C_{sf} set equal to 1 in Equation 3-18 for the case without wind:

$$C_{sf} = 1 - \left(\frac{(0.57 \cdot 1 \cdot D \cdot P^* \cdot M_V) - \left(1 \cdot K_E \cdot \left(\frac{P_{VA} \cdot V_V}{R \cdot T_V}\right) \cdot M_V \cdot K_S\right)}{\left(1 \cdot K_E \cdot \left(\frac{P_{VA} \cdot V_V}{R \cdot T_V}\right) \cdot M_V \cdot K_S\right) + \left(\left(\frac{P_{VA} \cdot V_V}{R \cdot T_V}\right) \cdot M_V \cdot (1 \cdot S)\right)} \right) \quad (3-21)$$

where:

C_{sf} = filling saturation correction factor for wind, dimensionless

n_d = set equal to 1, days

K_E = vapor space expansion factor, per day, calculated from Equation 1-5, 1-12 or 1-13 as appropriate, with the value of ΔP_B set equal to zero

V_V = volume of the vapor space, ft³

$$V_V = \frac{h_v \pi D^2}{4} \quad (3-22)$$

h_v = height of the vapor space under the floating roof, ft

D = tank diameter, ft

R = ideal gas constant, 10.731 psia-ft³/(lb-mole-°R)

M_V = stock vapor molecular weight, lb/lb-mole

K_S = standing idle saturation factor, dimensionless

S = filling saturation factor, dimensionless

P^* = vapor pressure function, dimensionless

Drain-Dry Tanks

The “arrival” component of filling losses for drain-dry tanks is completely covered by the “clingage” loss. Once this initial loss occurs, there is no remaining liquid inside the tank. Therefore, any vapors remaining in the tank prior to introducing the incoming liquid would have already been accounted for as standing idle loss, and thus saturation of the arrival component for drain-dry tank filling losses is taken as 0. Similarly, a tank with a full or partial liquid heel for which evaporation of the entire heel has been accounted for as standing idle loss should be considered to have no arrival component of filling losses, nor should a tank that has been cleaned. Each of these scenarios is deemed “drain dry” for purposes of estimating the filling loss.

However, the “generated” component remains a valid aspect of the model. Therefore, the filling saturation factor will be lower for drain-dry tanks than for tanks with a liquid heel due to the lack of an “arrival” component. And, given the absence of an arrival component of vapors for filling loss, the filling saturation correction factor for wind is taken as 1.0.

AP-42 Chapter 5, *Petroleum Industry*, provides emission factors for the loading of gasoline and crude oil into compartments according to the prior state of the compartment. A drain-dry tank would be most similar to a tank that was cleaned before filling because a cleaned tank also lacks “arrival” losses. The emission factor (0.33 lb/1000 gallons) for this kind of tank can be converted to a saturation factor by

assuming a pressure of 8 psia (the same assumption used in the formulation of the emission factor) and substituting the molecular weight of gasoline (64 lb/lb-mole). The resulting saturation factor of 0.15 is applied as the filling saturation factor for drain-dry tanks regardless of the stored liquid.

7.1.3.4 Tank Cleaning Emissions²³

The methodology presented in this section for estimating emissions associated with tank cleaning events is expressly for the estimation of vapors that are expelled from the tank during forced ventilation. These vapors potentially occur whenever forced ventilation of the tank is in operation while volatile organic material remains in the tank, regardless of whether any tank cleaning is actually taking place.

For purposes of estimating emissions, tank cleaning may be characterized as comprising the steps listed below.

Prior to commencement of forced ventilation (*i.e.*, not included in the tank cleaning calculations):

Normal Pumpout: As much stock liquid as possible is pumped out through the tank outlet in the normal manner (*i.e.*, until the liquid level has dropped below the open end of the outlet line, and no more liquid moves through the outlet). If the tank has a floating roof, the floating roof will have landed on its legs and the vacuum breaker vent will have opened, causing air to be drawn into the space beneath the floating roof. Emissions that occur during normal pumpout are accounted for as routine emissions for fixed-roof tanks and as floating roof landing losses for floating roof tanks, and thus the normal pumpout period does not require additional calculations pertaining to tank cleaning.

Standing Idle: The tank may remain in the condition resulting from normal pumpout for some period of time until the next step begins. Emissions that occur during this period are accounted for as routine standing (breathing) loss for fixed roof tanks, and as standing idle loss during a floating roof landing for floating roof tanks, and thus the standing idle period does not require additional calculations pertaining to tank cleaning.

During forced ventilation (these are the steps for which additional tank cleaning calculations are required):

- a) Vapor Space Purge: When eductors, fans, or blowers are started up, either at the top of the tank or at a shell manhole, cleanout fitting or other shell fitting, the first air change is deemed to expel those vapors that remain from the prior standing idle period. This first air change is characterized as a purge of vapors from the tank. Emissions associated with subsequent air changes are accounted for under continued forced ventilation.

A vapor space purge will occur each time that ventilation commences after a period of standing idle without forced ventilation.

- b) Continued Forced Ventilation: Forced ventilation refers to the removal of vapors from a tank by means of eductors, fans, or blowers. As long as volatile materials remain in the tank, some portion of the volatile material will evaporate into the air being moved through the tank by forced ventilation. The forced ventilation will then expel these vapors from the tank.

If forced ventilation is discontinued, such as during the overnight period, then the tank is returned to a standing idle condition. A subsequent restarting of forced ventilation will result in another vapor space purge followed by a period of continued forced ventilation.

After the tank is clean and gas free, even if forced ventilation is continuing (not included in the tank cleaning calculations):

Remain Clean: Once the tank has been rendered clean and gas free it may remain in the clean condition for some period of time. While forced ventilation may continue, there would be no further emissions in that there would be no remaining sources of vapors once the tank has been cleaned. Thus the period of remaining clean does not require additional calculations pertaining to tank cleaning.

Refilling: If the tank is subsequently refilled, there will be vapors generated by the incoming stock which would then be expelled from the tank by the rising liquid level. For a fixed roof tank, these refilling emissions are accounted for as routine working (filling) losses. For a floating roof tank, these refilling emissions are calculated in the same manner as for the refilling after a floating roof landing. In that the tank has been cleaned, the filling saturation factor for the refilling should be 0.15, as for a drain dry tank. The refilling losses, then, do not require additional methodology in this section pertaining to tank cleaning.

The emissions to be accounted for in this section on tank cleaning emissions, then, are those associated with forced ventilation while volatile material remains in the tank. The equations needed to estimate emissions resulting from forced ventilation during tank cleaning are contained in Tables 7.1-20 and 7.1-21; equations for the vapor space purge are contained in Table 7.1-20 and equations for continued forced ventilation are contained in Table 7.1-21. The following sections explain these equations in more detail.

$$L_{FV} = L_P + L_{CV} \quad (4-1)$$

where:

L_{FV} = total emissions due to forced ventilation during a tank cleaning event, lb

L_P = vapor space purge emissions associated with the first air change following commencement of forced ventilation, lb

L_{CV} = emissions from continued forced ventilation following the first air change, lb

7.1.3.4.1 Vapor Space Purge Emissions

The daily breathing cycle that produces the standing idle emissions causes only a portion of the vapors in the vapor space to be expelled from the tank. The vapors that remain in the vapor space are not accounted for in the calculation of standing idle emissions. Commencement of forced ventilation expels these remaining vapors from the tank. The first air change of the vapor space upon commencing forced ventilation may be referred to as the vapor space purge, and the emissions may be estimated as follows:

$$L_P = \left(\frac{P_{VA} V_V}{R T_V} \right) M_V S \quad (4-2)$$

where:

- P_{VA} = the true vapor pressure of the exposed volatile material in the tank (psia) [See Eq 1-27 or Eq 1-28],
- V_V = volume (ft³) of the vapor space,
- R = ideal gas constant, 10.731 psia-ft³/(lb-mole-°R),
- T_V = the average temperature of the vapor space (°R),
= the average ambient temperature (°R),
- M_V = the stock vapor molecular weight (lb/lb-mole),
- S = is a saturation factor evaluated as a function of the tank type and heel condition, as discussed later in this section

The volatility of the remaining materials may be less than the volatility of the previously stored stock liquid, and thus an appropriate judgment should be made in assigning properties to the residual material in the tank bottom for purposes of determining values for the true vapor pressure, P_{VA} , and the stock vapor molecular weight, M_V .

The bottom of the tank may be flooded with a light distillate material, such as diesel, to facilitate removal of sludge from the bottom of the tank. This procedure is referred to as distillate flushing. Testing has shown that, when the characteristics of the liquid heel beneath a landed floating roof are changed, the characteristics of the vapor space beneath the floating roof will tend toward equilibrium with the new liquid heel within 24 hours. The values for P_{VA} and M_V in Equation 4-2 may, then, be based on the properties of the mixture resulting from distillate flushing the day following the introduction of the distillate into the tank. Properties of this mixture would be a weighted average of the properties of the original heel and the properties of the distillate material, proportional to the remaining quantities of each.²⁴

The vapor space purge comprises the expulsion of one vapor space volume, similar to one working-loss (filling) cycle of the vapor space. Emissions associated with subsequent air changes are accounted for as continued forced ventilation emissions.

Fixed Roof Tanks

The volume of the vapor space for estimating working loss from a fixed-roof tank is calculated from the maximum liquid height to which the tank may be filled. For a vapor space purge, however, the volume of the vapor space is the entire volume under the tank roof:

$$VV = HVO (\pi D^2/4) \quad (4-3)$$

where:

H_{VO} = the fixed-roof tank vapor space outage (ft)

$$HVO = H_S - h_l + H_{RO} \quad (4-4)$$

where:

H_S = the height of the tank shell (ft),

h_l = the height of the stock liquid and sludge above the tank bottom at the tank shell (ft),
and

H_{RO} = the roof outage (the effective height of the vapor space enclosed by the tank roof, ft)
= $S_R D/6$ for a cone-shaped roof, where S_R is the roof slope in feet per foot.

The vapor space outage, H_{VO} , would be slightly greater for the case of a cone-down bottom in a tank that does not have a full liquid heel. The slope of bottoms tends to be much less than the slope of roofs, however, and the contribution of the bottom cone to the vapor space outage would be very small compared to the full shell height.

The saturation factor for filling a fixed-roof tank is given as the turnover factor, K_N , in Equation 1-37, and defined as:

$$K_N = (180 + N)/6N$$

where:

N = number of turnovers per year, dimensionless

It would be advantageous to express this saturation factor in terms of days between turnovers (*i.e.*, days standing idle, n_d). The number of days between turnovers may be expressed as follows:

$$n_d = \frac{365}{N}$$

and thus the equation for K_N may be rewritten as:

$$K_N = (0.5 n_d + 1) / 6 \quad (4-5)$$

Recognizing that the turnover factor, K_N , is the saturation factor to be used for calculating filling losses from a fixed-roof tank, the saturation factor, S , may be substituted for the turnover factor, K_N .

$$S = (0.5 n_d + 1) / 6 \quad (4-6)$$

For periods of less than one day, a value of 1 should be used for the standing idle time, n_d . This effectively imposes a minimum value of 0.25 for the saturation factor, S . Thus a value of 0.25 should be used for S when the vapor space purge follows a standing idle period that was limited to an overnight cessation of forced ventilation.

The saturation factor value of 0.5 for an internal or domed external floating roof tank with a partial heel, as shown in Equation 3-18, may be reasonably chosen as an upper bound on the value of S for a fixed roof tank vapor space purge. It would be expected, for a given diameter of tank and type of liquid heel, that the accumulated vapors would be less concentrated in the larger vapor space of the fixed roof tank than under a landed floating roof, and thus a value of 0.5 should be a conservative upper bound for the fixed roof tank vapor space purge saturation factor.

These limits are expressed as follows:

$$S \geq 0.25 \quad (4-7)$$

$$S \leq 0.5 \quad (4-8)$$

Floating Roof Tanks

The volume of the vapor space for estimating the vapor space purge loss from a floating-roof tank is limited to the space under the floating roof, in that vapors which escape past the floating roof prior to the commencement of forced ventilation are separately accounted for as standing idle loss from the floating roof landing event:

$$\begin{aligned} VV &= \text{volume (ft}^3\text{) of the vapor space under the floating roof} \\ &= (h_v) (\pi D^2/4), \end{aligned} \quad (4-9)$$

where:

h_v = the height (ft) of the vapor space under the floating roof for the given vapor space purge (see Table 7.1-4)

The saturation factor, S , for the initial vapor space purge is evaluated as specified for the filling saturation factor for a floating roof landing. This approach is conservative in that filling losses have both an arrival component, from resident vapors, and a generated component, from vapors generated by incoming liquid (*e.g.*, 25% of the filling saturation factor for an internal or domed external floating-roof tank with a full liquid heel may be attributable to the incoming liquid – the contribution of the incoming liquid to the vapor concentration varies with the filling scenario). The vapor space purge does not involve incoming liquid, however, and therefore would have only the arrival component of vapors. It is conservative, therefore, to use saturation factors that include allowance for the generated component of vapors.

When forced ventilation is discontinued overnight, then the tank cleaning process will involve a daily cycle that includes a period of standing idle (overnight) followed by a vapor space purge (when forced ventilation resumes the next morning). Emissions from overnight standing idle periods are accounted for in the estimate of the next morning's vapor space purge. In that the overnight standing idle emissions are taken as zero, there is no accounting for wind-driven losses of vapor from under external floating roofs. These vapors must then be accounted for with the following morning's vapor space purge. That is, the neglect of wind driven emissions during the overnight period means that the vapors must be considered to still be present when estimating the next morning's vapor space purge, and thus there must be no factoring down of the saturation level for the case of external floating-roof tanks. In other words, C_{sf} should be taken as 1.0 when the vapor space purge follows a standing idle period that was limited to an overnight cessation of forced ventilation.

Saturation factor values to be used for floating roof tanks are summarized as follows:

Full liquid heel

Internal or domed external floating roof tank

$$S = 0.6$$

External floating roof tank

$$S = (0.6 C_{sf}), \text{ where } C_{sf} \text{ is evaluated as shown in Equation 3-21 with } n_d \text{ set to 1 for the initial vapor space purge; for subsequent vapor space purges that follow a cessation of forced ventilation overnight, } C_{sf} \text{ shall be taken as 1.0}$$

Partial liquid heel

Internal or domed external floating roof tank

$$S = 0.5$$

External floating roof tank

$$S = (0.5 C_{sf}), \text{ where } C_{sf} \text{ is evaluated as shown in Equation 3-21 with } n_d \text{ set to 1 for the initial vapor space purge; for subsequent vapor space purges that follow a cessation of forced ventilation overnight, } C_{sf} \text{ shall be taken as 1.0}$$

If all free flowing liquid has been removed, and only sludge remains, use the saturation factor for a partial heel, in that there is still volatile material in the tank but not free liquid across the entire bottom.

If the heel condition is drain dry, use a saturation factor value of 0, in that evaporation of the clingage would have already been accounted for in the estimation of the floating roof landing losses.

7.1.3.4.2 Continued Forced Ventilation Emissions

The calculation of vapor space purge emissions account for the vapors that are expelled by the first air change of the vapor space upon commencing forced ventilation at the end of a standing idle period. There may still be volatile materials remaining in the tank, however, that will continue to evaporate and generate vapors, and these additional vapors are expelled by continued forced ventilation.

Continued forced ventilation emissions are calculated from the average vapor concentration in the vapor space (which may be reported as a percent of the lower explosive limit, or %LEL), the ventilation rate, and the length of time during which forced ventilation continues to operate. These parameters are often known since they may be monitored for safety reasons.

The vapor concentration may be approximated from the reading of an LEL monitor, which is generally displayed as a percent of the LEL for the gas to which the monitor has been calibrated. LEL values for selected calibration gases are given in Table 7.1-5. The vapor concentration may also be approximated from the reading of an organic or toxic vapor analyzer, which may be displayed in parts per million by volume as the calibration gas.

To determine the vapor concentration from a %LEL reading, the LEL of the calibration gas is multiplied by the reading from the LEL monitor, after each has been divided by 100 to convert from a percent to a decimal fraction. This gives a volume concentration (mole fraction) in terms of the calibration gas. This concentration is corrected by a response factor (RF) to account for the difference in the sensitivity of the LEL monitor to the actual vapors as compared to its sensitivity to the calibration gas. When the response factor is unknown, use a value of one (RF = 1.0).

If the vapor concentration is very low, it may be below the minimum detection level of the LEL monitor. In this case, it may be reasonable to use half the minimum detection level as the %LEL for determining the vapor concentration.

In order to estimate the mass of vapors that are expelled from the tank by continued forced ventilation, the vapor concentration in terms of volume must be converted to vapor density in terms of mass. In order to convert vapor concentration to density, use the molecular weight of the calibration gas for the LEL monitor. Uncertainty is reduced if the molecular weight of the calibration gas is similar to the molecular weight of the stock vapors.

The continued forced ventilation emissions (L_{CV}) estimated by the vapor concentration method are:

$$L_{CV} = 60 Q_V n_{CV} t_V C_V \left(\frac{P_a M_{CG}}{RT_V} \right) \quad (4-10)$$

where:

- 60 = conversion of hours to minutes, min/hr
- Q_V = average ventilation rate during continued forced ventilation, ft³/min [Note: The nominal rated capacity of eductors, fans, or blowers should be factored by the resistance associated with ductwork or other obstructions in order to estimate the actual air flow rate. Fan capacity may be governed by a required number of air changes per hour.]
- n_{CV} = the duration of continued forced ventilation, days
- t_V = the daily period of forced ventilation, hr/day [Note: Do not include the initial time for the vapor space purge. It would be reasonable to neglect the first half hour from each stage of continued forced ventilation],

- C_v = average vapor concentration by volume during continued forced ventilation, dimensionless
 = (average LEL as displayed) (LEL of the calibration gas) RF
 “average LEL as displayed” is the average of the % LEL readings during a given stage of continued forced ventilation, divided by 100 to convert to a decimal fraction; LEL readings from the first half hour may be neglected in the determination of an average value
 “LEL of the calibration gas” is the LEL of the gas used to calibrate the LEL monitor, expressed as a decimal fraction
 RF = response factor, dimensionless
 = 1.0 if unknown. EPA Method 21 allows usage of a vapor monitoring instrument without correction for the response factor, as long as the response factor is less than 10 (40 CFR Part 60 Appendix A-7, Method 21, paragraph 8.1.1.2).
 Alternatively, C_v may be obtained from an organic vapor analyzer or toxic vapor analyzer that displays directly in terms of volume concentration, rather than displaying in terms of LEL.
 P_a = atmospheric pressure at the tank location, psia
 M_{CG} = calibration gas molecular weight, lb/lb-mole
 R = ideal gas constant
 = 10.731 psia-ft³/(lb-mole °R),
 T_v = average temperature of the vapor below the floating roof, ° R
 = the average ambient temperature, ° R

The vapor concentration (C_v) is limited by saturation of the vapor space. This limit may be expressed as:

$$C_v \leq \frac{P_{VA}}{P_a} \quad (4-11)$$

where:

- C_v = vapor concentration
 P_{VA} = the true vapor pressure of the exposed volatile material in the tank, psia
 P_a = atmospheric pressure

The estimate of continued forced ventilation emissions should be compared to an upper limit equal to the total weight of volatile sludge remaining in the tank. While there is free-standing stock liquid remaining in the tank, the sludge may conservatively be assumed to consist entirely of stock liquid in establishing the emissions upper limit. This limit is expressed as follows:

$$L_{CV} \leq 5.9D^2 h_{ie} W_L \quad (4-12)$$

where:

- D = the tank diameter, feet

- h_{ie} = the effective height of the stock liquid and sludge for the given stage of continued forced ventilation, ft (see Table 7.1-4)
- W_L = the density of the stock liquid, pounds per gallon
- 5.9 = combination of constants ($\pi/4$) and 7.48 gal/ft³

Once the free-standing stock liquid has been vacuumed out (or drained out, in the case of a drain-dry tank), however, much of the remaining sludge consists of relatively non-volatile residue. The upper limit on emissions from the vacuumed-out condition may assume that 20% of the sludge is volatile. This limit is expressed as follows:

$$L_{CV} \leq \frac{\pi}{4} D^2 F_e d_s W_L \text{ ft}^2 \text{ in } \frac{\text{lb}}{\text{gal}} \frac{\text{ft}}{12 \text{ in}} 7.48 \frac{\text{gal}}{\text{ft}^3} \quad (4-13)$$

$$L_{CV} \leq 0.49 D^2 F_e d_s W_L$$

where:

- F_e = the fraction of the sludge with potential to evaporate (= 0.20 if unknown)
- d_s = the average depth of sludge, inches
- 0.49 = constant with units of gal/(in. ft²)

7.1.3.5 Flashing Loss²⁵

The equations in Section 7.1.3.1 for estimating routine emissions from fixed roof tanks do not address the scenario of a tank storing a liquid which contains gases that have the potential to flash out of solution. This scenario occurs when a gas-liquid mixture has been under sufficient pressure to maintain the entrained gases in solution, but the mixture is then subjected to a drop in system pressure such that the pressure is no longer sufficient to maintain the gases in solution. The gases will then rapidly migrate out of the liquid, similar to carbon dioxide fizzing out of solution when a carbonated beverage container is opened. This escape of gases from the mixture is referred to as flashing.

The most common scenario for flashing in the petroleum industry is the storage of crude oil or condensate in the production field. Even though the produced well stream has typically been processed by one or more separators prior to produced liquids being deposited into a storage tank, the exit pressure from the last stage separator may be significantly greater than the pressure in the first storage tank. Thus the produced liquid stream will experience a pressure drop upon entering the storage tank, and remaining gases will have the potential to flash out of solution in the tank. This scenario, then, has the potential for flashing losses in addition to routine standing and working losses.

There are numerous methodologies available for estimating flashing losses and specific guidance regarding their application and use. However, discussion of such methodologies is beyond the scope of this section. The accuracy of methods that rely on a site-specific sample is dependent on how representative the sample is of production from that site, and the accuracy of methods that rely on process simulation is dependent on how representative the modeling assumptions are of the actual conditions at the site. The conditions to be determined by sampling or modeling are of the crude oil or condensate properties at the last stage separator, in the oil compartment before the dump valve.

In addition to evaluating a tank with the potential for flashing losses, the tank must also be evaluated for routine standing and working losses as described in Section 7.1.3.1. If vapors are routed to a control device, the control efficiency of the device should be applied to the flashing loss as well as to the standing and working losses. If vapors are routed to a compressor for injection into a gas line or process, the control efficiency would be assumed to be 100% whenever the compressor is on-line.

7.1.3.6 Variable Vapor Space Tanks¹⁸

Variable vapor space filling losses result when vapor is displaced by liquid during filling operations. Since the variable vapor space tank has an expandable vapor storage capacity, this loss is not as large as the filling loss associated with fixed roof tanks. Loss of vapor occurs when the tank's vapor storage capacity is exceeded. Equation 6-1 assumes that one-fourth of the expansion capacity is available at the beginning of each transfer.

Variable vapor space system filling losses can be estimated from:

$$L_V = (2.40 \times 10^{-2}) \left(\frac{M_V P_{VA}}{V_1} \right) \left[(V_1) - (0.25 V_2 N_2) \right] \quad (6-1)$$

where:

L_V = variable vapor space filling loss, lb/1,000 gal throughput

M_V = molecular weight of vapor in storage tank, lb/lb-mole; see Note 1 to Equation 1-24

P_{VA} = true vapor pressure at the average daily liquid surface temperature, psia; see Notes 1 and 2 to Equation 1-24

V_1 = volume of liquid pumped into system, throughput, bbl/yr

V_2 = volume expansion capacity of system, bbl; see Note 1

N_2 = number of transfers into system, dimensionless; see Note 2

Notes on Equation 6-1:

Note 1. V_2 is the volume expansion capacity of the variable vapor space achieved by roof lifting or diaphragm flexing.

Note 2. N_2 is the number of transfers into the system during the time period that corresponds to a throughput of V_1 .

The accuracy of Equation 6-1 is not documented. Special tank operating conditions may result in actual losses significantly different from the estimates provided by Equation 6-1. For example, if one or more tanks with interconnected vapor spaces are filled while others are emptied simultaneously, all or part of the expelled vapors will be transferred to the tank, or tanks, being emptied. This is called balanced pumping or vapor balancing. Equation 6-1 does not account for balanced pumping and will overestimate losses under this condition. It should also be noted that, although not developed for use with heavier petroleum liquids such as kerosenes and fuel oils, the equation is recommended for use with heavier petroleum liquids in the absence of better data.

Variable vapor space tanks that rely on either a flexible diaphragm or a flexible coated fabric seal will have additional losses to the extent that vapors leak through or past the membrane used for the diaphragm or seal. The leakage rate through the membrane is a function of the permeability of the

fabric material from which the membrane is manufactured, and a leakage rate past the membrane is a function of the leak tightness of the seam or seams where the membrane is attached to the tank wall. These leakage rates depend upon the type of fabric used for the membrane and the manner in which the membrane is attached to the tank wall.

7.1.3.7 Pressure Tanks

Losses occur during routine operations in low-pressure (2.5 to 15 psig) tanks to the extent that atmospheric venting occurs. These losses are a function of the vent set pressure and are accounted for in the equations for routine fixed roof tank standing and working losses in Section 7.1.3.1. High-pressure tanks are considered closed systems, with virtually no emissions. Fugitive losses from high-pressure tanks are estimated as equipment leaks and are not addressed in the methodology for estimating storage tank emissions.

A blanket of nitrogen gas is sometimes maintained in a storage tank for either safety or product purity purposes, but the presence of the nitrogen gas does not reduce emissions. This is because hydrocarbons readily evaporate into a nitrogen atmosphere, as evidenced by the fact that ambient air is approximately 79% nitrogen. However, a nitrogen blanket is sometimes maintained in a closed or pressurized system. In such a case, while evaporation rates would not be affected by the presence of the nitrogen blanket, emissions may be reduced as result of the vapor space in the tank being tied to a closed or pressurized system.

7.1.3.8 Variations Of Emission Estimation Procedures

7.1.3.8.1 Time Periods Shorter Than One Year²⁶

All of the emission estimation procedures presented in Section 7.1.3 can be used to estimate emissions for shorter time periods by manipulating the inputs to the equations for the time period in question, with an associated increase in uncertainty when applying the equations to fewer tanks or shorter time periods. Using actual data, such as the measured liquid temperature and true vapor pressure of the stored liquid, can reduce the uncertainty in the emissions estimate.

For all of the emission estimation procedures, the true vapor pressure should be calculated from an average daily liquid surface temperature based on the appropriate temperature and insolation data for the time period over which the estimate is to be evaluated. For example, emission calculations for the month of June would be based only on the meteorological data for June. It is important to note that a 1-month time frame is recommended as the shortest time period for which emissions should be estimated using these methodologies.

In addition to the temperature and vapor pressure corrections, the constant in the standing loss equation for fixed roof tanks would need to be revised based on the actual time frame used. The constant, 365, is based on the number of days in a year. To change the equation for a different time period, the constant should be changed to the appropriate number of days in the time period for which emissions are being estimated.

The turnover factor in the working loss equation for fixed roof tanks would need to be extrapolated to an annual rate when estimating emissions for a time period other than one year. This would be a matter of dividing the number of turnovers during the given time period by the number of

days in the time period and then multiplying by 365. Also, the throughput would need to be changed from the throughput per year to the throughput during the time period for which emissions are estimated.

Other than changing the meteorological data and the vapor pressure data, the only changes needed for the floating roof rim seal, deck fitting, and deck seam losses would be to modify the time frame by dividing the individual losses by the appropriate number of days or months. The only change to the withdrawal losses would be to change the throughput to the throughput for the time period for which emissions are being estimated.

The issues that render the equations for routine emissions inappropriate for time periods shorter than one month include, but are not limited to, the following:

Temperature calculations are simplified. There are many parameters involved in a thermal balance model for a storage tank, some of which are listed below. It has been deemed suitable to assign default values to several of these parameters when the calculations are applied to a large population of storage tanks located over a wide geographical area for emissions that occur over the course of a year. However, actual values for these parameters for an individual storage tank configuration or location, or for a particular day of the year, may deviate significantly from the default values. Section 7.1.3.8.3 presents a more detailed discussion of parameters affecting thermal balance in a storage tank.

The angle of incident solar radiation (i.e., the solar declination).

Reflectivity of surrounding surfaces.

Height to diameter ratio of the tank.

Liquid level.

Ambient wind speed.

Thermal conductance of the floating roof.

Presence of a fixed roof (versus an open top).

Changes in the liquid bulk temperature. The parameters which are accounted for as variables in the equations for routine emissions are evaluated in a manner that does not account for short-term phenomena. For example, calculations of temperature variables in the equations for routine emissions are based on the liquid and vapor phases within the tank having achieved a state of thermal equilibrium. The calculations do not, however, account for how long it may take for thermal equilibrium to be achieved after there has been a change in the thermal balance, such as the receipt of a batch of liquid. It is demonstrated in the reference cited in Section 7.1.3.8.3 that a typical time period for approaching thermal equilibrium may be approximately nine days, and thus a tank that has received liquid within the prior nine days would be expected to not be in thermal equilibrium. If measured bulk temperature is used instead of the estimated bulk temperature when estimating emissions, the time for the liquid to reach thermal equilibrium becomes unimportant when estimating emissions on a shorter time-scale.

Changes in ambient temperature. As ambient temperature changes, there would be an associated change in the vapor space temperature and subsequently in the liquid surface temperature. There would, however, be a time lag between a change in the ambient temperature and the associated change in the liquid surface temperature. This time lag is deemed inconsequential for the estimation of

annual or monthly emissions but would be expected to be more significant for shorter periods of time. Shorter time periods would also be more significantly influenced by abrupt short-term meteorological phenomena, such as cooling due to cloud cover or precipitation.

Saturation factors. The saturation level of vapors in the headspace of a fixed roof tank is a similarly time-dependent phenomenon. The equations for routine emissions do not fully account for the time lag required to achieve saturation equilibrium in response to short-term fluctuations in the values of applicable parameters.

Vapor expansion rate. The calculation of standing loss for a fixed roof tank is based on the total amount of vapor expansion that is expected to occur between the coolest night time temperature and the warmest day time temperature. The equation does not, however, calculate the hourly rate at which the vapor expansion takes place or the distribution of vapor expansion over the course of a day. This hourly rate would be dependent on several of the variables noted in (a) above, as well as on whether the tank shell is insulated. As discussed above in Note 1 following Equation 1-5, a fixed roof tank with an insulated shell but an uninsulated roof would be expected to have sufficient capacity for heat exchange through the roof such that vapor space expansion would occur. However, the insulated shell may cause the vapor space expansion to have a different hourly pattern than would be expected in the case of an uninsulated tank shell.

Vent flow capacity. In addition to not calculating the hourly rate of vapor expansion, as noted above, the calculation of standing loss for a fixed roof tank does not take into account whether the flow capacity of the tank vents will further limit the hourly rate at which vapors will be expelled from the tank as a result of daytime vapor expansion.

Changes in barometric pressure. The equations for routine emissions consider the barometric pressure to be a constant for a given location, in that it has been deemed reasonable to use the average barometric pressure when estimating emissions over the course of a year. However, short-term changes in barometric pressure could impact short-term vapor expansion rates.

Fill rate. The calculation of working loss for a fixed roof tank is based on the total volume of vapor expelled over the course of a year, which can be thought of as the total number of tankfuls of vapor displaced. However, the equation does not account for the hourly rate at which a tank is filled.

Standing loss for floating roof tanks. The equations for calculating routine standing losses from floating roof tanks are based on the rate at which vapors migrate from the liquid below the floating roof to the tank headspace above the floating roof, and do not account for the rate at which these vapors may be eventually expelled from the tank.

Working loss for floating roof tanks. The calculation of working loss for a floating roof tank is based on the evaporation of the wetted surface that is left on the inside wall of the tank after lowering the liquid level. The calculation assumes that the entire film of liquid evaporates, but it does not account for the hourly rate at which the film of liquid evaporates or when the vapors are actually expelled from the tank.

Vapor space outage. The calculation of standing loss for a fixed roof tank is based on an assumed vapor space outage corresponding to the average liquid height. However, at any given point in time the tank may be nearly empty or nearly full, thus resulting in very different scenarios of vapor

space outage. For example, if the vapor space expansion factor is 0.15, that indicates 15% of the vapor space will be expelled by daytime warming and expelling 15% of the vapor space when the tank is nearly empty would constitute a far greater volume than 15% of the vapor space when the tank is nearly full.

Vented vapor saturation factor. The saturation factor used in the calculation of standing loss for a fixed roof tank is similarly dependent on the vapor space outage. Annual emission estimates are based on the average liquid height, but the calculation would indicate a lower vapor saturation when the tank is nearly empty and a higher vapor saturation when the tank is nearly full.

7.1.3.8.2 Internal Floating Roof Tanks with Closed Vent Systems²⁷

The equations for routine emissions from internal floating roof tanks assume the tank has open vents in the fixed roof. Estimation of emissions when an internal floating roof tank has closed pressure/vacuum vents is presented in API Technical Report 2569.

The adjustment to account for the closed pressure/vacuum vents in the estimate of emissions was found to be significant only for small diameter tanks storing relatively high volatility liquids with infrequent turnovers. When the volatility of the stored liquid is no greater than that of diesel, then the adjustment is generally less than 10% regardless of the tank diameter or the number of turnovers. When the tank diameter is 60 feet or greater and the number of turnovers per year is greater than 18, then the adjustment is generally less than 10% regardless of the volatility of the stored liquid. Given the high degree of uncertainty associated with these calculations, and the burden of performing them, it would be reasonable to apply a default reduction of 5% on the total estimated emissions to account for the use of closed vents on a floating roof tank in lieu of calculating a reduction specific to the given situation.

7.1.3.8.3 Case-Specific Liquid Surface Temperature Determinations²²

Several parameters pertaining to liquid surface temperature are assigned default values for incorporation into the equations for routine emissions. Methodology to account for selected parameters as variables in the estimation of emissions from a particular storage tank at a particular location is presented in API Manual of Petroleum Measurement Standards Chapter 19.4, Annex I.

7.1.3.8.4 Heating Cycles in Fully Insulated Fixed Roof Tanks⁸

The equations in Section 7.1.3.1.1 for standing loss from fixed roof tanks are based on the daily cycle of warming and cooling of the vapor space due to heat exchange between the vapor space and ambient air through the shell and roof of the tank. This heat exchange results in daytime expansion and nighttime contraction of vapors in the vapor space, with each expansion cycle causing some portion of the vapors to be expelled from the vapor space. The resulting emissions are referred to as breathing losses.

A similar cycle of expansion and contraction of vapors in the vapor space may be driven by cyclic heating of the bulk liquid. Even in a fully insulated storage tank, in which there is minimal heat exchange with ambient air, the temperature in the tank vapor space will cycle through a range if the bulk liquid is heated periodically. This could occur by occasionally receiving hot stock, which then cools over time prior to the next receipt of hot stock, or as a result of the tank being heated by some means that is periodically turned on and off.

For uninsulated tanks or for tanks with an insulated shell but an uninsulated roof, the effect of bulk liquid heating cycles on standing loss may be neglected because it may be random as to whether

cycles of heating the bulk liquid add to or subtract from the vapor space temperature variation driven by the diurnal ambient temperature cycle.

For fully insulated storage tanks, however, standing loss may be driven by cyclic heating of the bulk liquid. The equations for routine fixed roof tank breathing loss may be adapted to the case of cyclic heating of the bulk liquid, as shown below.

The annual breathing loss is calculated from Equation 1-4:

$$L_S = 365 K_E \left(\frac{\pi}{4} D^2 \right) H_{VO} K_S W_V \quad (1-4)$$

The variables in this equation should be evaluated for calculating heating cycle breathing losses in the same manner as described in Section 7.1.3.1.1 for routine breathing losses, except as noted below.

The constant 365 is the number of days in a year. In that heating cycle breathing is an event that is a function of the frequency of the heating cycle, rather than being a daily phenomenon, replace the constant 365 with the number of heating cycles in the given time period.

The vapor space expansion factor K_E is calculated from Equation 1-5:

$$K_E = \frac{\Delta T_V}{T_{LA}} + \frac{\Delta P_V - \Delta P_B}{P_A - P_{VA}} > 0 \quad (1-5)$$

In a fully insulated tank, the vapor space temperature and the liquid surface temperature are both assumed to be equal to the liquid bulk temperature. Thus the vapor temperature range ΔT_V should be calculated from the actual range of liquid bulk temperature in the tank, rather than using Equation 1-6 or Equation 1-7. The actual range of liquid bulk temperature may be determined from direct measurements or estimated from process knowledge.

$$\Delta T_V = T_{BX} - T_{BN} \quad (8-1)$$

where:

T_{BX} = typical maximum liquid bulk temperature in the heating cycle, °R

T_{BN} = typical minimum liquid bulk temperature in the heating cycle, °R

The vapor pressure range ΔP_V is calculated from Equation 1-9.

$$\Delta P_V = P_{VX} - P_{VN} \quad (1-9)$$

where:

P_{VX} and P_{VN} are the vapor pressures at T_{LX} and T_{LN} , respectively, and:

$T_{LX} = T_{BX}$

$T_{LN} = T_{BN}$

Similarly, the average liquid surface temperature T_{LA} should be taken as being equal to actual average liquid bulk temperature T_B , rather than being calculated from Equation 1-29 or Equation 1-30.

$$T_{LA} = T_B \quad (8-2)$$

7.1.4 Speciation Methodology²²

In some cases it may be important to know the annual emission rate for a component (e. g., HAP) of a stored liquid mixture. There are two basic approaches that can be used to estimate emissions for a single component of a stored liquid mixture. One approach involves calculating the total losses based upon the known physical properties of the mixture (i. e., gasoline) in the vapor phase and then determining the individual component losses by multiplying the total loss by the vapor weight fraction of the desired component. However, the weight fraction of a given component in the vapor phase will vary with temperature, and thus this approach is valid only at the temperature for which the vapor weight fraction was determined.

The second approach is similar to the first approach except that the mixture properties in the vapor phase are unknown; therefore, the vapor phase mixture properties are first determined based on the composition of the liquid mixture. This involves application of Raoult's Law, which assumes ideal behavior on the part of each of the components in the mixture. An assumption of ideal behavior has been found to be reasonable for most hydrocarbon mixtures. The two approaches outlined above are illustrated in Case 1 below.

An assumption of ideal behavior may not be appropriate for aqueous mixtures or mixtures containing alcohols. The molecules of water and alcohols are polar, meaning that the individual molecules of these substances have an attraction for one another, resulting in behavior that deviates significantly from ideal assumptions. An illustration of speciation for a dilute aqueous mixture is presented in Case 2 below. Tanks containing aqueous mixtures in which phase separation has occurred, resulting in a free layer of oil or other volatile materials floating on top of the water, should have emissions estimated on the basis of the properties of the free top layer.

Raoult's Law is also not applied to speciate working (withdrawal) loss from floating roof tanks. The application of Raoult's Law outlined in this section assumes the fraction of the available liquid that evaporates is very small compared to the total mass of liquid available, and thus the properties of the remaining liquid can be assumed to be unaffected by the loss of the evaporated fraction. Floating roof withdrawal loss, however, involves evaporation of a thin film of liquid from the wetted tank shell as the liquid level descends. It is typically assumed that the entire film of liquid evaporates, and thus relative fractions of individual components in the vapors would be the same as for the liquid. It would be appropriate, however, to adjust this assumption to recognize that substances which are non-subliming solids at the storage temperature (such as most polycyclic aromatic hydrocarbons at ambient temperatures) are not going to evaporate.

Case 1 – If the physical properties of the mixture are known (P_{VA} , M_V , M_L and W_L), the total losses from the tank should be estimated using the procedures described previously for the particular tank type. The component losses are then determined from either Equation 40-1 or 40-2. For fixed roof tanks, the emission rate for each individual component can be estimated by:

$$L_{T_i} = (Z_{V_i})(L_T) \quad (40-1)$$

where:

- L_{T_i} = emission rate of component i, lb/yr
- Z_{V_i} = weight fraction of component i in the vapor, lb/lb
- L_T = total losses, lb/yr

For floating roof tanks, the emission rate for each individual component can be estimated by:

$$L_{T_i} = (Z_{V_i})(L_R + L_F + L_D) + (Z_{L_i})(L_W) \quad (40-2)$$

where:

- L_{T_i} = emission rate of component i, lb/yr
- Z_{V_i} = weight fraction of component i in the vapor, lb/lb
- L_R = rim seal losses, lb/yr
- L_F = deck fitting losses, lb/yr
- L_D = deck seam losses, lb/yr
- Z_{L_i} = weight fraction of component i in the liquid, lb/lb
- L_W = working (withdrawal) losses, lb/yr

If Equation 40-1 is used in place of Equation 40-2 for floating roof tanks, the value obtained will be approximately the same value as that achieved with Equation 40-2 because withdrawal losses are typically minimal for floating roof tanks.

In order to use Equations 40-1 and 40-2, the weight fraction of the desired component in the liquid and vapor phase is needed. The liquid weight fraction of the desired component is typically known or can be readily calculated or determined by analysis for most mixtures. In order to calculate the weight fraction in the vapor phase, Raoult's Law must first be used to determine the partial pressure of the component. The partial pressure of the component can then be divided by the total vapor pressure of the mixture to determine the mole fraction of the component in the vapor phase. Raoult's Law states that the mole fraction of the component in the liquid (x_i) multiplied by the vapor pressure of the pure component (at the average daily liquid surface temperature) (P) is equal to the partial pressure (P_i) of that component:

$$P_i = (P)(x_i) \quad (40-3)$$

where:

- P_i = partial pressure of component i, psia
- P = vapor pressure of pure component i at the average daily liquid surface temperature, psia
- x_i = liquid mole fraction, lb-mole/lb-mole

The vapor pressure of each component can be calculated from Antoine's equation or found in standard references, as shown in Section 7.1.3.1. In order to use Equation 40-3, the liquid mole fraction must be determined from the liquid weight fraction by:

$$x_i = \left(\frac{Z_{Li} M_L}{M_i} \right) \quad (40-4)$$

where:

- x_i = liquid mole fraction of component i, lb-mole/lb-mole
- Z_{Li} = weight fraction of component i in the liquid, lb/lb
- M_L = molecular weight of liquid stock, lb/lb-mole
- M_i = molecular weight of component i, lb/lb-mole

The liquid mole fraction and the vapor pressure of the component at the average daily liquid surface temperature can then be substituted into Equation 40-3 to obtain the partial pressure of the component. The vapor mole fraction of the component can be determined from the following equation:

$$y_i = \frac{P_i}{P_{VA}} \quad (40-5)$$

where:

- y_i = vapor mole fraction of component i, lb-mole/lb-mole
- P_i = partial pressure of component i, psia
- P_{VA} = total vapor pressure of liquid mixture, psia

The weight fractions in the vapor phase are calculated from the mole fractions in the vapor phase.

$$Z_{Vi} = \frac{y_i M_i}{M_V} \quad (40-6)$$

where:

- Z_{Vi} = vapor weight fraction of component i, lb/lb
- y_i = vapor mole fraction of component i, lb-mole/lb-mole
- M_i = molecular weight of component i, lb/lb-mole
- M_V = molecular weight of vapor stock, lb/lb-mole

The liquid and vapor weight fractions of each desired component and the total losses can be substituted into either Equations 40-1 or 40-2 to estimate the individual component losses.

Case 2 –For special cases, such as wastewater, where the liquid mixture is a dilute aqueous solution, Henry's Law should be used instead of Raoult's Law in calculating total losses. Henry's Law states that the mole fraction of the component in the liquid phase multiplied by the Henry's Law

constant for the component in the mixture is equal to the partial pressure (P_i) for that component. For wastewater, Henry's Law constants are typically provided in the form of $\text{atm}\cdot\text{m}^3/\text{g-mole}$.

Therefore, the appropriate form of Henry's Law equation is:

$$P_i = (H_A) (C_i) \quad (40-7)$$

where:

- P_i = partial pressure of component i, atm
- H_A = Henry's Law constant for component i, $\text{atm}\cdot\text{m}^3/\text{g-mole}$
- C_i = concentration of component i in the wastewater, $\text{g-mole}/\text{m}^3$; see Note

Section 4.3 of AP-42 presents Henry's Law constants for selected organic liquids in water at 25 °C. The partial pressure calculated from Equation 40-7 will need to be converted from atmospheres to psia (1 atm = 14.7 psia).

Note: Typically wastewater concentrations are given in mg/liter, which is equivalent to g/m^3 . To convert the concentrations to $\text{g-mole}/\text{m}^3$ divide the concentration by the molecular weight of the component.

The total vapor pressure of the mixture can be calculated from the sum of the partial pressures:

$$P_{VA} = \sum P_i \quad (40-8)$$

where:

- P_{VA} = vapor pressure at average daily liquid surface temperature, psia
- P_i = partial pressure of component i, psia

This procedure can be used to determine the vapor pressure at any temperature. After computing the total vapor pressure, the mole fractions in the vapor phase are calculated using Equation 40-5. The vapor mole fractions are used to calculate the molecular weight of the vapor, M_v . The molecular weight of the vapor can be calculated by:

$$M_v = \sum M_i y_i \quad (40-9)$$

where:

- M_v = molecular weight of the vapor, lb/lb-mole
- M_i = molecular weight of component i, lb/lb-mole
- y_i = vapor mole fraction of component i, lb-mole/lb-mole

Another variable that may need to be calculated before estimating the total losses, if it is not available in a standard reference, is the density of the liquid, W_L . If the density of the liquid is unknown, it can be estimated based on the liquid weight fractions of each component (see Section 7.1.5, Example 3).

All of the mixture properties are now known (P_{VA} , M_V , and W_L). These values can now be used with the emission estimation procedures outlined in Section 7.1.3 to estimate total losses. After calculating the total losses, the component losses can be calculated by using either Equations 40-1 or 40-2. Prior to calculating component losses, Equation 40-6 must be used to determine the vapor weight fractions of each component.

7.1.5 Source Classification Codes

- 2501000000 - Storage and Transport, Petroleum and Petroleum Product Storage, All Storage Types: Breathing Loss, Total: All Products
- 2501000030 - Storage and Transport, Petroleum and Petroleum Product Storage, All Storage Types: Breathing Loss, Crude Oil
- 2501000060 - Storage and Transport, Petroleum and Petroleum Product Storage, All Storage Types: Breathing Loss, Residual Oil
- 2501000090 - Storage and Transport, Petroleum and Petroleum Product Storage, All Storage Types: Breathing Loss, Distillate Oil
- 2501000120 - Storage and Transport, Petroleum and Petroleum Product Storage, All Storage Types: Breathing Loss, Gasoline
- 2501000150 - Storage and Transport, Petroleum and Petroleum Product Storage, All Storage Types: Breathing Loss, Jet Naphtha
- 2501000180 - Storage and Transport, Petroleum and Petroleum Product Storage, All Storage Types: Breathing Loss, Kerosene
- 2501000900 - Storage and Transport, Petroleum and Petroleum Product Storage, All Storage Types: Breathing Loss, Tank Cleaning
- 2501010000 - Storage and Transport, Petroleum and Petroleum Product Storage, Commercial/Industrial: Breathing Loss, Total: All Products
- 2501010030 - Storage and Transport, Petroleum and Petroleum Product Storage, Commercial/Industrial: Breathing Loss, Crude Oil
- 2501010060 - Storage and Transport, Petroleum and Petroleum Product Storage, Commercial/Industrial: Breathing Loss, Residual Oil
- 2501010090 - Storage and Transport, Petroleum and Petroleum Product Storage, Commercial/Industrial: Breathing Loss, Distillate Oil
- 2501010120 - Storage and Transport, Petroleum and Petroleum Product Storage, Commercial/Industrial: Breathing Loss, Gasoline
- 2501010150 - Storage and Transport, Petroleum and Petroleum Product Storage, Commercial/Industrial: Breathing Loss, Jet Naphtha

- 2501010180 - Storage and Transport, Petroleum and Petroleum Product Storage, Commercial/Industrial: Breathing Loss, Kerosene
- 2501010900 - Storage and Transport, Petroleum and Petroleum Product Storage, Commercial/Industrial: Breathing Loss, Tank Cleaning
- 2501011011 - Storage and Transport, Petroleum and Petroleum Product Storage, Residential Portable Gas Cans, Permeation
- 2501011012 - Storage and Transport, Petroleum and Petroleum Product Storage, Residential Portable Gas Cans, Evaporation (includes Diurnal losses)
- 2501011013 - Storage and Transport, Petroleum and Petroleum Product Storage, Residential Portable Gas Cans, Spillage During Transport
- 2501011014 - Storage and Transport, Petroleum and Petroleum Product Storage, Residential Portable Gas Cans, Refilling at the Pump - Vapor Displacement
- 2501011015 - Storage and Transport, Petroleum and Petroleum Product Storage, Residential Portable Gas Cans, Refilling at the Pump – Spillage
- 2501012011 - Storage and Transport, Petroleum and Petroleum Product Storage, Commercial Portable Gas Cans, Permeation
- 2501012012 - Storage and Transport, Petroleum and Petroleum Product Storage, Commercial Portable Gas Cans, Evaporation (includes Diurnal losses)
- 2501012013 - Storage and Transport, Petroleum and Petroleum Product Storage, Commercial Portable Gas Cans, Spillage During Transport
- 2501012014 - Storage and Transport, Petroleum and Petroleum Product Storage, Commercial Portable Gas Cans, Refilling at the Pump - Vapor Displacement
- 2501012015 - Storage and Transport, Petroleum and Petroleum Product Storage, Commercial Portable Gas Cans, Refilling at the Pump – Spillage
- 2501013010 - Storage and Transport, Petroleum and Petroleum Product Storage, Residential/Commercial Portable Gas Cans, Total: All Types
- 2501050000 - Storage and Transport, Petroleum and Petroleum Product Storage, Bulk Terminals: All Evaporative Losses, Total: All Products
- 2501050030 - Storage and Transport, Petroleum and Petroleum Product Storage, Bulk Terminals: All Evaporative Losses, Crude Oil
- 2501050060 - Storage and Transport, Petroleum and Petroleum Product Storage, Bulk Terminals: All Evaporative Losses, Residual Oil
- 2501050090 - Storage and Transport, Petroleum and Petroleum Product Storage, Bulk Terminals: All Evaporative Losses, Distillate Oil
- 2501050120 - Storage and Transport, Petroleum and Petroleum Product Storage, Bulk Terminals: All Evaporative Losses, Gasoline

- 2501050150 - Storage and Transport, Petroleum and Petroleum Product Storage, Bulk Terminals: All Evaporative Losses, Jet Naphtha
- 2501050180 - Storage and Transport, Petroleum and Petroleum Product Storage, Bulk Terminals: All Evaporative Losses, Kerosene
- 2501050900 - Storage and Transport, Petroleum and Petroleum Product Storage, Bulk Terminals: All Evaporative Losses, Tank Cleaning
- 2501055120 - Storage and Transport, Petroleum and Petroleum Product Storage, Bulk Plants: All Evaporative Losses, Gasoline
- 2501059120 - Storage and Transport, Petroleum and Petroleum Product Storage, Bulk Plants/Terminals: All Evaporative Losses, Gasoline
- 2501060050 - Storage and Transport, Petroleum and Petroleum Product Storage, Gasoline Service Stations, Stage 1: Total
- 2501060051 - Storage and Transport, Petroleum and Petroleum Product Storage, Gasoline Service Stations, Stage 1: Submerged Filling
- 2501060052 - Storage and Transport, Petroleum and Petroleum Product Storage, Gasoline Service Stations, Stage 1: Splash Filling
- 2501060053 - Storage and Transport, Petroleum and Petroleum Product Storage, Gasoline Service Stations, Stage 1: Balanced Submerged Filling
- 2501060201 - Storage and Transport, Petroleum and Petroleum Product Storage, Gasoline Service Stations, Underground Tank: Breathing and Emptying
- 2501070050 - Storage and Transport, Petroleum and Petroleum Product Storage, Diesel Service Stations, Stage 1: Total
- 2501070051 - Storage and Transport, Petroleum and Petroleum Product Storage, Diesel Service Stations, Stage 1: Submerged Filling
- 2501070052 - Storage and Transport, Petroleum and Petroleum Product Storage, Diesel Service Stations, Stage 1: Splash Filling
- 2501070053 - Storage and Transport, Petroleum and Petroleum Product Storage, Diesel Service Stations, Stage 1: Balanced Submerged Filling
- 2501070201 - Storage and Transport, Petroleum and Petroleum Product Storage, Diesel Service Stations, Underground Tank: Breathing and Emptying
- 2501080050 - Storage and Transport, Petroleum and Petroleum Product Storage, Airports : Aviation Gasoline, Stage 1: Total
- 2501080100 - Storage and Transport, Petroleum and Petroleum Product Storage, Airports : Aviation Gasoline, Stage 2: Total
- 2501080201 - Storage and Transport, Petroleum and Petroleum Product Storage, Airports : Aviation Gasoline, Underground Tank: Breathing and Emptying

- 2501995000 - Storage and Transport, Petroleum and Petroleum Product Storage, All Storage Types: Working Loss, Total: All Products
- 2501995030 - Storage and Transport, Petroleum and Petroleum Product Storage, All Storage Types: Working Loss, Crude Oil
- 2501995060 - Storage and Transport, Petroleum and Petroleum Product Storage, All Storage Types: Working Loss, Residual Oil
- 2501995090 - Storage and Transport, Petroleum and Petroleum Product Storage, All Storage Types: Working Loss, Distillate Oil
- 2501995120 - Storage and Transport, Petroleum and Petroleum Product Storage, All Storage Types: Working Loss, Gasoline
- 2501995150 - Storage and Transport, Petroleum and Petroleum Product Storage, All Storage Types: Working Loss, Jet Naphtha
- 2501995180 - Storage and Transport, Petroleum and Petroleum Product Storage, All Storage Types: Working Loss, Kerosene
- 2505000000 - Storage and Transport, Petroleum and Petroleum Product Transport, All Transport Types, Total: All Products
- 2505000030 - Storage and Transport, Petroleum and Petroleum Product Transport, All Transport Types, Crude Oil
- 2505000060 - Storage and Transport, Petroleum and Petroleum Product Transport, All Transport Types, Residual Oil
- 2505000090 - Storage and Transport, Petroleum and Petroleum Product Transport, All Transport Types, Distillate Oil
- 2505000120 - Storage and Transport, Petroleum and Petroleum Product Transport, All Transport Types, Gasoline
- 2505000150 - Storage and Transport, Petroleum and Petroleum Product Transport, All Transport Types, Jet Naphtha
- 2505000180 - Storage and Transport, Petroleum and Petroleum Product Transport, All Transport Types, Kerosene
- 2505000900 - Storage and Transport, Petroleum and Petroleum Product Transport, All Transport Types, Tank Cleaning
- 2505010000 - Storage and Transport, Petroleum and Petroleum Product Transport, Rail Tank Car, Total: All Products
- 2505010030 - Storage and Transport, Petroleum and Petroleum Product Transport, Rail Tank Car, Crude Oil
- 2505010060 - Storage and Transport, Petroleum and Petroleum Product Transport, Rail Tank Car, Residual Oil

- 2505010090 - Storage and Transport, Petroleum and Petroleum Product Transport, Rail Tank Car, Distillate Oil
- 2505010120 - Storage and Transport, Petroleum and Petroleum Product Transport, Rail Tank Car, Gasoline
- 2505010150 - Storage and Transport, Petroleum and Petroleum Product Transport, Rail Tank Car, Jet Naphtha
- 2505010180 - Storage and Transport, Petroleum and Petroleum Product Transport, Rail Tank Car, Kerosene
- 2505010900 - Storage and Transport, Petroleum and Petroleum Product Transport, Rail Tank Car, Tank Cleaning
- 2505020000 - Storage and Transport, Petroleum and Petroleum Product Transport, Marine Vessel, Total: All Products
- 2505020030 - Storage and Transport, Petroleum and Petroleum Product Transport, Marine Vessel, Crude Oil
- 2505020041 - Storage and Transport, Petroleum and Petroleum Product Transport, Marine Vessel, Lube Oil-Barge
- 2505020060 - Storage and Transport, Petroleum and Petroleum Product Transport, Marine Vessel, Residual Oil
- 2505020090 - Storage and Transport, Petroleum and Petroleum Product Transport, Marine Vessel, Distillate Oil
- 2505020091 - Storage and Transport, Petroleum and Petroleum Product Transport, Marine Vessel, Distillate Oil-#1 Diesel-Barge
- 2505020092 - Storage and Transport, Petroleum and Petroleum Product Transport, Marine Vessel, Distillate Oil-#2 Diesel-Barge
- 2505020093 - Storage and Transport, Petroleum and Petroleum Product Transport, Marine Vessel, Distillate Oil-Marine Diesel-Barge
- 2505020120 - Storage and Transport, Petroleum and Petroleum Product Transport, Marine Vessel, Gasoline
- 2505020121 - Storage and Transport, Petroleum and Petroleum Product Transport, Marine Vessel, Gasoline – Barge
- 2505020150 - Storage and Transport, Petroleum and Petroleum Product Transport, Marine Vessel, Jet Naphtha
- 2505020180 - Storage and Transport, Petroleum and Petroleum Product Transport, Marine Vessel, Kerosene
- 2505020182 - Storage and Transport, Petroleum and Petroleum Product Transport, Marine Vessel, Jet Kerosene-Barge

- 2505020900 - Storage and Transport, Petroleum and Petroleum Product Transport, Marine Vessel, Tank Cleaning
- 2505030000 - Storage and Transport, Petroleum and Petroleum Product Transport, Truck, Total: All Products
- 2505030030 - Storage and Transport, Petroleum and Petroleum Product Transport, Truck, Crude Oil
- 2505030060 - Storage and Transport, Petroleum and Petroleum Product Transport, Truck, Residual Oil
- 2505030090 - Storage and Transport, Petroleum and Petroleum Product Transport, Truck, Distillate Oil
- 2505030120 - Storage and Transport, Petroleum and Petroleum Product Transport, Truck, Gasoline
- 2505030150 - Storage and Transport, Petroleum and Petroleum Product Transport, Truck, Jet Naphtha
- 2505030180 - Storage and Transport, Petroleum and Petroleum Product Transport, Truck, Kerosene
- 2505030900 - Storage and Transport, Petroleum and Petroleum Product Transport, Truck, Tank Cleaning
- 2505040000 - Storage and Transport, Petroleum and Petroleum Product Transport, Pipeline, Total: All Products
- 2505040030 - Storage and Transport, Petroleum and Petroleum Product Transport, Pipeline, Crude Oil
- 2505040060 - Storage and Transport, Petroleum and Petroleum Product Transport, Pipeline, Residual Oil
- 2505040090 - Storage and Transport, Petroleum and Petroleum Product Transport, Pipeline, Distillate Oil
- 2505040120 - Storage and Transport, Petroleum and Petroleum Product Transport, Pipeline, Gasoline
- 2505040150 - Storage and Transport, Petroleum and Petroleum Product Transport, Pipeline, Jet Naphtha
- 2505040180 - Storage and Transport, Petroleum and Petroleum Product Transport, Pipeline, Kerosene
- 2510000000 - Storage and Transport, Organic Chemical Storage, All Storage Types: Breathing Loss, Total: All Products
- 2510010000 - Storage and Transport, Organic Chemical Storage, Commercial/Industrial: Breathing Loss, Total: All Products

- 2510050000 - Storage and Transport, Organic Chemical Storage, Bulk Stations/Terminals: Breathing Loss, Total: All Products
- 2510995000 - Storage and Transport, Organic Chemical Storage, All Storage Types: Working Loss, Total: All Products

7.1.6 Summary of Major Updates

March 2020

- Added clarifying language and made minor corrections and consistency changes to text and to figure descriptions
- 7.1.1.1 - Added a new section titled Scope, to provide an overview of the chapter
- 7.1.3.2 Separated the calculation of standing loss from the calculation of working loss for floating-roof tanks, rather than having the two intertwined
- Edited variable labels for consistency and updated Table 7.1-1 accordingly

October 2024

- Added clarifying language and made minor corrections and consistency changes to text and to figure descriptions
- Added Source Classification Codes
- Added parameter definitions below equations where missing
- Added discussion of TANKS 5.1
- Corrected Equation 1-16 for rectangular tanks and corrected Equation 1-17 for square tanks
- Added information for Dibromoethane (1,2) to Table 7.1-3
- Added information for Tetraethyllead to Table 7.1-3

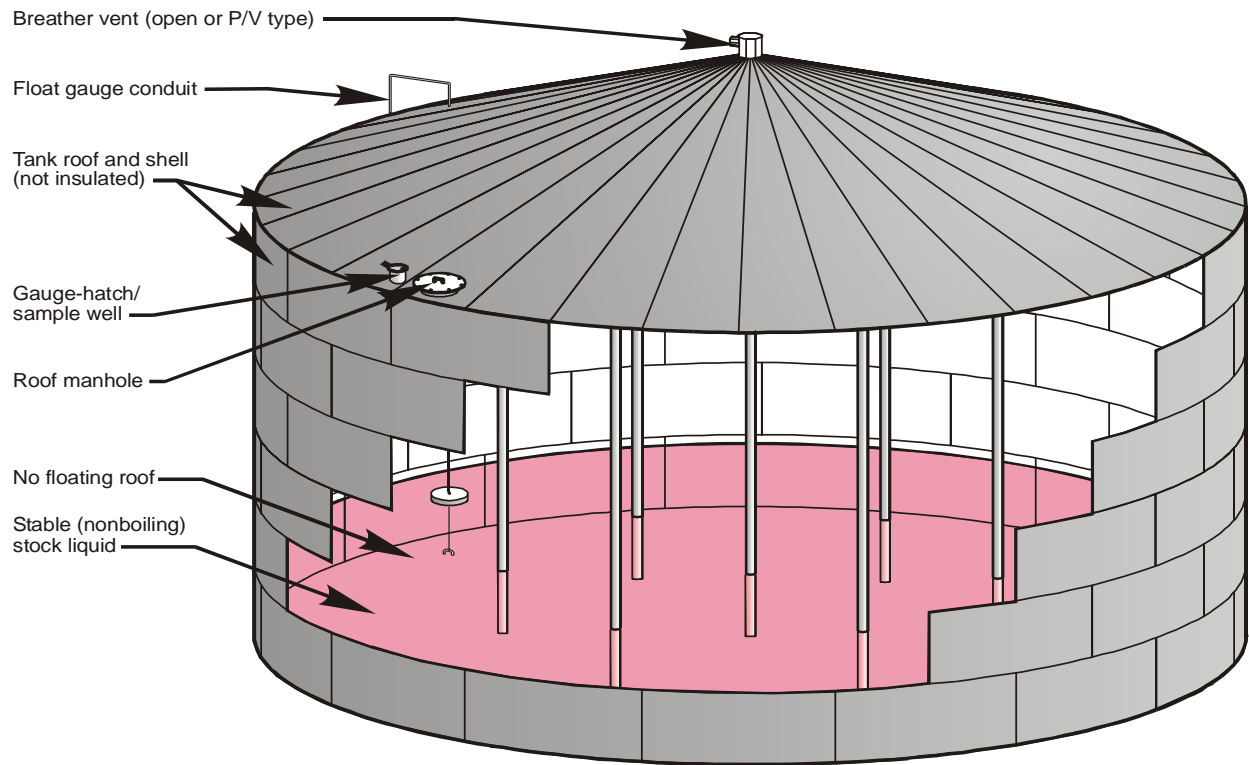

Figure 7.1-1. Typical fixed-roof tank .²⁰

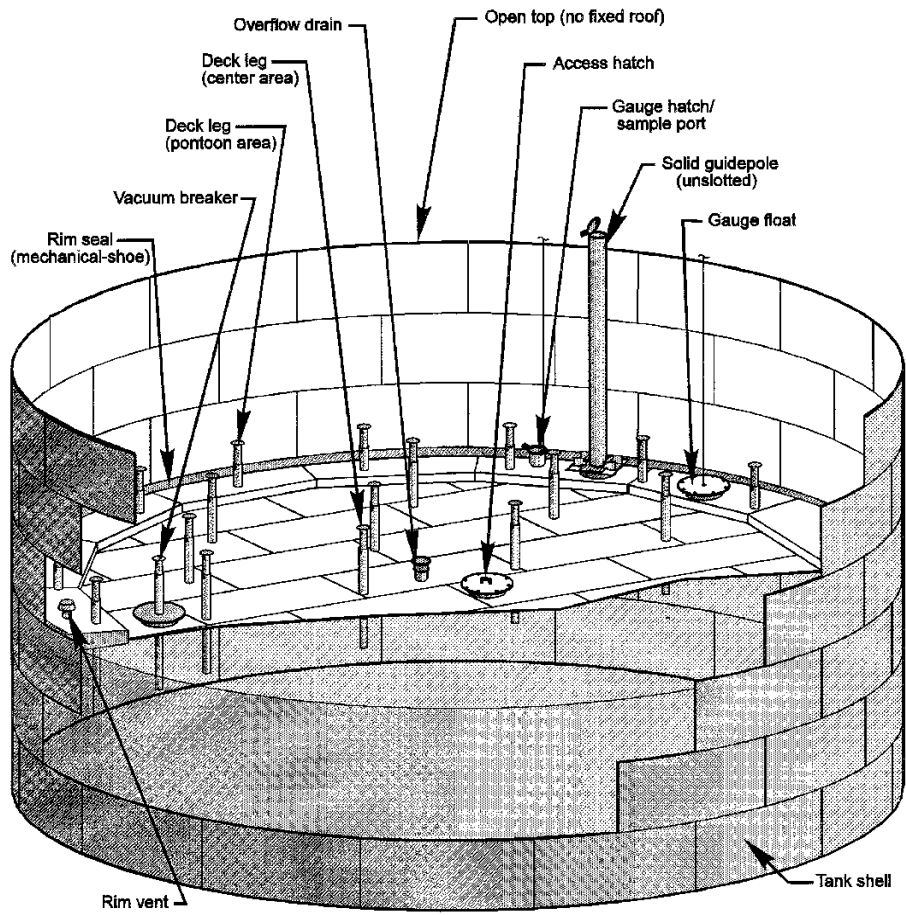

Figure 7.1-2. External floating roof tank (pontoon type) .²⁰

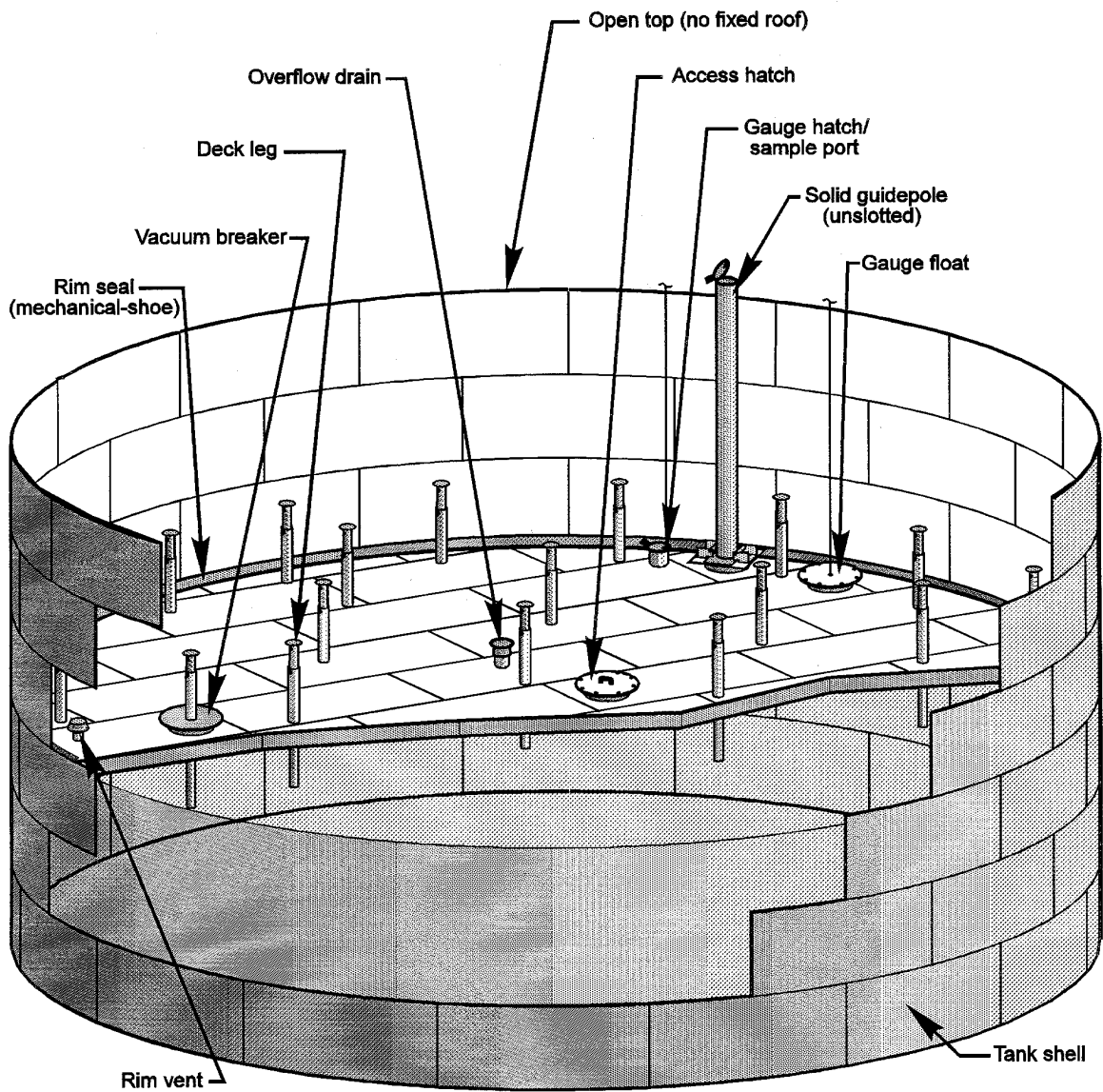

Figure 7.1-3. External floating roof tank (double deck) .²⁰

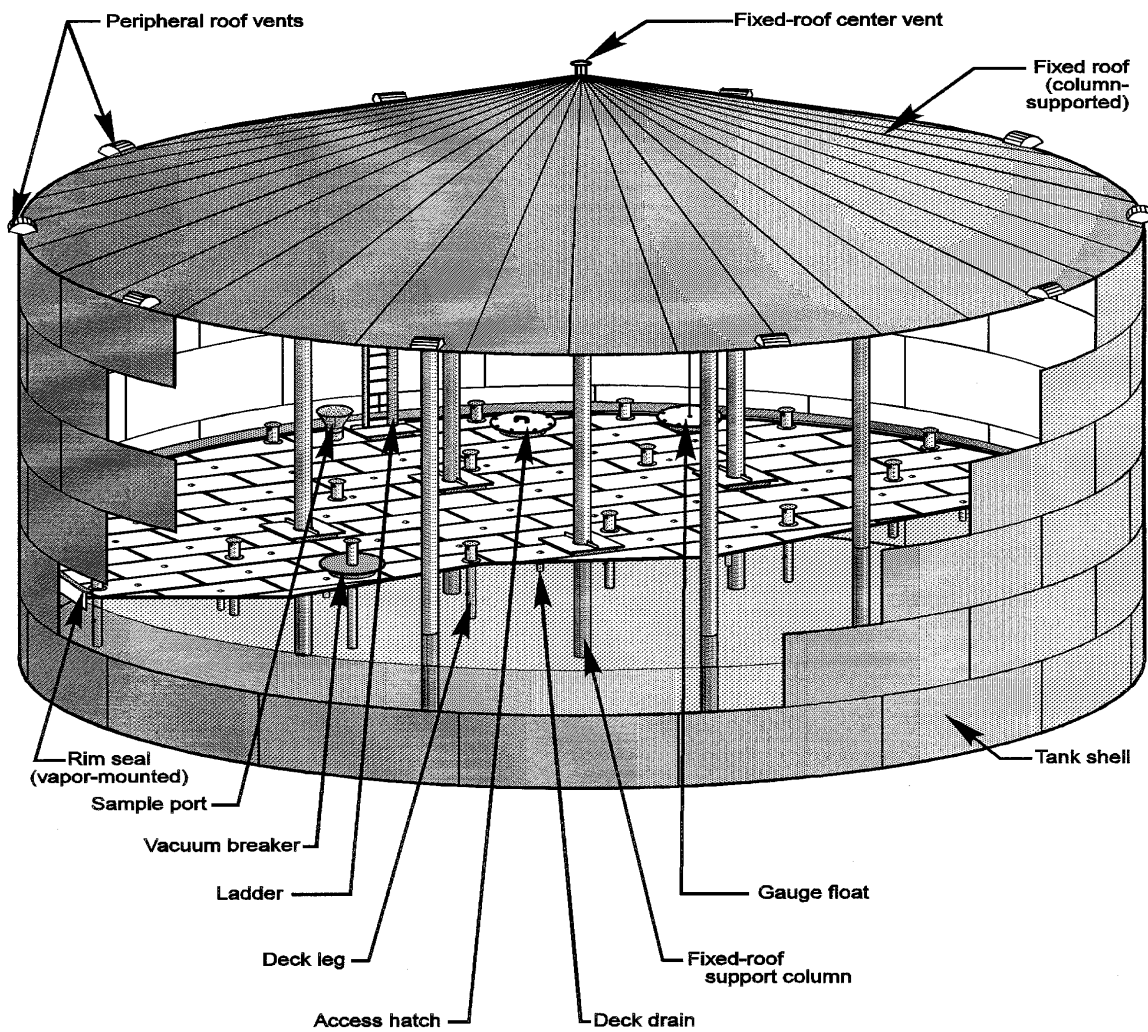

Figure 7.1-4. Internal floating roof tank. ²⁰

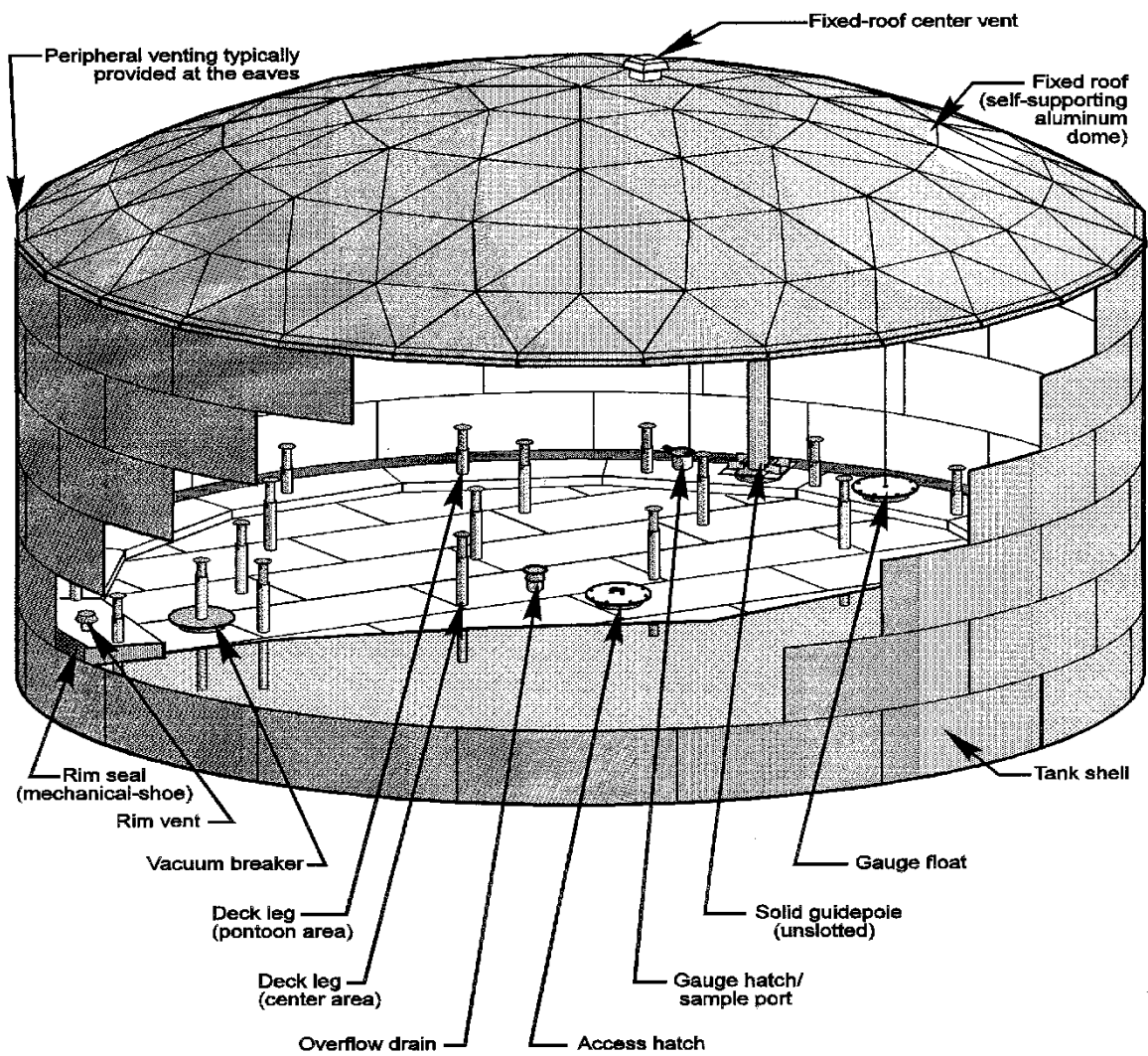

Figure 7.1-5. Domed external floating roof tank. ²⁰

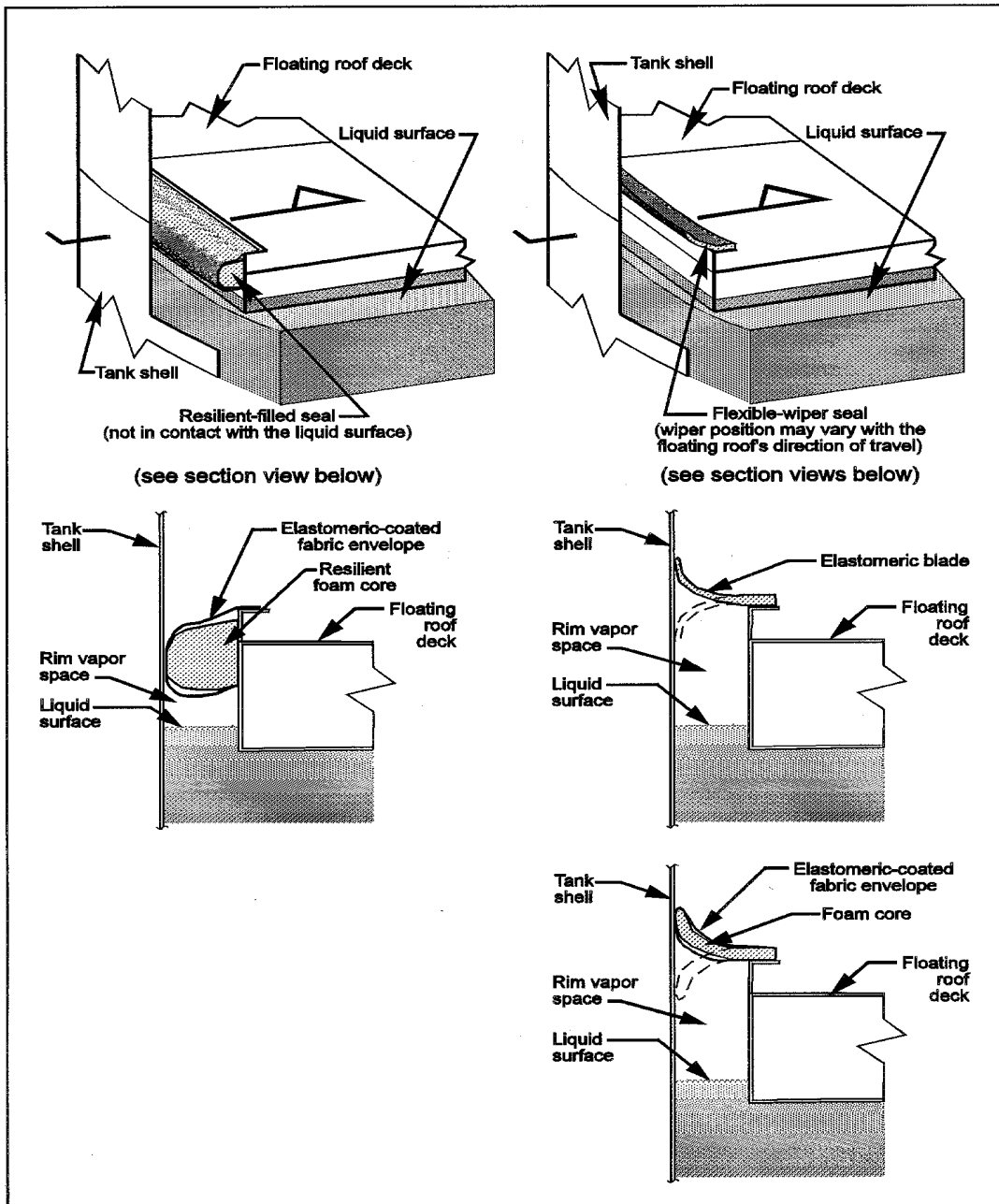

Figure 7.1-6. Vapor-mounted primary seals.²⁰

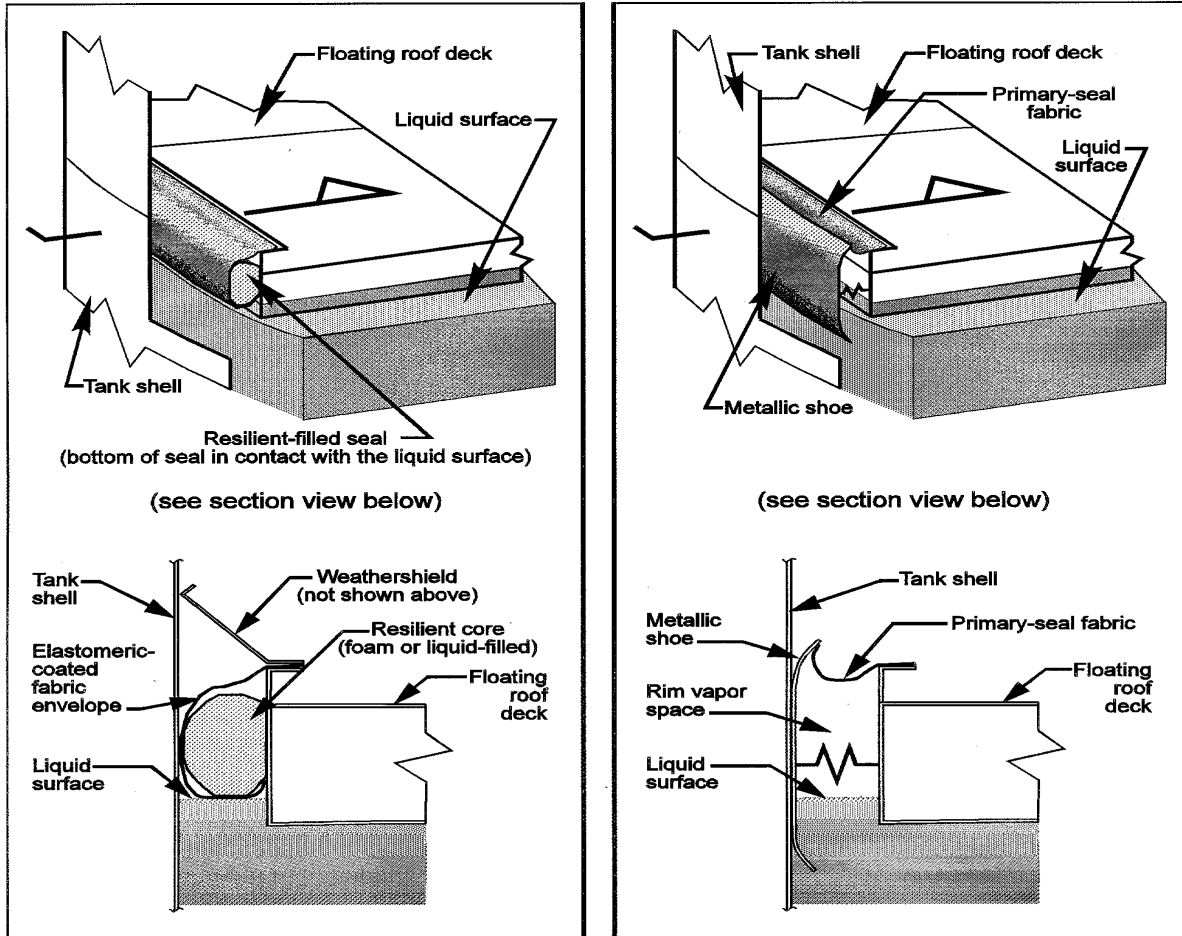

Figure 7.1-7. Liquid-mounted and mechanical shoe primary seals.²⁰

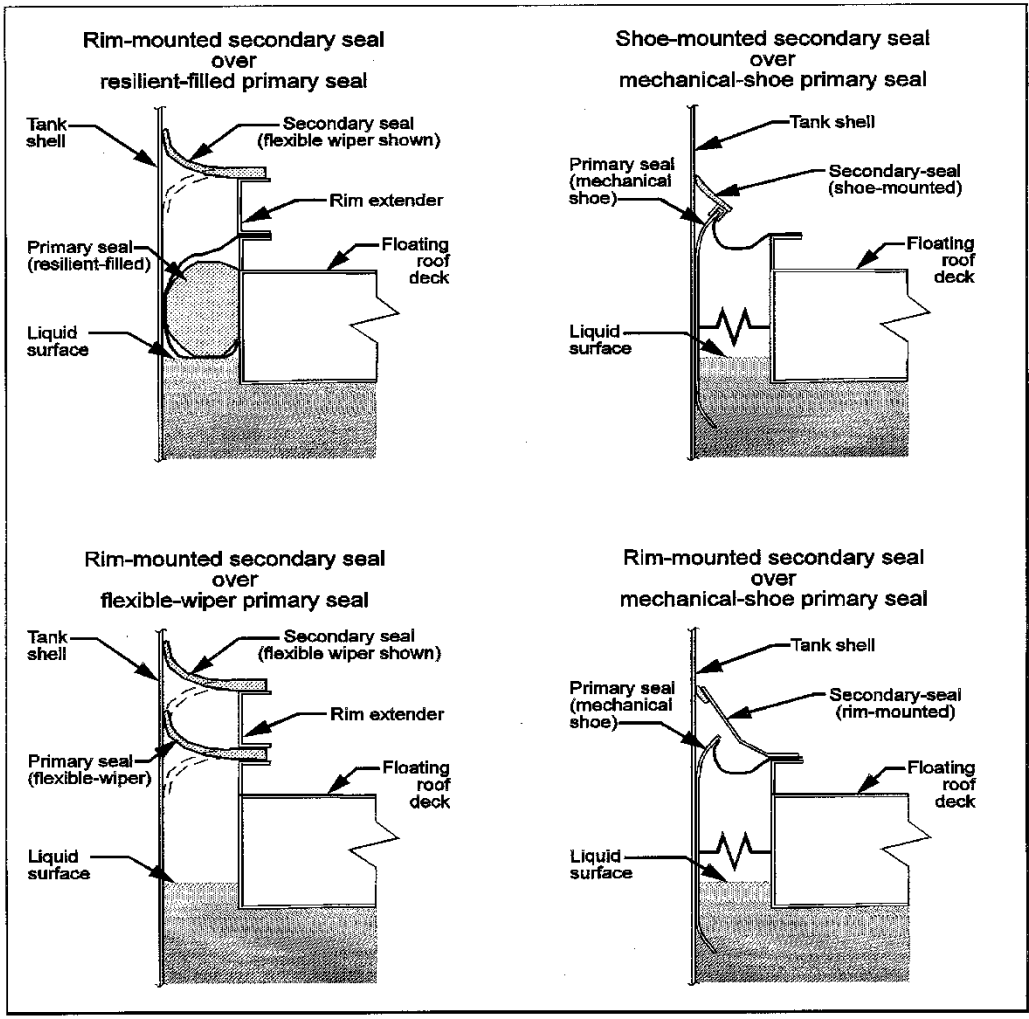
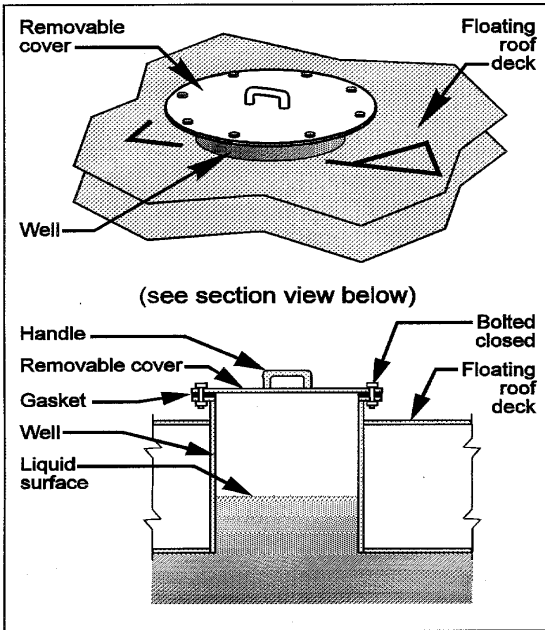
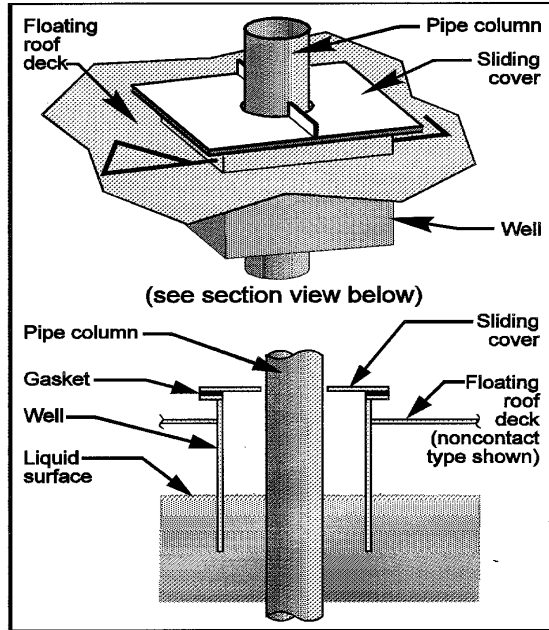

Figure 7.1-8. Secondary rim seals.²⁰



Access Hatch



Fixed-Roof Support Column

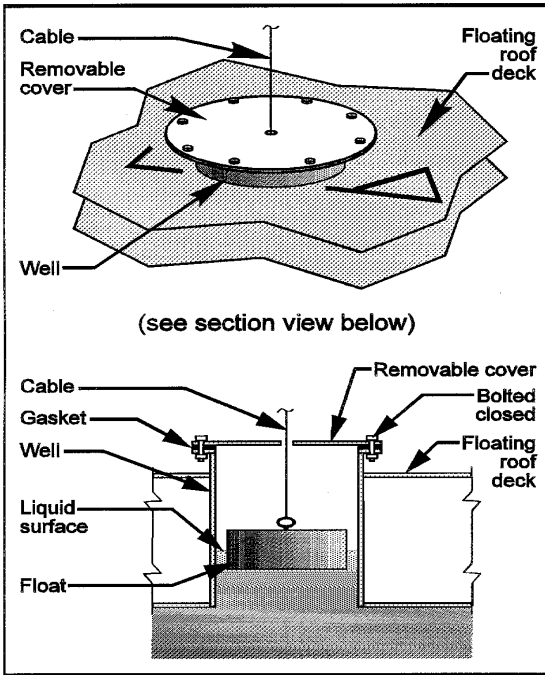

Gauge float

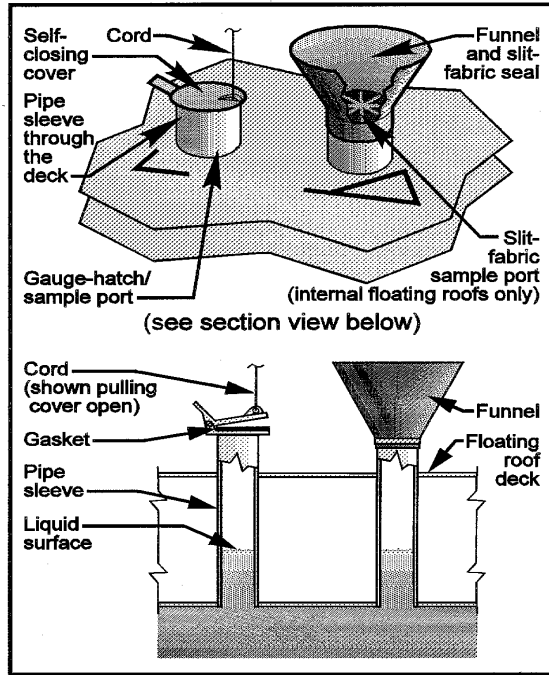

Sample Ports

Figure 7.1-9. Deck fittings for floating roof tanks.²⁰

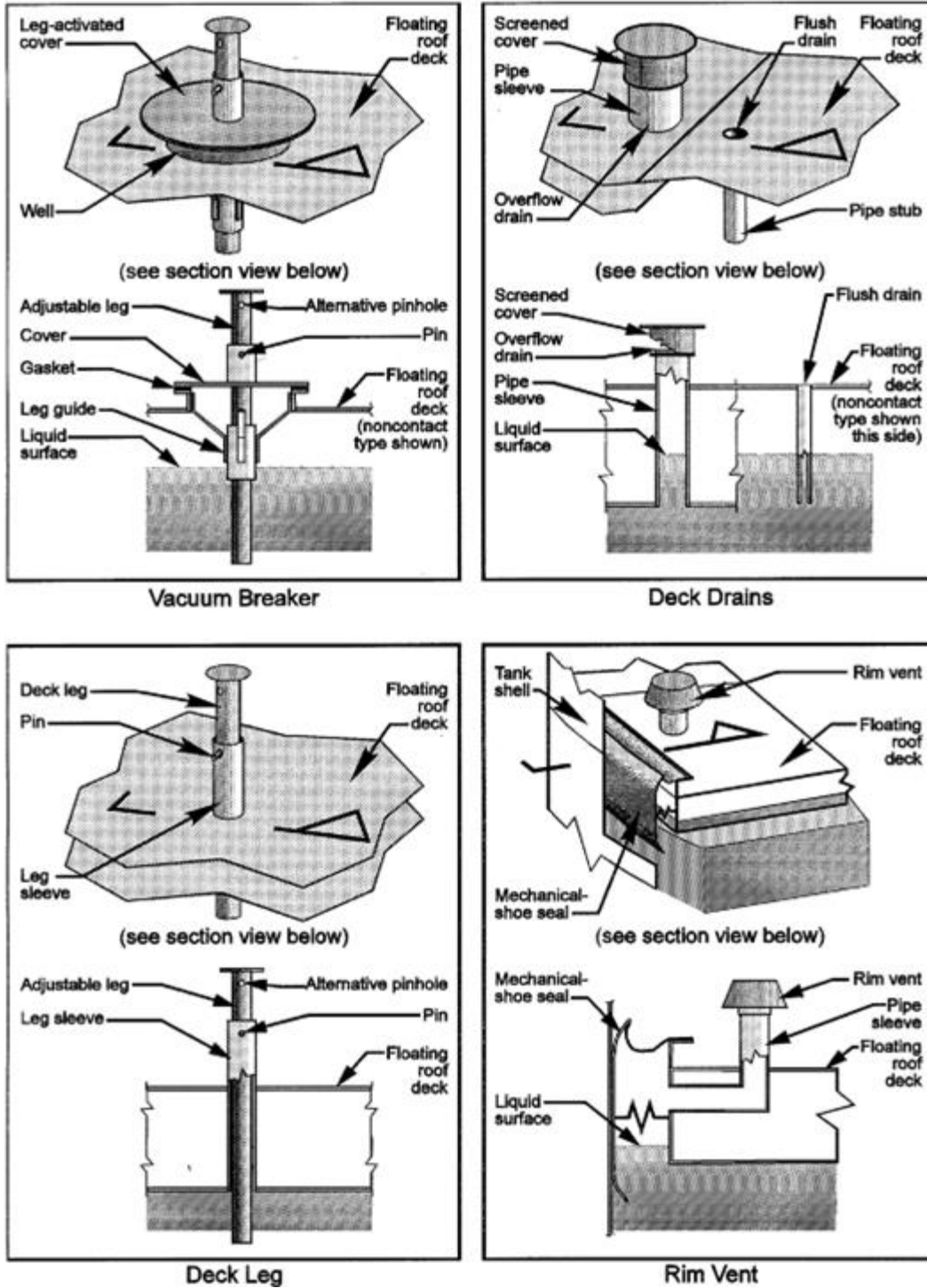
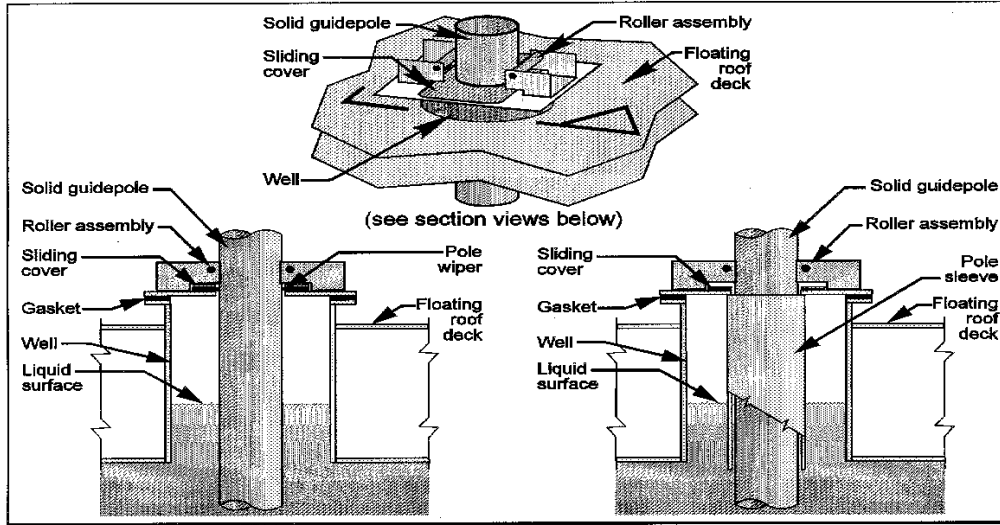
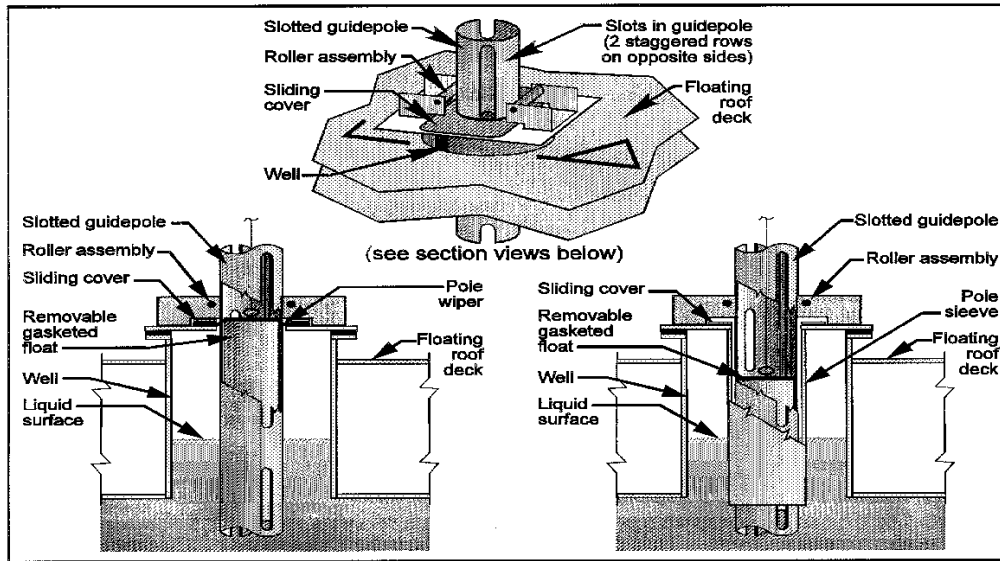

Figure 7.1-10. Deck fittings for floating roof tanks. ²⁰



Unslotted (solid) Guidepole



Slotted (perforated) Guidepole

Figure 7.1-11. Slotted and unslotted guidepoles.²⁰

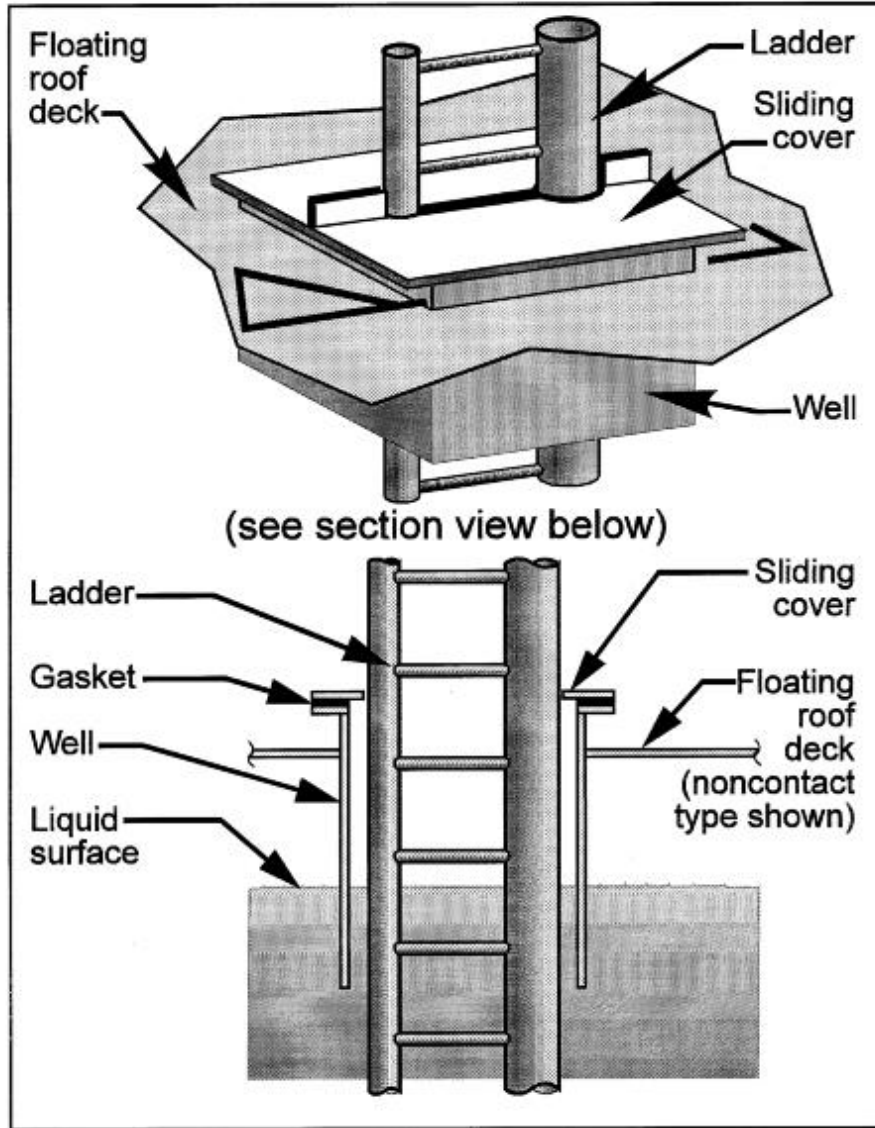

Figure 7.1-12. Ladder well. ²⁰

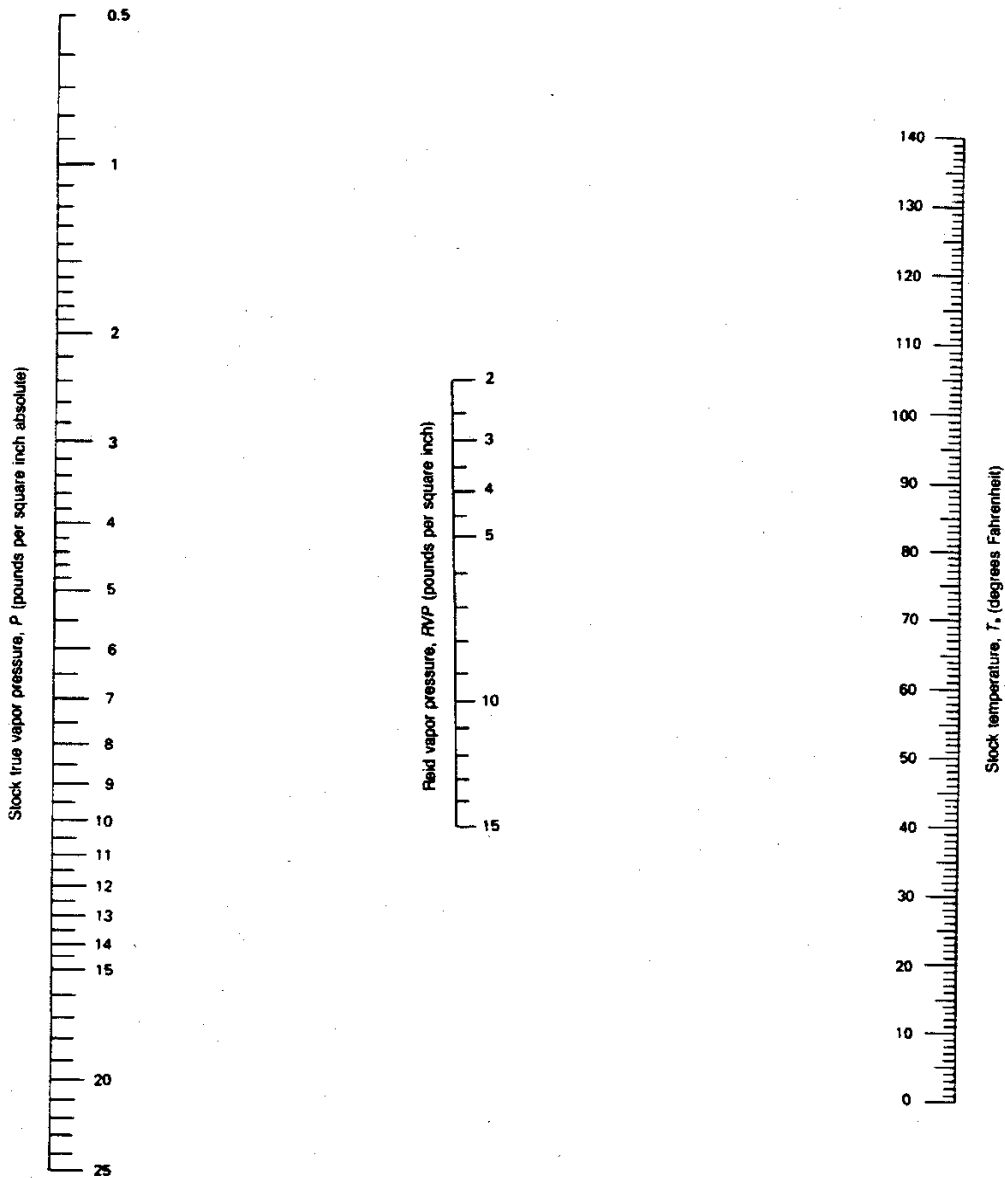

Figure 7.1-13a. True vapor pressure of crude oils with Reid vapor pressures of 2 to 15 psi. ⁴

Note 1. The “stock temperature, T ” in Figure 7.1-13a shall be taken as the liquid surface temperature, T_{LA} .

Note 2. The nomograph in Figure 7.1-13a and the correlation equation in Figure 7.1-13b for predicting the true vapor pressure of crude oil from the Reid vapor pressure are known to have an upward bias. When the true vapor pressure of a crude oil is greater than 3.6 psia, it may be determined more accurately by means of direct measurement using ASTM D 6377. A curve of true vapor pressure versus temperature may be obtained by conducting ASTM D 6377 measurements over a range of temperatures.

$$P = \exp \left\{ \left[\left(\frac{2,799}{T + 459.6} \right) - 2.227 \right] \log_{10}(\text{RVP}) - \left(\frac{7,261}{T + 459.6} \right) + 12.82 \right\}$$

Where:

- P = stock true vapor pressure, in pounds per square inch absolute.
- T = stock temperature, in degrees Fahrenheit.
- RVP = Reid vapor pressure, in pounds per square inch.

Note: This equation was derived from a regression analysis of points read off Figure 7.1-13a over the full range of Reid vapor pressures, slopes of the ASTM distillation curve at 10 percent evaporated, and stock temperatures. In general, the equation yields *P* values that are within +0.05 pound per square inch absolute of the values obtained directly from the nomograph.

Figure 7.1-13b. Equation for true vapor pressure of crude oils with Reid vapor pressures of 2 to 15 psi.⁴
See note at Figure 7.1-13a.

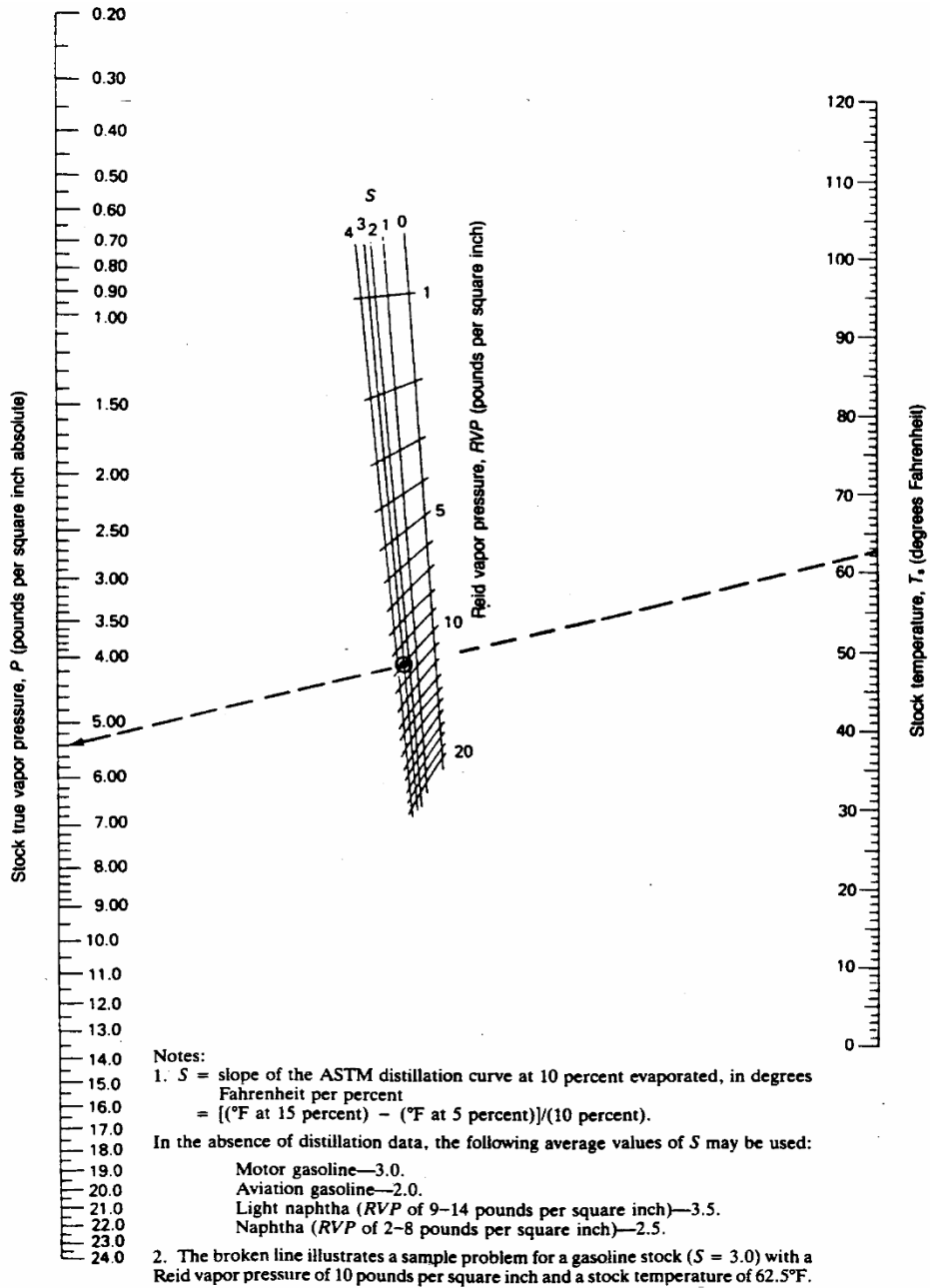

Figure 7.1-14a. True vapor pressure of refined petroleum stocks with Reid vapor pressures of 1 to 20 psi.⁴

Note 1. The “stock temperature, T ” in Figure 7.1-14a shall be taken as the liquid surface temperature, T_{LA} .

Note 2. True vapor pressure of refined petroleum stocks that are below the range of the Reid vapor pressure method may be measured directly using ASTM D 2879. A curve of true vapor pressure versus temperature may be obtained by conducting ASTM D 2879 measurements over a range of temperatures. Caution should be exercised when considering ASTM D 2879 for determining the true vapor pressure of certain types of mixtures. See the cautions in Note 2 to Equation 1-24 with respect to ASTM D 2879.

$$P = \exp \left\{ \left[0.7553 - \left(\frac{413.0}{T + 459.6} \right) \right] S^{0.5} \log_{10}(\text{RVP}) - \left[1.854 - \left(\frac{1,042}{T + 459.6} \right) \right] S^{0.5} + \left[\left(\frac{2,416}{T + 459.6} \right) - 2.013 \right] \log_{10}(\text{RVP}) - \left(\frac{8,742}{T + 459.6} \right) + 15.64 \right\}$$

Where:

P = stock true vapor pressure, in pounds per square inch absolute.
T = stock temperature, in degrees Fahrenheit.
RVP = Reid vapor pressure, in pounds per square inch.
S = slope of the ASTM distillation curve at 10 percent evaporated, in degrees Fahrenheit per percent.

Note: This equation was derived from a regression analysis of points read off Figure 7.1-14a over the full range of Reid vapor pressures, slopes of the ASTM distillation curve at 10 percent evaporated, and stock temperatures. In general, the equation yields *P* values that are within +0.05 pound per square inch absolute of the values obtained directly from the nomograph.

Figure 7.1-14b. Equation for true vapor pressure of refined petroleum stocks with Reid vapor pressures of 1 to 20 psi. ⁴ See note at Figure 7.1-14a.

$$A = 15.64 - 1.854 S^{0.5} - (0.8741 - 0.3280 S^{0.5}) \ln(\text{RVP})$$

$$B = 8,742 - 1,042 S^{0.5} - (1,049 - 179.4 S^{0.5}) \ln(\text{RVP})$$

where:

RVP = stock Reid vapor pressure, in pounds per square inch
ln = natural logarithm function
S = stock ASTM-D86 distillation slope at 10 volume percent evaporation (°F/vol%)

Figure 7.1-15. Equations to determine vapor pressure constants A and B for refined petroleum stocks. ²²

$$A = 12.82 - 0.9672 \ln(\text{RVP})$$

$$B = 7,261 - 1,216 \ln(\text{RVP})$$

where:

RVP = Reid vapor pressure, in pounds per square inch
ln = natural logarithm function

Figure 7.1-16. Equations to determine vapor pressure Constants A and B for crude oil stocks. ²²

Average Daily Maximum and Minimum Liquid Surface Temperature (°R)

$$T_{LX} = T_{LA} + 0.25 \Delta T_V$$

$$T_{LN} = T_{LA} - 0.25 \Delta T_V$$

where:

T_{LX} = average daily maximum liquid surface temperature, °R

T_{LA} = defined in Note 3 to Equation 1-24

ΔT_V = defined in Note 1 to Equation 1-5

T_{LN} = average daily minimum liquid surface temperature, °R

Figure 7.1-17. Equations for the average daily maximum and minimum liquid surface temperatures. ⁸

Figure 7.1-18. Reserved.

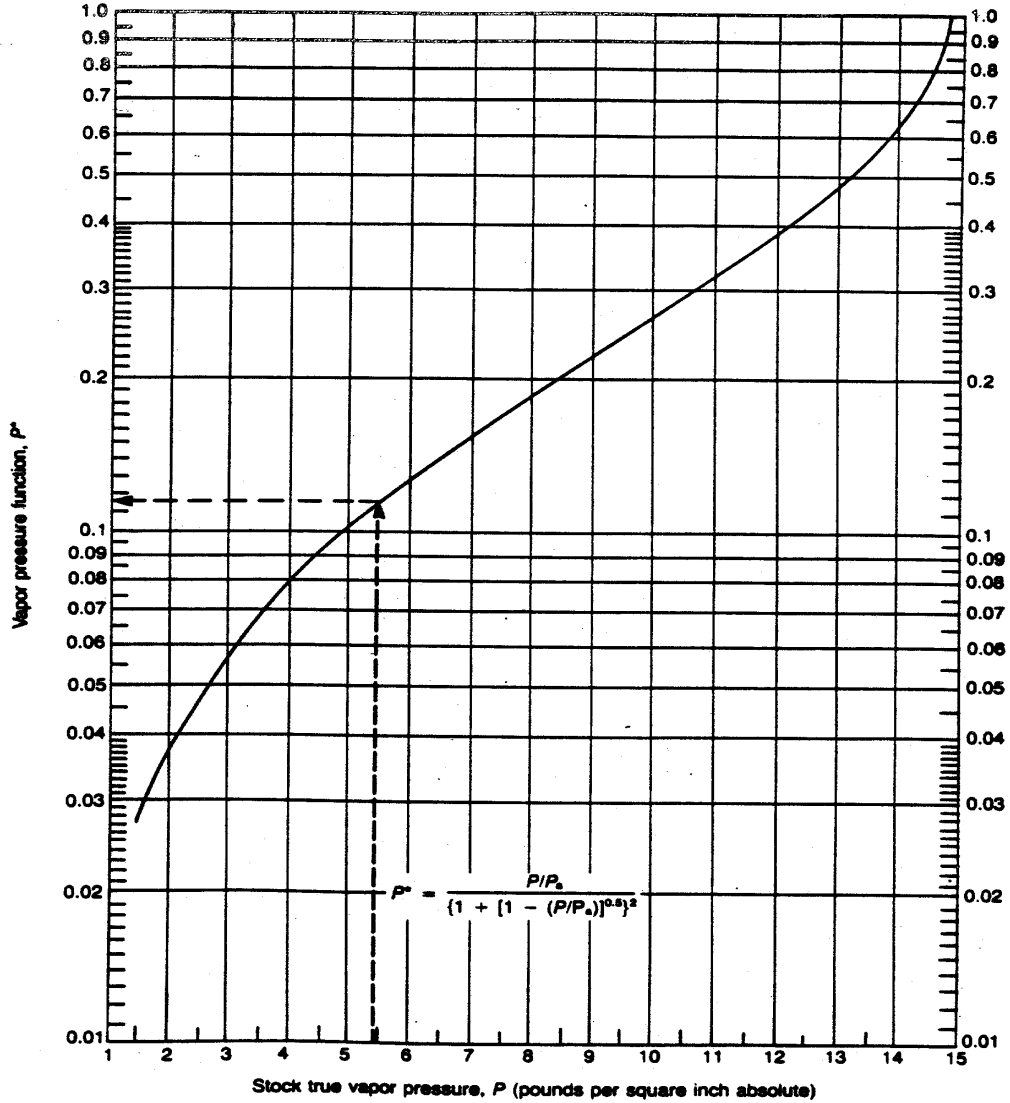

Notes:

1. Broken line illustrates sample problem for $P = 5.4$ pounds per square inch absolute.
2. Curve is for atmospheric pressure, P_a , equal to 14.7 pounds per square inch absolute.

Figure 7.1-19. Vapor pressure function.⁴

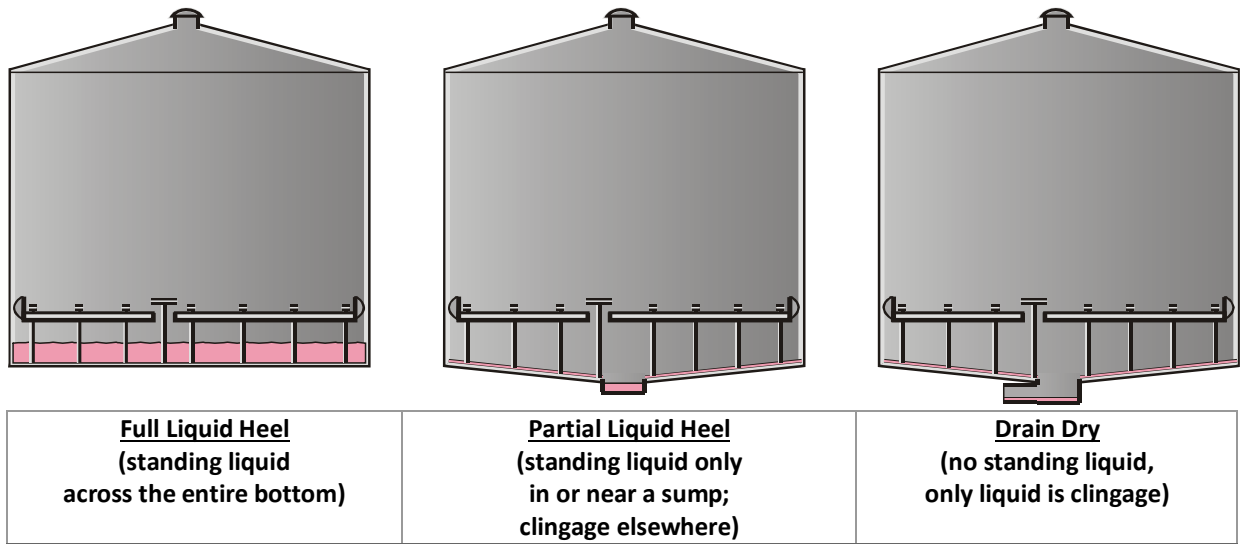

Figure 7.1-20. Bottom conditions for landing loss.²⁰

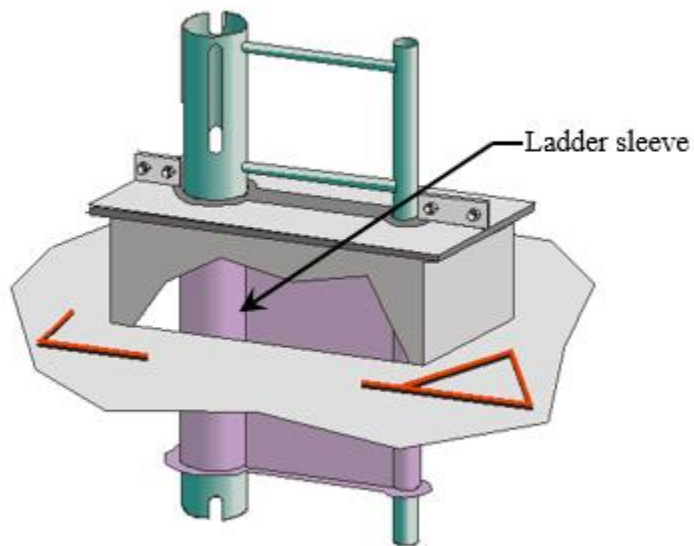

Figure 7.1-21. Ladder-slotted guidepole combination with ladder sleeve.²⁰

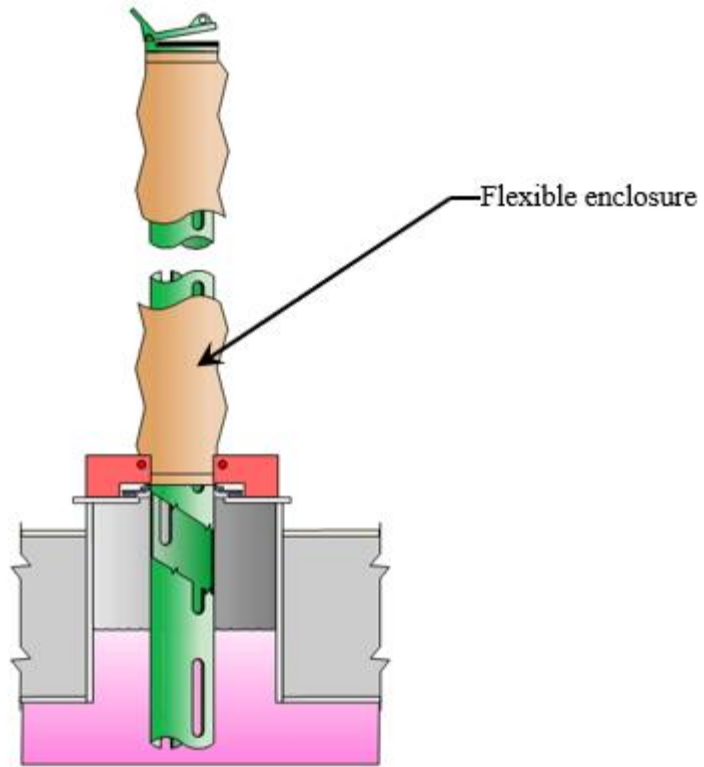

Figure 7.1-22. Slotted-guidepole with flexible enclosure.²⁰

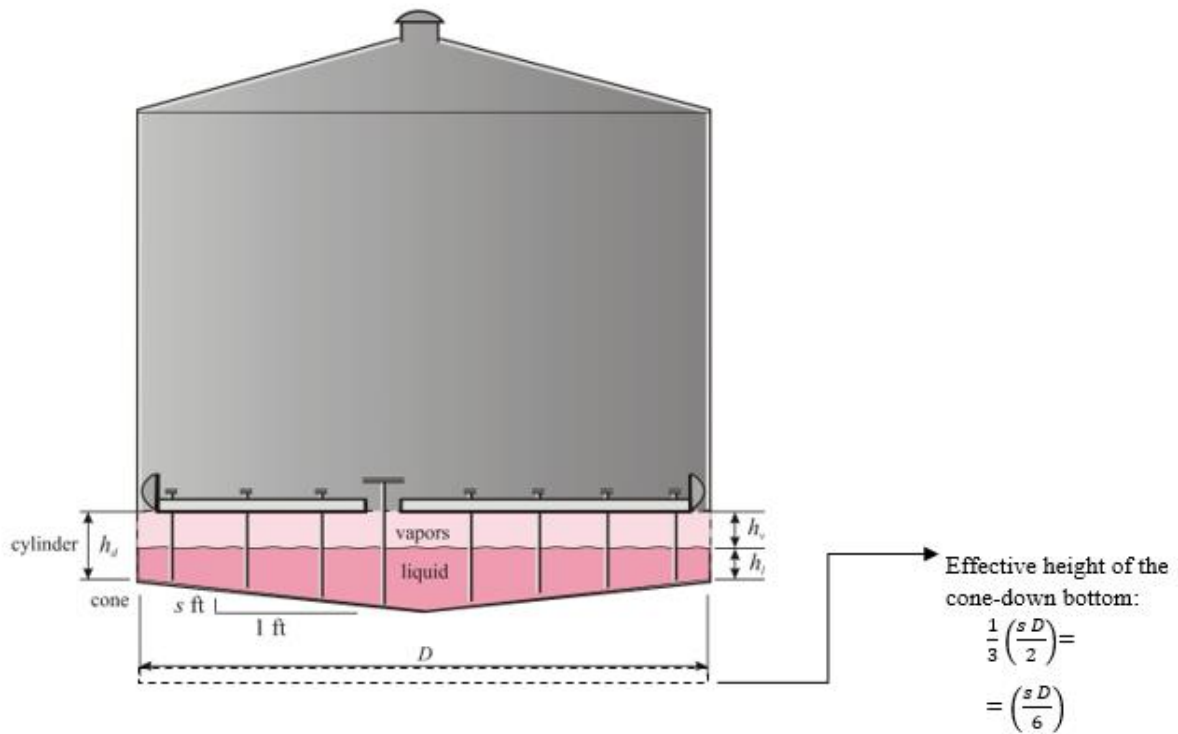

Figure 7.1-23. Height of the liquid heel and vapor space under a landed floating roof.²⁰ This figure illustrates variables used in Table 7.1-4.

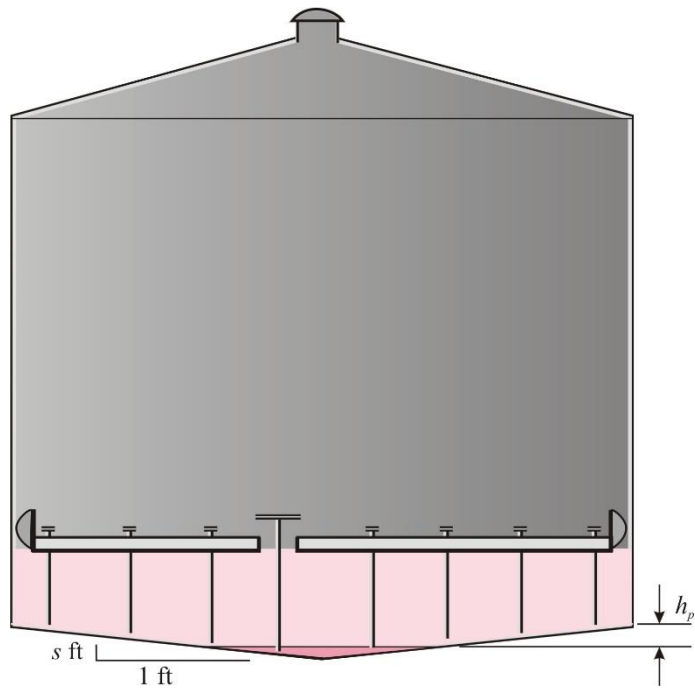

Figure 7.1-24. Depth of a partial heel in a cone down bottom.²⁰ This figure illustrates a variable used in Table 7.1-4.

Table 7.1-1. List Of Abbreviations Used In The Tank Equations

| Variable | Variable Description |
|-----------------|---|
| α | tank surface solar absorptance, dimensionless |
| π | constant, (3.14159) |
| A | constant in vapor pressure equation, dimensionless |
| A_{deck} | area of deck, ft ² |
| A_{fi} | liquid surface area within a particular type of deck fitting, in ² |
| B | constant in vapor pressure equation, °R or °C |
| C | constant in vapor pressure equation, °R or °C |
| C_s | shell clingage factor, bbl/1,000 ft ² |
| C_{sf} | filling saturation correction factor for wind, dimensionless |
| C_v | average vapor concentration by volume during continued forced ventilation, dimensionless |
| D | tank diameter, ft |
| D_E | effective tank diameter, ft |
| d_s | average depth of sludge, in. |
| F_C | effective column diameter, ft |
| F_E | fraction of sludge with potential to evaporate, dimensionless |
| F_F | total deck fitting loss factor, lb-mole/yr |
| h_d | deck leg height at the tank shell, ft |
| H_L | liquid height, ft |
| h_{le} | effective liquid height during roof landing, ft |
| H_{LN} | minimum liquid height, ft |
| H_{LX} | maximum liquid height, ft |
| ΣH_{QD} | the annual sum of the decreases in liquid level, ft/yr |
| ΣH_{QI} | the annual sum of the increases in liquid level, ft/yr |
| H_R | tank roof height, ft |
| H_{RO} | roof outage, ft |
| H_s | tank shell height, ft |
| h_v | vapor space height under landed floating roof, ft |
| H_{VO} | vapor space outage, ft |
| i | 1,2,.....n, dimensionless |
| I | average daily total insolation factor, Btu/ft ² •d |
| K_C | product factor for floating roof tanks, dimensionless |
| K_D | deck seam loss per unit seam length factor, lb-mole/ft•yr |
| K_E | vapor space expansion factor, per day |
| K_{Fai} | zero wind speed loss factor for a particular type of deck fitting, lb-mole/yr |
| K_{Fbi} | wind speed dependent loss factor for a particular type of deck fitting, lb-mole/(mph) ^m yr |
| K_{Fi} | loss factor for a particular type of deck fitting, lb-mole/yr |
| K_N | turnover factor, dimensionless |
| K_P | working loss product factor for fixed roof tanks, dimensionless |
| K_{Ra} | zero wind speed rim seal loss factor, lb-mole/ft•yr |
| K_{Rb} | wind speed dependent rim seal loss factor, lb-mole/ (mph) ⁿ ft•yr |
| K_S | vented vapor saturation factor, dimensionless |
| K_v | fitting wind speed correction factor, dimensionless |
| L | length of tank, ft |
| L_C | clingage factor for drain dry tanks, lb |
| L_{CV} | continued forced ventilation emissions, lb/cleaning event |
| L_D | deck seam loss, lb/yr |

| Variable | Variable Description |
|--------------|--|
| L_F | deck fitting loss, lb/yr |
| L_{FV} | total tank cleaning emissions due to forced ventilation, lb/cleaning event |
| L_{FL} | filling loss during roof landing, lb/landing event |
| L_P | vapor space purge emissions due to first air change from forced ventilation, lb/cleaning event |
| L_R | rim seal loss, lb/yr |
| L_{RL} | rim seal loss during roof landing, lb/landing event |
| L_S | standing losses, lb/yr |
| L_{seam} | total length of deck seam, ft |
| L_{SL} | standing loss during roof landing, lb/landing event |
| L_T | total routine losses, lb/yr |
| L_{T_i} | emission rate of component i, lb/yr |
| L_{TL} | total loss during roof landing, lb/landing event |
| L_V | variable vapor space filling loss, lb/1,000 gal throughput |
| L_W | working losses, lb/yr |
| M_{CG} | molecular weight of calibration gas, lb/lb-mole |
| m_i | loss factor for a particular type of deck fitting, dimensionless |
| M_i | molecular weight of component i, lb/lb-mole |
| M_L | molecular weight of liquid mixture, lb/lb-mole |
| M_V | vapor molecular weight, lb/lb-mole |
| N | number of turnovers per year, dimensionless |
| n | seal-related wind speed exponent, dimensionless |
| n_d | number of days standing idle during roof landing or prior to forced ventilation, days |
| N_2 | number of transfers into system, dimensionless |
| N_C | number of columns, dimensionless |
| n_{CV} | duration of continued forced ventilation, days |
| N_d | number of drains |
| n_f | total number of different types of fittings, dimensionless |
| N_{Fa_i} | zero wind speed loss factor for a particular type of deck fitting, lb-mole/yr |
| N_{Fb_i} | wind speed dependent loss factor for a particular type of fitting, lb-mole/ mph ^m •yr |
| N_{F_i} | number of deck fittings of a particular type, dimensionless |
| N_l | number of deck legs |
| N_{TOTAL} | total number of moles in mixture, lb-mole |
| N_{vb} | number of vacuum breakers |
| P | true vapor pressure of component i, psia |
| P^* | vapor pressure function, dimensionless |
| P_A | atmospheric pressure, psi |
| ΔP_B | breather vent pressure setting range, psig |
| P_{BP} | breather vent pressure setting, psig |
| P_{BV} | breather vent vacuum setting, psig |
| P_i | gauge pressure within the vapor space, psig |
| P_i | partial pressure of component i, psia |
| ΔP_V | average daily vapor pressure range, psi |
| P_V | vapor pressure at average ambient temperature, psia |
| P_{VA} | vapor pressure at average daily liquid surface temperature, psia |
| P_{VN} | vapor pressure at the average daily minimum liquid surface temperature, psia |
| P_{VX} | vapor pressure at the average daily maximum liquid surface temperature, psia |
| Q | annual net throughput, bbl/yr |
| Q_V | average ventilation rate during tank cleaning, ft ³ /min |

| Variable | Variable Description |
|----------------------------|---|
| R | ideal gas constant, (10.731 psia•ft ³ /lb-mole•°R) |
| R _R | tank dome roof radius, ft |
| R _S | tank shell radius, ft |
| S | filling saturation factor, dimensionless |
| s | tank cone bottom slope, ft/ft |
| S _D | deck seam length factor, ft/ft ² |
| S _R | tank cone roof slope, ft/ft |
| ΔT _A | average daily ambient temperature range, °R |
| T _{AA} | average daily ambient temperature, °R |
| T _{AN} | average daily minimum ambient temperature, °R |
| T _{AX} | average daily maximum ambient temperature, °R |
| T _B | liquid bulk temperature, °R |
| T _{BN} | typical minimum liquid bulk temperature in heating cycles, °R |
| T _{BX} | typical maximum liquid bulk temperature in heating cycles, °R |
| T _{LA} | average daily liquid surface temperature, °R |
| T _V | average vapor temperature, °R |
| t _v | daily period of forced ventilation during tank cleaning, hr/day |
| ΔT _V | average daily vapor temperature range, °R |
| v | average wind speed, mph |
| V ₁ | volume of liquid pumped into system, bbl/yr |
| V ₂ | volume expansion capacity, bbl |
| V _Q | net working loss throughput, ft ³ /yr |
| V _{LX} | tank maximum liquid volume, ft ³ |
| V _V | vapor space volume, ft ³ |
| W _i | liquid density of component i, lb/ft ³ |
| W _L | average organic liquid density, lb/gal |
| W _V | vapor density, lb/ft ³ |
| x _i | liquid mole fraction of component i, lb-mole/lb-mole |
| y _i | vapor mole fraction of component i, lb-mole/lb-mole |
| Z _{L_i} | liquid weight fraction of component i, lb/lb |
| Z _{V_i} | vapor weight fraction of component i, lb/lb |

Table 7.1-2. Properties (M_v , M_L , P_{VA} , W_L) Of Selected Petroleum Liquids^{a, e, h}

| Petroleum Liquid Mixture | Vapor Molecular Weight ^a (M_v) lb/lb-mole | Liquid Molecular Weight ^b (M_L) lb/lb-mole | Liquid Density ^a (W_L) lb/gal | ASTM D86 Distillation Slope ^c (S) °F/vol % | Vapor Pressure Equation Constant ^d (A) dimensionless | Vapor Pressure Equation Constant ^d (B) °R | True Vapor Pressure (at 60 °F) (P_{VA}) psia |
|----------------------------------|--|---|--|---|---|--|--|
| Midcontinent Crude Oil | 50 | 207 | 7.1 | – | Figure 7.1-16 | Figure 7.1-16 | – |
| Refined Petroleum Stocks | – | – | – | – | Figure 7.1-15 | Figure 7.1-15 | – |
| Motor Gasoline RVP 13 | 62 | 92 | 5.6 | 3.0 | 11.644 | 5043.6 | 7.0 |
| Motor Gasoline RVP 10 | 66 ^e | 92 | 5.6 | 3.0 | 11.724 | 5237.3 | 5.2 |
| Motor Gasoline RVP 7 | 68 | 92 | 5.6 | 3.0 | 11.833 | 5500.6 | 3.5 |
| Light Naphtha RVP 9-14 | – | – | – | 3.5 | – | – | – |
| Naphtha RVP 2-8 | – | – | – | 2.5 | – | – | – |
| Aviation Gasoline | – | – | – | 2.0 | – | – | – |
| Jet Kerosene (Jet A) | 130 | 162 | 7.0 | – | 12.390 | 8933.0 | 0.008 |
| No. 2 Fuel Oil (Diesel) | 130 | 188 | 7.1 | – | 12.101 | 8907.0 | 0.006 |
| No. 6 Fuel Oil ^f | 130 | 387 | 7.9 | – | 10.781 | 8933.0 | 0.002 |
| Vacuum Residual Oil ^g | 190 | 387 | 7.9 | – | 10.104 | 10,475.5 | 0.00004 |

^a References 10 and 11

^b Liquid molecular weights from “Memorandum from Patrick B. Murphy, Radian/RTP to James F. Durham, EPA/CPB Concerning Petroleum Refinery Liquid HAP and Properties Data, August 10, 1993,” as adopted in versions 3.1 and 4.0 of EPA’s TANKS software.

^c Reference 4.

^d For motor gasolines, see Figure 7.1-15;
 for crude oil, see Figure 7.1-16;
 for Jet Naphtha, Jet Kerosene, and No. 2 Fuel Oil, see Barnett and Hibbard¹⁰;
 for No. 6 Fuel Oil.²²

^e Alternatively, in the absence of measured data, a value of 66 lb/lb-mole may be assumed for all gasolines, in that the variability shown as a function of RVP is speculative.

^f This is for a blend of Vacuum Residual Oil with a light distillate cutter stock, or similar mixture. Vapor pressure constants given will result in higher vapor pressure values than shown previously in AP-42 for Residual Oil No. 6.

^g This is the straight residue from the bottom of the vacuum distillation column, prior to any further processing or blending. Properties given for Vacuum Residual Oil are those given for Residual Oil No. 6 previously in AP-42.

^h Jet Naphtha (JP-4) was removed from this table because it is no longer produced or procured. “Coordinating Research Council, Aviation Fuel Properties Handbook, CRC Report No. 663”

Table 7.1-3. Physical Properties Of Selected Organic Chemicals^a

| Chemical Name | CAS Registry No. | Molecular Weight | Liquid Density ^d (lb/gal) | True Vapor Pressure at 60 °F (psia) | Constant ^b A dimensionless | Constant ^b B (°C) | Constant ^b C (°C) | Temperature Range ^{b,c} Minimum (°F) | Temperature Range ^{b,c} Maximum (°F) | Normal Boiling Point (°F) |
|--|------------------|------------------|--------------------------------------|-------------------------------------|---------------------------------------|------------------------------|------------------------------|---|---|---------------------------|
| Acetaldehyde | 00075-07-0 | 44.05 | 6.54 ⁶⁴ | 12.19 | 8.063 | 1,637.1 | 295.47 | 32 | 94 | 69 |
| Acetic acid | 00064-19-7 | 60.05 | 8.72 ⁷⁷ | 0.176 | 7.557 | 1,642.5 | 233.39 | 63 | 244 | 244 |
| Acetic anhydride {acetic acid anhydride} | 00108-24-7 | 102.09 | 9.03 | 0.053 | 7.122 | 1,427.8 | 198.04 | 145 | 283 | 282 |
| Acetone | 00067-64-1 | 58.08 | 6.55 ⁷⁷ | 2.921 | 7.300 | 1,312.3 | 240.71 | 7 | 454 | 133 |
| Acetonitrile | 00075-05-8 | 41.05 | 6.56 | 1.090 | 7.154 | 1,355.4 | 235.30 | 59 | 192 | 179 |
| Acrylamide | 00079-06-1 | 71.08 | 9.36 | 8.57E-05 | 11.293 | 3,939.9 | 273.16 | | | 379 |
| Acrylic acid {2-propenoic acid} | 00079-10-7 | 72.06 | 8.77 | 1.344 | 5.652 | 648.6 | 154.68 | 68 | 158 | 282 |
| Acrylonitrile {2-propenenitrile} | 00107-13-1 | 53.06 | 6.73 | 1.383 | 6.942 | 1,255.9 | 231.30 | -60 | 172 | 172 |
| Allyl alcohol | 00107-18-6 | 58.08 | 7.13 | 0.326 | 11.658 | 4,510.2 | 416.80 | 70 | 207 | 206 |
| Allyl chloride {3-chloro-1-propene} | 00107-05-1 | 76.52 | 7.83 | 4.702 | 5.297 | 418.4 | 128.68 | 55 | 111 | 113 |
| Aniline | 00062-53-3 | 93.13 | 8.53 | 0.0058 | 7.221 | 1,661.9 | 199.10 | 88 | 363 | 363 |
| Benzene | 00071-43-2 | 78.11 | 7.32 | 1.171 | 6.906 | 1,211.0 | 220.79 | 46 | 217 | 176 |
| Benz[a]anthracene | 00056-55-3 | 228.29 | | 7.92E-10 | 11.528 | 5,461 | 273.15 | 219 | 260 | 820 |
| Benzo[a]pyrene | 00050-32-8 | 252.31 | | 2.29E-11 | 12.482 | 6,181 | 273.15 | 185 | 316 | 923 |
| Benzo[ghi]perylene | 00191-24-2 | 276.33 | | 2.07E-13 | 11.820 | 6,580 | 273.15 | 391 | 513 | |
| Biphenyl | 00092-52-4 | 154.21 | 8.68 | 2.37E-04 | 7.245 | 1,998.7 | 202.73 | 156 | 520 | 489 |
| Butadiene (1,3) {divinyl} | 00106-99-0 | 54.09 | 5.13 ⁷⁷ | 30.22 | 6.873 | 941.7 | 240.40 | -104 | 29 | 24 |
| Butane (n) | 00106-97-8 | 58.12 | 4.78 ⁷⁷ | 25.67 | 6.725 | 909.7 | 237.00 | -108 | 31 | 32 |
| Butene (1) | 00106-98-9 | 56.11 | 4.91 ⁷⁷ | 30.83 | 7.122 | 1,099.2 | 264.89 | -108 | 25 | 21 |
| Butene (cis-2) | 00590-18-1 | 56.11 | 5.14 ⁷⁷ | 22.62 | 6.863 | 957.1 | 236.65 | -94 | 73 | 39 |
| Butene (2-methyl-1) | 00563-46-2 | 70.13 | 5.43 | 8.257 | 6.862 | 1,047.8 | 232.06 | 34 | 145 | 88 |
| Butene (trans-2) | 00624-64-6 | 56.11 | 5.00 ⁷⁷ | 24.97 | 6.919 | 982.2 | 242.38 | -97 | 34 | 34 |

| Chemical Name | CAS Registry No. | Molecular Weight | Liquid Density ^d (lb/gal) | True Vapor Pressure at 60 °F (psia) | Constant ^b A dimensionless | Constant ^b B (°C) | Constant ^b C (°C) | Temperature Range ^{b,c} Minimum (°F) | Temperature Range ^{b,c} Maximum (°F) | Normal Boiling Point (°F) |
|--|------------------|------------------|--------------------------------------|-------------------------------------|---------------------------------------|------------------------------|------------------------------|---|---|---------------------------|
| Butyl alcohol (n) {butanol (1)} | 00071-36-3 | 74.12 | 6.76 | 0.062 | 7.421 | 1,351.6 | 179.81 | 73 | 244 | 243 |
| Butyl alcohol (tert) {1,1-dimethyl ethanol} | 00075-65-0 | 74.12 | 6.58 | 0.424 | 7.373 | 1,174.9 | 179.23 | 103 | 180 | 180 |
| Butyl chloride (n) {1-chloro-butane} | 00109-69-3 | 92.57 | 7.40 | 1.255 | 6.871 | 1,182.9 | 218.27 | 2 | 173 | 170 |
| Butyl ether (di-tert) | 06163-66-2 | 130.23 | 6.39 | 0.381 | 6.590 | 1,157.7 | 203.05 | 39 | 228 | 224 |
| Carbon disulfide | 00075-15-0 | 76.14 | 10.54 | 4.817 | 6.942 | 1,168.6 | 241.53 | 38 | 176 | 115 |
| Carbon tetrachloride | 00056-23-5 | 153.82 | 13.31 | 1.431 | 6.898 | 1,221.8 | 227.41 | 68 | 172 | 170 |
| Chlorobenzene | 00108-90-7 | 112.56 | 9.23 | 0.134 | 6.986 | 1,435.7 | 218.03 | 144 | 269 | 269 |
| Chlorobutane (2) | 00078-86-4 | 92.57 | 7.27 | 1.255 | 6.871 | 1,182.9 | 218.27 | 2 | 173 | 170 |
| Chloroform | 00067-66-3 | 119.38 | 12.38 | 2.468 | 7.083 | 1,233.1 | 232.20 | -73 | 142 | 142 |
| Chloroprene {2-chloro-1,3-butadiene} | 00126-99-8 | 88.54 | 7.98 | 2.736 | 6.291 | 841.9 | 187.79 | 68 | 140 | 140 |
| Chlorotoluene (o) {1-chloro-2methylbenzene } | 00095-49-8 | 126.58 | 9.04 | 0.039 | 7.363 | 1,768.1 | 234.76 | 42 | 319 | 318 |
| Chrysene {benzo[a]phenanthrene} | 00218-01-9 | 228.29 | 10.63 | 1.86E-11 | 12.320 | 6,160 | 273.15 | 185 | 374 | 838 |
| Cresol (m) {3-methyl-phenol} | 00108-39-4 | 108.14 | 8.63 | 0.0013 | 7.477 | 1,833.1 | 196.74 | 301 | 394 | 396 |
| Cresol (o) {2-methyl-phenol} | 00095-48-7 | 108.14 | 9.47 ⁷⁷ | 0.0016 | 6.843 | 1,391.3 | 160.18 | 248 | 376 | 376 |

| Chemical Name | CAS Registry No. | Molecular Weight | Liquid Density ^d (lb/gal) | True Vapor Pressure at 60 °F (psia) | Constant ^b A dimensionless | Constant ^b B (°C) | Constant ^b C (°C) | Temperature Range ^{b,c} Minimum (°F) | Temperature Range ^{b,c} Maximum (°F) | Normal Boiling Point (°F) |
|---|------------------|------------------|--------------------------------------|-------------------------------------|---------------------------------------|------------------------------|------------------------------|---|---|---------------------------|
| Cresol (p) {4-methyl-phenol} | 00106-44-5 | 108.14 | 8.50 ¹⁰⁴ | 0.00062 | 7.016 | 1,498.6 | 160.55 | 262 | 395 | 395 |
| Cyclohexane | 00110-82-7 | 84.16 | 6.46 ⁷⁷ | 1.212 | 6.845 | 1,203.5 | 222.86 | 68 | 179 | 177 |
| Cyclohexanol | 00108-93-0 | 100.16 | 8.03 | 0.00090 | 5.956 | 777.4 | 91.11 | 201 | 321 | 320 |
| Cyclohexanone | 00108-94-1 | 98.14 | 7.91 | 0.0042 | 5.978 | 1,495.5 | 209.55 | 193 | 330 | 311 |
| Cyclohexene | 00110-83-8 | 82.14 | 6.77 | 0.110 | 5.872 | 1,221.9 | 223.17 | 98 | 196 | 181 |
| Cyclopentane | 00287-92-3 | 70.13 | 6.22 | 4.171 | 6.878 | 1,119.2 | 230.74 | 60 | 122 | 121 |
| Cyclopentanone | 00120-92-3 | 84.12 | 7.92 | 0.130 | 3.958 | 376.4 | 104.65 | 32 | 78 | 266 |
| Cyclopentene | 00142-29-0 | 68.12 | 6.44 | 3.264 | 6.921 | 1,121.8 | 223.45 | | | 111 |
| Decane (-n) | 00124-18-5 | 142.28 | 6.09 | 0.011 | 3.085 | 440.6 | 116.25 | -21 | 99 | 345 |
| Dibromoethane (1,2) | 00106-93-4 | 187.86 | 18.08 | 0.13 | 6.508 | 1,156.4 | 187.45 | 40 | 130 | 267.8 |
| Dibromopropane (1,2) | 00078-75-1 | 201.89 | 16.13 | 0.088 | 7.314 | 1,667.0 | 234.85 | 19 | 287 | 286 |
| Dibromopropane (1,3) | 00109-64-8 | 201.89 | 16.55 | 0.029 | 7.309 | 1,776.7 | 233.46 | 49 | 333 | 314 |
| Dichloroethane (1,1) | 00075-34-3 | 98.96 | 9.81 | 2.863 | 7.097 | 1,229.2 | 233.95 | -77 | 135 | 135 |
| Dichloroethane (1,2) | 00107-06-2 | 98.96 | 10.40 ⁷⁷ | 0.961 | 7.460 | 1,521.8 | 248.48 | -23 | 211 | 182 |
| Dichloroethylene (1,2) {1,2 dichloroethene} | 00540-59-0 | 96.94 | 10.76 | 2.579 | 7.022 | 1,205.4 | 230.60 | 32 | 183 | 141 |
| Dichloroethylene (trans-1,2) | 00156-60-5 | 96.94 | 10.49 | 4.333 | 6.965 | 1,141.9 | 231.90 | -36 | 185 | 118 |
| Dichlorotoluene (3,4) | 00095-75-0 | 161.03 | 10.49 | 0.0029 | 7.344 | 1,882.5 | 215.00 | 32 | 221 | 408 |
| Diethoxyethane (1,1) | 00105-57-7 | 118.17 | 6.89 | 0.307 | 7.625 | 1,574.0 | 229.47 | -10 | 216 | 212 |

| Chemical Name | CAS Registry No. | Molecular Weight | Liquid Density ^d (lb/gal) | True Vapor Pressure at 60 °F (psia) | Constant ^b A dimensionless | Constant ^b B (°C) | Constant ^b C (°C) | Temperature Range ^{b,c} Minimum (°F) | Temperature Range ^{b,c} Maximum (°F) | Normal Boiling Point (°F) |
|--|------------------|------------------|--------------------------------------|-------------------------------------|---------------------------------------|------------------------------|------------------------------|---|---|---------------------------|
| Diethoxymethane | 00462-95-3 | 104.15 | 6.94 | 0.810 | 6.986 | 1,270.2 | 221.26 | 32 | 167 | 191 |
| Diethyl (n,n) aniline {N,N-diethylbenzamine} | 00091-66-7 | 149.23 | 7.77 | 0.0031 | 8.258 | 2,652.8 | 277.32 | 122 | 425 | 422 |
| Diethyl ketone {3-pentanone} | 00096-22-0 | 86.13 | 6.76 ⁷⁷ | 0.423 | 5.741 | 716.2 | 147.17 | 97 | 215 | 215 |
| Diethyl sulfide | 00352-93-2 | 90.19 | 6.98 | 0.749 | 7.541 | 1,560.5 | 246.59 | -39 | 190 | 197 |
| Diethylamine {N-ethyl ethanamine} | 00109-89-7 | 73.14 | 5.89 | 2.712 | 5.737 | 559.1 | 140.18 | 89 | 141 | 132 |
| Diethylbenzene (1,2) | 00135-01-3 | 134.22 | 7.34 | 0.0094 | 6.990 | 1,577.9 | 200.55 | 206 | 364 | 361 |
| Diethylbenzene (1,3) | 00141-93-5 | 134.22 | 7.18 | 0.010 | 7.006 | 1,576.3 | 201.00 | 203 | 360 | 358 |
| Diethylbenzene (1,4) | 00105-05-5 | 134.22 | 7.20 | 0.010 | 7.001 | 1,589.3 | 202.02 | 206 | 365 | 363 |
| Di-isopropyl ether | 00108-20-3 | 102.17 | 6.04 | 1.877 | 6.842 | 1,135.0 | 218.23 | 74 | 153 | 155 |
| Dimethoxyethane (1,2) | 00110-71-4 | 90.12 | 7.25 | 0.966 | 6.713 | 1,260.5 | 235.83 | -55 | 199 | 185 |
| Dimethyl formamide (n,n) | 00068-12-2 | 73.09 | 7.88 ⁷⁷ | 0.040 | 6.806 | 1,337.7 | 190.50 | 86 | 194 | 307 |
| Dimethyl hydrazine (1,1) | 00057-14-7 | 60.10 | 6.60 ⁷² | 1.896 | 7.588 | 1,388.5 | 232.54 | -32 | 68 | 146 |
| Dimethyl phthalate | 00131-11-3 | 194.18 | 9.94 | 2.25E-08 | 4.522 | 700.3 | 51.42 | 180 | 304 | 540 |
| Dimethylbutane (2,3) | 00079-29-8 | 86.18 | 5.52 | 3.064 | 6.810 | 1,127.2 | 228.95 | 58 | 138 | 136 |
| Dimethylcyclopentane (1,1) | 01638-26-2 | 98.19 | 6.26 ⁷⁷ | 0.932 | 6.830 | 1,226.6 | 222.76 | 60 | 192 | 190 |
| Dimethylpentane (2,2) | 00590-35-2 | 100.20 | 5.63 | 1.315 | 6.815 | 1,190.3 | 223.34 | 60 | 176 | 174 |
| Dimethylpentane (2,3) | 00565-59-3 | 100.20 | 5.80 | 0.842 | 6.862 | 1,242.6 | 222.34 | 64 | 195 | 194 |

| Chemical Name | CAS Registry No. | Molecular Weight | Liquid Density ^d (lb/gal) | True Vapor Pressure at 60 °F (psia) | Constant ^b A dimensionless | Constant ^b B (°C) | Constant ^b C (°C) | Temperature Range ^{b,c} Minimum (°F) | Temperature Range ^{b,c} Maximum (°F) | Normal Boiling Point (°F) |
|---|------------------|------------------|--------------------------------------|-------------------------------------|---------------------------------------|------------------------------|------------------------------|---|---|---------------------------|
| Dimethylpentane (2,4) | 00108-08-7 | 100.20 | 5.62 | 1.221 | 6.836 | 1,197.6 | 222.27 | 57 | 178 | 177 |
| Dimethylpentane (3,3) | 00562-49-2 | 100.20 | 5.79 | 1.029 | 6.831 | 1,231.0 | 225.58 | 56 | 189 | 187 |
| Dioxane (1,4) | 00123-91-1 | 88.11 | 8.63 | 0.439 | 7.456 | 1,570.1 | 241.85 | 68 | 221 | 214 |
| Dipropyl ether {di- <i>n</i> -propyl ether} | 00111-43-3 | 102.17 | 6.23 | 0.754 | 6.945 | 1,254.8 | 218.82 | 80 | 192 | 194 |
| Dodecane (<i>n</i>) | 00112-40-3 | 170.33 | 6.25 | 0.00093 | 6.981 | 1,625.9 | 180.31 | 259 | 423 | 421 |
| Epichlorohydrin {chloromethyl oxirane} | 00106-89-8 | 92.52 | 9.85 | 0.194 | 8.229 | 2,086.8 | 273.16 | | | 241 |
| Ethane | 00074-84-0 | 30.07 | | 472 | 6.813 | 659.7 | 256.431 | -215 | -100 | -127 |
| Ethanolamine (mono) | 00141-43-5 | 61.08 | 8.50 | 0.002 | 7.168 | 1,408.9 | 157.06 | 150 | 340 | 339 |
| Ethyl acetate | 00141-78-6 | 88.11 | 7.51 | 1.135 | 7.103 | 1,245.7 | 217.96 | 60 | 168 | 171 |
| Ethyl acrylate {ethyl ester 2-propenoic acid} | 00140-88-5 | 100.12 | 7.71 | 0.445 | 7.150 | 1,366.1 | 220.47 | -21 | 211 | 211 |
| Ethyl alcohol {ethanol} | 00064-17-5 | 46.07 | 6.59 | 0.648 | 8.247 | 1,670.4 | 232.96 | 32 | 173 | 173 |
| Ethyl chloride | 00075-00-3 | 64.51 | 7.43 ⁷⁷ | 16.63 | 7.037 | 1,052.8 | 241.07 | -69 | 55 | 61 |
| Ethyl ether {diethyl ether} | 00060-29-7 | 74.12 | 5.96 | 6.675 | 6.897 | 1,062.6 | 228.22 | -10 | 132 | 94 |
| Ethylamine | 00075-04-7 | 45.08 | 5.65 ⁷⁷ | 14.08 | 7.405 | 1,203.8 | 249.43 | 62 | 349 | 64 |
| Ethylbenzene | 00100-41-4 | 106.17 | 7.24 | 0.104 | 6.950 | 1,419.3 | 212.61 | 134 | 279 | 277 |
| Ethylcyclopentane | 01640-89-7 | 98.19 | 6.40 | 0.475 | 6.898 | 1,305.0 | 221.40 | 84 | 220 | 218 |
| Ethylene {ethene} | 00074-85-1 | 28.05 | 4.74 ¹⁵⁵ | 749 | 6.748 | 584.1 | 254.84 | -191 | -120 | -155 |
| Ethyleneoxide | 00075-21-8 | 44.05 | 7.3650 | 17.84 | 8.722 | 2,022.8 | 335.81 | 32 | 89 | 53 |
| Ethylpentane (3) | 00617-78-7 | 100.20 | 5.83 | 0.701 | 6.880 | 1,254.1 | 220.15 | 70 | 202 | 200 |
| Fluoranthene | 00206-44-0 | 202.25 | 10.45 | 3.96E-08 | 12.836 | 5,348.1 | 273.15 | 77 | 230 | 723 |
| Fluorobenzene | 00462-06-6 | 96.10 | 8.53 | 0.936 | 7.237 | 1,409.8 | 238.36 | 0 | 183 | 185 |
| Formic acid | 00064-18-6 | 46.03 | 10.18 | 0.516 | 4.876 | 515.0 | 133.74 | 33 | 93 | 213 |

| Chemical Name | CAS Registry No. | Molecular Weight | Liquid Density ^d (lb/gal) | True Vapor Pressure at 60 °F (psia) | Constant ^b A dimensionless | Constant ^b B (°C) | Constant ^b C (°C) | Temperature Range ^{b,c} Minimum (°F) | Temperature Range ^{b,c} Maximum (°F) | Normal Boiling Point (°F) |
|--|------------------|------------------|--------------------------------------|-------------------------------------|---------------------------------------|------------------------------|------------------------------|---|---|---------------------------|
| Freon 11 {trichlorofluoro methane} | 00075-69-4 | 137.37 | 12.48 | 10.93 | 6.884 | 1,043.0 | 236.88 | | | 75 |
| Furan | 00110-00-9 | 68.07 | 7.94 | 7.963 | 6.975 | 1,060.8 | 227.73 | 37 | 143 | 89 |
| Furfural {2-furancarboxaldehyde} | 00098-01-1 | 96.09 | 9.68 | 0.018 | 6.969 | 1,430.1 | 188.70 | 133 | 321 | 323 |
| Heneicosane (n) | 00629-94-7 | 296.57 | 6.61 | 6.23E-07 | 8.796 | 3,571.2 | 253.20 | 307 | 663 | 679 |
| Heptane (n) | 00142-82-5 | 100.20 | 5.71 | 0.541 | 6.903 | 1,268.6 | 216.95 | 79 | 211 | 209 |
| Heptene (1) | 00592-76-7 | 98.19 | 5.82 | 0.752 | 7.093 | 1,400.7 | 238.96 | 32 | 192 | 201 |
| Hexadiene (1,5) | 00592-42-7 | 82.14 | 5.74 ⁷⁷ | 2.890 | 6.563 | 1,008.1 | 214.16 | 32 | 138 | 140 |
| Hexane (n) | 00110-54-3 | 86.18 | 5.47 ⁷⁷ | 1.913 | 6.878 | 1,171.5 | 224.37 | 55 | 157 | 156 |
| Hexanol (1) | 00111-27-3 | 102.17 | 6.79 | 0.005 | 7.288 | 1,422.0 | 165.44 | 126 | 315 | 314 |
| Hexene (1) | 00592-41-6 | 84.16 | 5.62 | 2.378 | 6.866 | 1,153.0 | 225.85 | 61 | 148 | 147 |
| Hydrogen cyanide {hydrocyanic acid} | 00074-90-8 | 27.03 | 5.74 | 9.931 | 7.549 | 1,340.8 | 261.56 | 2 | 115 | 79 |
| Isobutane {methylpropane (2)} | 00075-28-5 | 58.12 | 4.60 ⁷⁷ | 38.22 | 6.819 | 912.1 | 243.34 | -121 | 11 | 12 |
| Isobutene {methylpropene (2)} | 00115-11-7 | 56.11 | 4.92 ⁷⁷ | 32.18 | 6.522 | 799.1 | 226.54 | -70 | 32 | 20 |
| Isobutyl alcohol {2-methyl 1-propanol} | 00078-83-1 | 74.12 | 6.69 | 0.096 | 7.306 | 1,237.0 | 171.62 | 176 | 240 | 226 |
| Isooctane {2,2,4-trimethylpentane} | 00540-84-1 | 114.23 | 5.74 ⁷⁷ | 0.596 | 6.812 | 1,257.8 | 220.74 | 76 | 212 | 211 |
| Isopentane {2-methyl butane} | 00078-78-4 | 72.15 | 5.18 | 9.426 | 6.790 | 1,020.0 | 233.10 | 61 | 83 | 82 |

| Chemical Name | CAS Registry No. | Molecular Weight | Liquid Density ^d (lb/gal) | True Vapor Pressure at 60 °F (psia) | Constant ^b A dimensionless | Constant ^b B (°C) | Constant ^b C (°C) | Temperature Range ^{b,c} Minimum (°F) | Temperature Range ^{b,c} Maximum (°F) | Normal Boiling Point (°F) |
|---|------------------|------------------|--------------------------------------|-------------------------------------|---------------------------------------|------------------------------|------------------------------|---|---|---------------------------|
| Isopentene {2-methyl 2-butene} | 00513-35-9 | 70.13 | 5.53 | 6.210 | 6.922 | 1,098.6 | 233.26 | 37 | 159 | 100 |
| Isoprene {2-methyl 1,3-butadiene} | 00078-79-5 | 68.12 | 5.67 | 7.446 | 6.091 | 706.9 | 186.10 | 62 | 93 | 93 |
| Isopropyl alcohol {isopropanol} | 00067-63-0 | 60.10 | 6.52 ⁷⁷ | 0.443 | 7.736 | 1,357.4 | 197.34 | 134 | 193 | 180 |
| Isopropyl benzene {cumene} | 00098-82-8 | 120.19 | 7.19 | 0.048 | 6.929 | 1,455.8 | 207.20 | 158 | 308 | 305 |
| Isopropylbenzene (1-methyl-2) | 00527-84-4 | 134.22 | 7.32 | 0.017 | 7.417 | 1,880.5 | 236.27 | 178 | 355 | 350 |
| Methacrylonitrile {2-methyl 2-propenenitrile} | 00126-98-7 | 67.09 | 6.68 | 0.886 | 6.999 | 1,353.6 | 238.03 | -48 | 194 | 194 |
| Methane | 00074-82-8 | 16.04 | 3.53 ⁻²⁶⁰ | 4567 | 7.096 | 516.7 | 284.37 | -262 | -117 | -260 |
| Methyl acetate {methyl ester acetic acid} | 00079-20-9 | 74.08 | 7.80 | 2.703 | 7.079 | 1,164.4 | 220.46 | 35 | 133 | 134 |
| Methyl acrylate {methyl ester 2-propenoic acid} | 00096-33-3 | 86.09 | 7.96 | 1.058 | 7.198 | 1,338.7 | 229.63 | -47 | 176 | 177 |
| Methyl alcohol {methanol} | 00067-56-1 | 32.04 | 6.61 | 1.476 | 8.079 | 1,581.3 | 239.65 | 59 | 183 | 148 |
| Methyl ethyl ketone {2-butanone} | 00078-93-3 | 72.11 | 6.68 ⁷⁷ | 1.081 | 6.864 | 1,150.2 | 209.25 | 106 | 207 | 176 |
| Methyl isobutyl ketone | 00108-10-1 | 100.16 | 6.65 ⁷⁷ | 0.219 | 6.828 | 1,254.1 | 201.61 | 71 | 241 | 241 |
| Methyl methacrylate | 00080-62-6 | 100.12 | 7.88 | 0.416 | 8.253 | 1,945.6 | 265.58 | 102 | 192 | 213 |
| Methyl propyl ether | 00557-17-5 | 74.12 | 6.14 ⁵⁵ | 6.017 | 6.563 | 903.6 | 206.46 | 31 | 103 | 102 |

| Chemical Name | CAS Registry No. | Molecular Weight | Liquid Density ^d (lb/gal) | True Vapor Pressure at 60 °F (psia) | Constant ^b A dimensionless | Constant ^b B (°C) | Constant ^b C (°C) | Temperature Range ^{b,c} Minimum (°F) | Temperature Range ^{b,c} Maximum (°F) | Normal Boiling Point (°F) |
|--------------------------------|------------------|------------------|--------------------------------------|-------------------------------------|---------------------------------------|------------------------------|------------------------------|---|---|---------------------------|
| Methyl styrene (alpha) | 00098-83-9 | 118.18 | 7.60 | 0.024 | 6.924 | 1,486.9 | 202.40 | | | 329 |
| Methylcyclohexane | 00108-87-2 | 98.19 | 6.42 | 0.558 | 6.823 | 1,270.8 | 221.42 | 27 | 261 | 214 |
| Methylcyclopentane | 00096-37-7 | 84.16 | 6.25 | 1.738 | 6.863 | 1,186.1 | 226.04 | 59 | 163 | 161 |
| Methyldichlorosilane | 20156-50-7 | 115.03 | 8.91 | 5.718 | 7.028 | 1,167.8 | 240.70 | 34 | 106 | |
| Methylene chloride | 00075-09-2 | 84.93 | 11.07 | 5.640 | 7.412 | 1,327.0 | 252.68 | -40 | 104 | 104 |
| Methylhexane (2) | 00591-76-4 | 100.20 | 5.66 | 0.799 | 6.882 | 1,240.9 | 220.10 | 65 | 196 | 194 |
| Methylhexane (3) | 00589-34-4 | 100.20 | 5.72 | 0.744 | 6.874 | 1,243.8 | 219.63 | 68 | 199 | 197 |
| Methylpentane (2) | 00107-83-5 | 86.18 | 5.43 ⁷⁷ | 2.730 | 6.839 | 1,135.4 | 226.57 | 55 | 142 | 142 |
| Methyl-tert-butyl ether {MTBE} | 01634-04-4 | 88.15 | 6.18 | 3.226 | 6.867 | 1,116.1 | 224.74 | 125 | 431 | 131 |
| Morpholine | 00110-91-8 | 87.12 | 8.35 | 0.109 | 7.718 | 1,745.8 | 235.00 | 32 | 111 | 263 |
| Naphthalene | 00091-20-3 | 128.17 | 8.56 | 0.0024 | 7.146 | 1,831.6 | 211.82 | 177 | 354 | 422 |
| Nitrobenzene | 00098-95-3 | 123.11 | 10.05 | 0.0022 | 7.091 | 1,727.6 | 199.71 | 273 | 411 | 412 |
| Nitromethane | 00075-52-5 | 61.04 | 9.49 | 0.415 | 7.281 | 1,446.2 | 227.52 | 132 | 277 | 214 |
| Nonadecane (n) | 00629-92-5 | 268.52 | 6.56 | 3.64E-07 | 33.303 | 28,197 | 725.94 | 91 | 131 | 624 |
| Nonane (n) | 00111-84-2 | 128.26 | 5.99 | 0.037 | 6.700 | 1,492.9 | 217.26 | -64 | 94 | 303 |
| Octadecane (n) | 00593-45-3 | 254.49 | 6.4882 | 6.16E-07 | 7.207 | 2,069.0 | 161.22 | 346 | 602 | 592 |
| Octane (n) | 00111-65-9 | 114.23 | 5.8377 | 0.142 | 8.076 | 1,936.3 | 253.01 | -70 | 75 | 258 |
| Octanol (1) | 00111-87-5 | 130.23 | 6.9077 | 0.00061 | 9.352 | 2,603.4 | 224.35 | 68 | 176 | 383 |
| Octene (1) | 00111-66-0 | 112.21 | 5.97 | 0.196 | 6.933 | 1,353.5 | 212.76 | 113 | 252 | 251 |
| Pentachloroethane | 00076-01-7 | 202.29 | 14.02 | 0.040 | 6.643 | 1,342.3 | 196.51 | 77 | 324 | 324 |
| Pentadiene (1,2) | 00591-95-7 | 68.12 | 5.78 | 4.718 | 6.936 | 1,125.5 | 231.88 | -76 | -19 | 113 |
| Pentadiene (1,4) | 00591-93-5 | 68.12 | 5.52 | 10.06 | 7.035 | 1,108.2 | 241.05 | -110 | 65 | 79 |
| Pentadiene (2,3) | 00591-96-8 | 68.12 | 5.80 | 4.223 | 7.263 | 1,256.2 | 239.57 | -76 | -15 | 119 |
| Pentane (n) | 00109-66-0 | 72.15 | 5.23 | 6.884 | 6.864 | 1,070.6 | 232.70 | 24 | 155 | 97 |
| Pentene (1) | 00109-67-1 | 70.13 | 5.35 | 8.671 | 6.786 | 1,014.3 | 229.78 | 55 | 87 | 88 |
| Pentyne (1) | 00627-19-0 | 68.12 | 5.76 | 5.657 | 6.967 | 1,092.5 | 227.18 | -47 | 142 | 104 |

| Chemical Name | CAS Registry No. | Molecular Weight | Liquid Density ^d (lb/gal) | True Vapor Pressure at 60 °F (psia) | Constant ^b A dimensionless | Constant ^b B (°C) | Constant ^b C (°C) | Temperature Range ^{b,c} Minimum (°F) | Temperature Range ^{b,c} Maximum (°F) | Normal Boiling Point (°F) |
|--|------------------|------------------|--------------------------------------|-------------------------------------|---------------------------------------|------------------------------|------------------------------|---|---|---------------------------|
| Phenanthrene | 00085-01-8 | 178.23 | 8.18 | 3.37E-06 | 7.394 | 2,428.5 | 202.19 | 212 | 302 | 635 |
| Phenol | 00108-95-2 | 94.11 | 8.80 ¹¹³ | 0.003 | 7.122 | 1,509.7 | 174.20 | 225 | 359 | 359 |
| Phosgene | 00075-44-5 | 98.92 | 11.45 ⁷⁷ | 19.43 | 7.146 | 1,072.7 | 243.30 | 47 | 345 | 46 |
| Picoline (3) {3-methyl pyridine} | 00108-99-6 | 93.13 | 7.98 | 0.064 | 7.054 | 1,484.3 | 211.54 | 165 | 364 | 291 |
| Propane | 00074-98-6 | 44.10 | 4.12 ⁷⁷ | 111 | 6.858 | 819.3 | 248.73 | -45 | 117 | -44 |
| Propanethiol (1) | 00107-03-9 | 76.16 | 7.02 | 1.943 | 6.929 | 1,183.4 | 224.63 | 76 | 216 | 154 |
| Propanethiol (2) | 00075-33-2 | 76.16 | 6.80 | 3.590 | 6.877 | 1,113.9 | 226.16 | 51 | 186 | 131 |
| Propyl alcohol (n) {propanol (1)} | 00071-23-8 | 60.10 | 6.67 ⁷⁷ | 0.218 | 8.189 | 1,690.9 | 221.35 | 67 | 207 | 207 |
| Propyl nitrate (n) {propyl ester nitric acid} | 00627-13-4 | 105.09 | 8.80 | 0.261 | 6.955 | 1,294.4 | 206.70 | 32 | 158 | 231 |
| Propylamine (n) {1-propanamine} | 00107-10-8 | 59.11 | 5.99 | 3.990 | 6.926 | 1,044.0 | 210.84 | 73 | 172 | 120 |
| Propylene {propene} | 00115-07-1 | 42.08 | 4.22 | 132 | 6.850 | 795.8 | 248.27 | -161 | -53 | -54 |
| Propylene glycol (1,2) {1,2-propanediol} | 00057-55-6 | 76.09 | 8.65 | 0.00094 | 8.208 | 2,085.9 | 203.54 | | | 368 |
| Propylene oxide | 00075-56-9 | 58.08 | 7.17 ³² | 7.101 | 6.970 | 1,065.3 | 226.28 | -100 | 94 | 95 |
| Pyridine | 00110-86-1 | 79.10 | 8.20 | 0.233 | 7.038 | 1,371.4 | 214.65 | 153 | 307 | 240 |
| Resorcinol | 00108-46-3 | 110.11 | 10.61 ⁷⁷ | 6.65E-06 | 8.398 | 2,687.2 | 210.99 | 305 | 530 | 532 |
| Styrene | 00100-42-5 | 104.15 | 7.56 | 0.066 | 7.095 | 1,525.1 | 216.77 | 86 | 293 | 295 |
| Tetrachloroethane (1,1,1,2) | 00630-20-6 | 167.85 | 12.86 | 0.133 | 6.906 | 1,370.4 | 210.25 | 139 | 266 | 271 |
| Tetrachloroethane (1,1,2,2) | 00079-34-5 | 167.85 | 13.32 | 0.037 | 6.091 | 959.6 | 149.78 | 77 | 266 | 295 |
| Tetrachloroethylene | 00127-18-4 | 165.83 | 13.54 | 0.213 | 7.056 | 1,440.8 | 223.98 | 82 | 226 | 250 |
| Tetraethyllead | 00078-00-2 | 323.40 | 13.79 | 0.0031 | 7.898 | 1,984.4 | 212.64 | 40 | 130 | 392 |
| Tetrahydrofuran | 00109-99-9 | 72.11 | 7.42 | 2.039 | 6.996 | 1,202.9 | 226.33 | 74 | 211 | 151 |

| Chemical Name | CAS Registry No. | Molecular Weight | Liquid Density ^d (lb/gal) | True Vapor Pressure at 60 °F (psia) | Constant ^b A dimensionless | Constant ^b B (°C) | Constant ^b C (°C) | Temperature Range ^{b,c} Minimum (°F) | Temperature Range ^{b,c} Maximum (°F) | Normal Boiling Point (°F) |
|---|------------------|------------------|--------------------------------------|-------------------------------------|---------------------------------------|------------------------------|------------------------------|---|---|---------------------------|
| Toluene | 00108-88-3 | 92.14 | 7.24 | 0.331 | 7.017 | 1,377.6 | 222.64 | 32 | 122 | 231 |
| Trichloroethane (1,1,1) | 00071-55-6 | 133.40 | 11.18 | 1.650 | 8.761 | 2,210.2 | 308.05 | 22 | 62 | 165 |
| Trichloroethane (1,1,2) | 00079-00-5 | 133.40 | 12.02 | 0.245 | 6.945 | 1,310.3 | 208.74 | 122 | 237 | 237 |
| Trichloroethylene | 00079-01-6 | 131.39 | 12.22 | 0.817 | 6.429 | 974.5 | 187.34 | 64 | 188 | 189 |
| Trichloropropane (1,2,3) | 00096-18-4 | 147.43 | 11.59 | 0.031 | 7.532 | 1,818.9 | 232.52 | 48 | 316 | 313 |
| Tridecane (<i>n</i>) | 00629-50-5 | 184.36 | 6.31 | 2.46E-04 | 7.003 | 1,689.1 | 174.28 | 283 | 457 | 453 |
| Trimethylbenzene (1,2,4) | 00095-63-6 | 120.19 | 7.31 | 0.020 | 7.044 | 1,573.3 | 208.56 | 126 | 388 | 337 |
| Trimethylchlorosilane {chlorotrimethylsilane} | 00075-77-4 | 108.64 | 7.15 ⁷⁷ | 3.068 | 6.951 | 1,191.0 | 235.15 | 37 | 132 | 136 |
| Trimethylpentane (2,2,3) | 00564-02-3 | 114.23 | 5.74 ⁷⁷ | 0.378 | 6.825 | 1,294.9 | 218.42 | | | 230 |
| Trimethylpentane (2,3,3) | 00560-21-4 | 114.23 | 6.06 | 0.317 | 6.844 | 1,328.1 | 220.38 | | | 238 |
| Trimethylpentane (2,3,4) | 00565-75-3 | 114.23 | 6.00 | 0.314 | 7.031 | 1,420.7 | 228.53 | -59 | 308 | 237 |
| Undecane (<i>n</i>) | 01120-21-4 | 156.31 | 6.18 | 0.0035 | 6.977 | 1,572.5 | 188.02 | 220 | 387 | 383 |
| Vinyl acetate {acetic acid ethenyl ester} | 00108-05-4 | 86.09 | 7.78 | 1.396 | 7.215 | 1,299.1 | 226.97 | 71 | 162 | 163 |
| Vinylidene chloride {1,1-dichloroethene} | 00075-35-4 | 96.94 | 10.13 | 8.096 | 6.983 | 1,104.7 | 237.75 | -19 | 90 | 88 |
| Xylene (<i>m</i>) {1,3-dimethylbenzene} | 00108-38-3 | 106.17 | 7.21 | 0.090 | 7.009 | 1,462.3 | 215.11 | 82 | 331 | 283 |
| Xylene (<i>o</i>) {1,2-dimethylbenzene} | 00095-47-6 | 106.17 | 7.35 ⁵⁰ | 0.071 | 6.999 | 1,474.7 | 213.69 | 90 | 342 | 291 |

| Chemical Name | CAS Registry No. | Molecular Weight | Liquid Density ^d (lb/gal) | True Vapor Pressure at 60 °F (psia) | Constant ^b A dimensionless | Constant ^b B (°C) | Constant ^b C (°C) | Temperature Range ^{b,c} Minimum (°F) | Temperature Range ^{b,c} Maximum (°F) | Normal Boiling Point (°F) |
|--------------------------------------|------------------|------------------|--------------------------------------|-------------------------------------|---------------------------------------|------------------------------|------------------------------|---|---|---------------------------|
| Xylene (p) {1,4-dimethyl benzene} | 00106-42-3 | 106.17 | 7.19 | 0.097 | 7.021 | 1,474.4 | 217.77 | 56 | 355 | 281 |

NOTE: Synonyms are shown in braces { }. Prefixes are shown in parentheses ().

^a Reference 22.

^b **Antoine's Equation** Vapor pressure P_{VA} in psia = $(0.019337)10^{\left[A - \frac{B}{(T_{LA}-32)^5 + C}\right]}$ where T_{LA} is the temperature in °F.

^c Use of this equation for temperature outside the indicated temperature range may result in loss of accuracy.

^d The superscript denotes the temperature in °F; if no superscript is given the density is for 68°F.

Table 7.1-4. Height Of The Liquid Heel And Vapor Space Under A Landed Floating Roof ^a

| Scenario | | Expression for height of the vapor space (h_v) |
|--|---|--|
| <u>General Expression</u> | <u>Slope convention:</u> s is expressed in ft/ft; positive for cone down, negative for cone up. | $h_v = \left(h_d + \frac{sD}{6} \right) - h_{le}$ |
| <u>Full liquid heel</u> | $h_{le} = \left(h_l + \frac{sD}{6} \right)$ | $h_v = h_d - h_l$ |
| <u>Partial liquid heel</u> (this condition may occur after normal pumpout of a tank with a cone-down bottom, or be created during the tank cleaning process of any tank that had a full liquid heel after normal pumpout) | h_p = the vertical distance from the bottom of the shell down to the liquid surface in a cone-down bottom. h_{le} = the height that would result from spreading the available volatile materials evenly over a flat tank bottom. $h_{le} = \left[\left(\frac{\text{volume of heel, ft}^3}{\pi D^2 / 4} \right) + \left(\frac{0.01 \text{ in.}}{12 \text{ in./ft}} \right) \right]$ | volume of heel, $\text{ft}^3 = \frac{\left(\frac{\pi D^2}{12} \right) \left(\frac{sD}{2} - h_p \right)^3}{\left(\frac{sD}{2} \right)^2}$ $h_v = \left(h_d + \frac{sD}{6} \right) - \left[\left(\frac{\text{volume of heel, ft}^3}{\pi D^2 / 4} \right) + \left(\frac{0.01 \text{ in.}}{12 \text{ in./ft}} \right) \right]$ |
| No significant amount of <u>volatile material remaining</u> (drain dry tanks or any tank after sludge removal) | $h_{le} = 0$ | $h_v = \left(h_d + \frac{sD}{6} \right)$ |
| <u>Flat bottom</u> (including slight cone-up bottoms)* | $s = 0$ $h_{le} = h_l$ | $h_v = h_d - h_{le} \{ = h_d - h_l, \text{ given } s = 0 \}$ |

where:

h_d = deck leg height at the tank shell, ft

h_l = height of liquid at the tank shell, ft

h_{le} = effective liquid height during roof landing, ft

h_p = the vertical distance from the bottom of the shell down to the liquid surface in a cone-down bottom, ft

h_v = vapor space height under landed floating roof, ft

s = tank cone bottom slope, ft/ft

These variables are illustrated schematically in Figures 7.1-23 and 7.1-24.

^a Reference 23.

*A slight cone-up bottom might have an upward slope on the order of 1:120.

Table 7.1-5. LEL Values For Selected Compounds ^a

| Compound | LEL (volume percent in air) |
|--------------|--------------------------------|
| Heptane (C7) | 1.05 |
| Hexane (C6) | 1.1 |
| Pentane (C5) | 1.5 |
| Butane (C4) | 1.9 |
| Propane (C3) | 2.1 |
| Ethane (C2) | 3.0 |
| Methane (C1) | 5.0 |

^a Reference 28.

Table 7.1-6. Paint Solar Absorptance^a

| Surface Color | Shade or Type | Reflective Condition (see Note 1) Good | Reflective Condition (see Note 1) Average | Reflective Condition (see Note 1) Aged |
|--------------------------|------------------------|--|---|--|
| White | | 0.17 | 0.25 | 0.34 |
| Aluminum | Specular | 0.39 | 0.44 | 0.49 |
| Aluminum | Diffuse | 0.60 | 0.64 | 0.68 |
| Beige/Cream | | 0.35 | 0.42 | 0.49 |
| Black | | 0.97 | 0.97 | 0.97 |
| Brown | | 0.58 | 0.62 | 0.67 |
| Gray | Light | 0.54 | 0.58 | 0.63 |
| Gray | Medium | 0.68 | 0.71 | 0.74 |
| Green | Dark | 0.89 | 0.90 | 0.91 |
| Red | Primer | 0.89 | 0.90 | 0.91 |
| Rust | red iron oxide | 0.38 | 0.44 | 0.50 |
| Tan | | 0.43 | 0.49 | 0.55 |
| Aluminum (see Note 2) | mill finish, unpainted | 0.10 | 0.12 | 0.15 |

Notes:

NOTE 1 Reflective condition definitions:

Good: For paint, paint is in good condition.

Average: For mill-finish aluminum, surface is oxidized but still bright. The value given in each case is the average of the Good and the Aged values for that case, and does not represent new data.

Aged: For paint, paint is noticeably faded and dull; for mill-finish aluminum, surface is dull.

NOTE 2 This refers to aluminum as the base metal, rather than aluminum-colored paint.

^a Reference 22. If specific information is not available, a white shell and roof, with the paint in good condition, can be assumed to represent the most common or typical tank surface in use. If the tank roof and shell are painted a different color, α is determined from $\alpha = (\alpha_R + \alpha_S)/2$; where α_R is the tank roof paint solar absorptance and α_S is the tank shell paint solar absorptance.

Table 7.1-7. Meteorological Data (T_{AX} , T_{AN} , V , I , P_A) For Selected U.S. Locations ^a

| Location | Symbol | Units | Jan | Feb | Mar | Apr | May | Jun | Jul | Aug | Sep | Oct | Nov | Dec | Annual |
|----------------|----------|--------------------------|------|------|------|------|------|-------|-------|-------|------|------|------|------|--------|
| Birmingham, AL | T_{AN} | °F | 35 | 37.5 | 44.1 | 51.7 | 60.6 | 68.1 | 71.7 | 71.1 | 64.7 | 53.3 | 43.3 | 36.7 | 53.2 |
| Birmingham, AL | T_{AX} | °F | 53.7 | 57.8 | 65.9 | 73.9 | 80.9 | 86.8 | 90 | 89.8 | 84.5 | 74.7 | 64.2 | 55.3 | 73.1 |
| Birmingham, AL | V | mi/hr | 7.2 | 7.4 | 7.8 | 7.4 | 6.3 | 5.4 | 5.1 | 4.7 | 5.4 | 5.4 | 6 | 6.7 | 6.3 |
| Birmingham, AL | I | Btu/ft ² /day | 769 | 1013 | 1382 | 1720 | 1884 | 1928 | 1889 | 1760 | 1504 | 1212 | 890 | 699 | 1388 |
| Birmingham, AL | P_A | psia | | | | | | | | | | | | | 14.37 |
| Huntsville, AL | T_{AN} | °F | 32.7 | 35.2 | 42.1 | 50.6 | 59.6 | 67.2 | 70.3 | 69.2 | 62.6 | 51.1 | 41.2 | 34.5 | 51.4 |
| Huntsville, AL | T_{AX} | °F | 50.3 | 54.4 | 63.1 | 72.3 | 79.9 | 86.3 | 88.9 | 89.2 | 83.7 | 73.4 | 61.6 | 52.1 | 71.3 |
| Huntsville, AL | V | mi/hr | 8.3 | 8.3 | 8.9 | 8.5 | 7.4 | 5.8 | 4.9 | 4.9 | 5.8 | 6.3 | 7.2 | 7.8 | 7.2 |
| Huntsville, AL | I | Btu/ft ² /day | 714 | 949 | 1314 | 1690 | 1868 | 1973 | 1948 | 1823 | 1508 | 1191 | 835 | 656 | 1372 |
| Huntsville, AL | P_A | psia | | | | | | | | | | | | | 14.36 |
| Mobile, AL | T_{AN} | °F | 41.4 | 43.8 | 49.7 | 56.3 | 64.7 | 71 | 73.3 | 73.1 | 68.9 | 58.4 | 48.3 | 42.4 | 57.6 |
| Mobile, AL | T_{AX} | °F | 60.8 | 64.2 | 70.4 | 76.7 | 84 | 88.3 | 90.1 | 89.9 | 86.4 | 78.5 | 69.5 | 62.1 | 76.7 |
| Mobile, AL | V | mi/hr | 8.5 | 8.5 | 8.7 | 8.3 | 7.4 | 6 | 5.4 | 5.4 | 6.7 | 6.9 | 7.2 | 7.8 | 7.2 |
| Mobile, AL | I | Btu/ft ² /day | 865 | 1114 | 1446 | 1774 | 1955 | 1925 | 1876 | 1767 | 1557 | 1304 | 1024 | 818 | 1452 |
| Mobile, AL | P_A | psia | | | | | | | | | | | | | 14.58 |
| Montgomery, AL | T_{AN} | °F | 37.1 | 39.9 | 46.1 | 52.6 | 61.8 | 68.9 | 72.2 | 71.7 | 66.2 | 54.4 | 44 | 38 | 54.4 |
| Montgomery, AL | T_{AX} | °F | 57.7 | 62 | 69.4 | 76.6 | 83.9 | 89.4 | 91.8 | 91.5 | 86.9 | 77.7 | 67.9 | 59.1 | 76.2 |
| Montgomery, AL | V | mi/hr | 7.2 | 7.4 | 7.6 | 6.5 | 5.8 | 4.9 | 4.7 | 4.7 | 5.6 | 5.4 | 5.8 | 6.7 | 6 |
| Montgomery, AL | I | Btu/ft ² /day | 823 | 1076 | 1421 | 1766 | 1952 | 1951 | 1943 | 1781 | 1530 | 1223 | 950 | 749 | 1430 |
| Montgomery, AL | P_A | psia | | | | | | | | | | | | | 14.59 |
| Phoenix, AZ | T_{AN} | °F | 46.5 | 49.5 | 54 | 60.1 | 69.8 | 78.1 | 84.3 | 83.4 | 78.1 | 65.4 | 53.3 | 45.6 | 64 |
| Phoenix, AZ | T_{AX} | °F | 66.7 | 69.8 | 76.1 | 83.6 | 93.8 | 102.6 | 105.4 | 103.6 | 99.6 | 87.8 | 75.1 | 65.6 | 85.8 |
| Phoenix, AZ | V | mi/hr | 4.9 | 5.6 | 6.3 | 6.9 | 6.9 | 6.7 | 6.9 | 6.7 | 6 | 5.6 | 4.9 | 4.7 | 6 |
| Phoenix, AZ | I | Btu/ft ² /day | 1058 | 1335 | 1774 | 2248 | 2495 | 2606 | 2379 | 2144 | 1910 | 1542 | 1172 | 967 | 1802 |
| Phoenix, AZ | P_A | psia | | | | | | | | | | | | | 14.11 |
| Prescott, AZ | T_{AN} | °F | 26.8 | 29.5 | 33.5 | 38.9 | 48 | 55.9 | 63.3 | 61.9 | 54.9 | 42.7 | 32.3 | 26.2 | 42.8 |
| Prescott, AZ | T_{AX} | °F | 51.4 | 54.4 | 60 | 66.4 | 76.5 | 85.6 | 89.2 | 86.5 | 82.2 | 71.4 | 60.1 | 51.1 | 69.6 |

| | | | | | | | | | | | | | | | |
|-----------------|----------|--------------------------|------|------|------|------|------|------|------|------|------|------|------|------|-------|
| Prescott, AZ | V | mi/hr | 6.5 | 7.2 | 8.1 | 8.9 | 8.7 | 8.7 | 7.4 | 6.7 | 6.9 | 6.9 | 6.5 | 6.3 | 7.4 |
| Prescott, AZ | I | Btu/ft ² /day | 982 | 1245 | 1694 | 2156 | 2415 | 2571 | 2171 | 1903 | 1805 | 1493 | 1130 | 901 | 1705 |
| Prescott, AZ | P_A | psia | | | | | | | | | | | | | 12.24 |
| Tucson, AZ | T_{AN} | °F | 40.7 | 43.1 | 47 | 52.4 | 61.6 | 70.4 | 75.7 | 74.4 | 70.1 | 58.4 | 47 | 40 | 56.8 |
| Tucson, AZ | T_{AX} | °F | 65.8 | 68.4 | 74.2 | 81.7 | 91.7 | 99.9 | 99.6 | 97.3 | 94.7 | 85.1 | 74.1 | 65 | 83.1 |
| Tucson, AZ | V | mi/hr | 6.9 | 7.4 | 7.8 | 8.3 | 8.1 | 8.1 | 7.8 | 7.4 | 7.6 | 7.6 | 7.2 | 6.9 | 7.6 |
| Tucson, AZ | I | Btu/ft ² /day | 1110 | 1370 | 1840 | 2279 | 2510 | 2582 | 2198 | 2007 | 1886 | 1595 | 1249 | 1033 | 1805 |
| Tucson, AZ | P_A | psia | | | | | | | | | | | | | 13.4 |
| Fort Smith, AR | T_{AN} | °F | 30.7 | 34.3 | 41.8 | 50.5 | 60.4 | 68.4 | 72.4 | 71.4 | 63 | 51.6 | 41 | 32.8 | 51.5 |
| Fort Smith, AR | T_{AX} | °F | 49.4 | 55.3 | 63.7 | 73 | 79.8 | 87.1 | 92.3 | 92.8 | 84.4 | 74.3 | 61.8 | 51.6 | 72.1 |
| Fort Smith, AR | V | mi/hr | 7.6 | 8.1 | 8.7 | 8.3 | 6.9 | 6 | 5.4 | 5.6 | 6 | 6.3 | 7.2 | 7.6 | 6.9 |
| Fort Smith, AR | I | Btu/ft ² /day | 738 | 977 | 1299 | 1674 | 1808 | 1991 | 2117 | 1918 | 1522 | 1177 | 811 | 674 | 1392 |
| Fort Smith, AR | P_A | psia | | | | | | | | | | | | | 14.46 |
| Little Rock, AR | T_{AN} | °F | 33.3 | 36.3 | 43.8 | 52.4 | 61.6 | 69.7 | 73.2 | 72.2 | 64.4 | 53.1 | 42.9 | 35 | 53.2 |
| Little Rock, AR | T_{AX} | °F | 50.6 | 55.5 | 63.7 | 73.1 | 80.8 | 88.1 | 91.8 | 92.2 | 84.9 | 74.4 | 62.1 | 52.3 | 72.5 |
| Little Rock, AR | V | mi/hr | 7.8 | 7.8 | 8.7 | 8.5 | 7.2 | 6.3 | 6 | 5.6 | 6.3 | 6 | 7.2 | 7.6 | 7.2 |
| Little Rock, AR | I | Btu/ft ² /day | 717 | 970 | 1302 | 1686 | 1820 | 2008 | 2009 | 1879 | 1534 | 1171 | 814 | 656 | 1380 |
| Little Rock, AR | P_A | psia | | | | | | | | | | | | | 14.56 |
| Arcata, CA | T_{AN} | °F | 40.7 | 41.4 | 41.1 | 42.4 | 46 | 48.4 | 51.4 | 51.4 | 48.3 | 45.1 | 42.5 | 40.2 | 44.9 |
| Arcata, CA | T_{AX} | °F | 55.1 | 55.6 | 55.5 | 56.2 | 58.9 | 61.1 | 62.2 | 63.2 | 63.2 | 61.9 | 57.5 | 54.9 | 58.8 |
| Arcata, CA | V | mi/hr | 6.7 | 6.7 | 7.2 | 7.2 | 7.2 | 7.2 | 6 | 5.6 | 5.1 | 5.4 | 5.8 | 6.9 | 6.3 |
| Arcata, CA | I | Btu/ft ² /day | 527 | 730 | 1139 | 1516 | 1822 | 1946 | 1809 | 1573 | 1327 | 971 | 613 | 460 | 1203 |
| Arcata, CA | P_A | psia | | | | | | | | | | | | | 14.59 |
| Bakersfield, CA | T_{AN} | °F | 40.3 | 43.7 | 46.9 | 49.8 | 57.8 | 64.2 | 70.7 | 69.3 | 64.5 | 55.3 | 45.3 | 39.7 | 54 |
| Bakersfield, CA | T_{AX} | °F | 56.9 | 62.9 | 69 | 74.1 | 83.3 | 90.6 | 96.9 | 95.7 | 90.4 | 79 | 65.7 | 57.3 | 76.8 |
| Bakersfield, CA | V | mi/hr | 4.9 | 5.6 | 6 | 6.9 | 7.4 | 7.6 | 6.9 | 6.7 | 6 | 5.4 | 4.7 | 4.9 | 6 |
| Bakersfield, CA | I | Btu/ft ² /day | 717 | 1031 | 1543 | 2010 | 2358 | 2570 | 2500 | 2293 | 1911 | 1411 | 952 | 696 | 1666 |
| Bakersfield, CA | P_A | psia | | | | | | | | | | | | | 14.43 |
| Bishop, CA | T_{AN} | °F | 24 | 27.4 | 32.1 | 36.8 | 45.1 | 51.9 | 57.7 | 54.8 | 47.6 | 38.5 | 28.3 | 22.9 | 38.9 |
| Bishop, CA | T_{AX} | °F | 53 | 56.2 | 64.5 | 70.5 | 80.8 | 90.4 | 97.5 | 95.5 | 87.6 | 75.2 | 61.9 | 52.5 | 73.8 |

| | | | | | | | | | | | | | | | |
|--------------------|----------|--------------------------|------|------|------|------|------|------|-------|-------|------|------|------|------|-------|
| Bishop, CA | V | mi/hr | 7.2 | 8.1 | 9.4 | 10.1 | 9.2 | 8.3 | 7.8 | 8.1 | 7.6 | 7.8 | 7.4 | 6.9 | 8.1 |
| Bishop, CA | I | Btu/ft ² /day | 882 | 1186 | 1683 | 2080 | 2378 | 2564 | 2487 | 2278 | 1925 | 1457 | 1046 | 824 | 1732 |
| Bishop, CA | P_A | psia | | | | | | | | | | | | | 12.68 |
| Daggett, CA | T_{AN} | °F | 37.5 | 41.2 | 46.2 | 51.3 | 60.6 | 68 | 74.7 | 73.6 | 66.5 | 55.3 | 43.2 | 36.1 | 54.5 |
| Daggett, CA | T_{AX} | °F | 60.8 | 64.4 | 71.7 | 78.3 | 88.9 | 98 | 104.6 | 103.1 | 95.7 | 82.5 | 69.1 | 59.6 | 81.4 |
| Daggett, CA | V | mi/hr | 8.1 | 9.4 | 11.4 | 13.9 | 14.1 | 13.6 | 11.6 | 11 | 10.1 | 9.6 | 8.5 | 7.6 | 10.7 |
| Daggett, CA | I | Btu/ft ² /day | 992 | 1270 | 1756 | 2197 | 2492 | 2656 | 2470 | 2259 | 1972 | 1544 | 1142 | 921 | 1806 |
| Daggett, CA | P_A | psia | | | | | | | | | | | | | 13.71 |
| Fresno, CA | T_{AN} | °F | 39.9 | 43.1 | 46.5 | 49.6 | 56.9 | 62.4 | 68.3 | 66.7 | 62.2 | 53.7 | 44.6 | 39.4 | 52.8 |
| Fresno, CA | T_{AX} | °F | 55 | 61.1 | 67.4 | 73.1 | 83.2 | 90.9 | 97.7 | 96.3 | 90.7 | 78.5 | 64.7 | 55.1 | 76.1 |
| Fresno, CA | V | mi/hr | 4.3 | 5.1 | 5.8 | 7.4 | 8.3 | 8.5 | 7.6 | 6.9 | 6 | 4.7 | 4 | 4.3 | 6 |
| Fresno, CA | I | Btu/ft ² /day | 638 | 973 | 1519 | 2002 | 2368 | 2573 | 2534 | 2290 | 1895 | 1383 | 889 | 602 | 1639 |
| Fresno, CA | P_A | psia | | | | | | | | | | | | | 14.52 |
| Long Beach, CA | T_{AN} | °F | 47.6 | 49 | 51.5 | 53.6 | 58.2 | 61.4 | 64.7 | 65.3 | 63.5 | 58.8 | 51.8 | 46.8 | 56 |
| Long Beach, CA | T_{AX} | °F | 66.5 | 65.9 | 67.7 | 70.4 | 72.6 | 75.7 | 80.3 | 82.5 | 81 | 76 | 71.4 | 66 | 73 |
| Long Beach, CA | V | mi/hr | 4.5 | 5.1 | 5.6 | 6.3 | 6 | 6 | 6 | 5.8 | 5.4 | 4.7 | 4.3 | 4.3 | 5.4 |
| Long Beach, CA | I | Btu/ft ² /day | 894 | 1109 | 1548 | 1958 | 2066 | 2207 | 2264 | 2156 | 1767 | 1327 | 1039 | 843 | 1598 |
| Long Beach, CA | P_A | psia | | | | | | | | | | | | | 14.68 |
| Los Angeles AP, CA | T_{AN} | °F | 50 | 50.9 | 52.4 | 54.1 | 57.8 | 61 | 64 | 64.6 | 63.4 | 59.6 | 54 | 49.7 | 56.8 |
| Los Angeles AP, CA | T_{AX} | °F | 64.9 | 64.4 | 64.7 | 66.5 | 68.5 | 71 | 73.9 | 75.3 | 74.5 | 72.3 | 69.3 | 64.8 | 69.2 |
| Los Angeles AP, CA | V | mi/hr | 6.5 | 7.6 | 8.1 | 8.7 | 8.1 | 8.1 | 8.1 | 7.6 | 7.4 | 6.7 | 6.3 | 6.5 | 7.4 |
| Los Angeles AP, CA | I | Btu/ft ² /day | 895 | 1115 | 1537 | 1988 | 2045 | 2140 | 2117 | 2037 | 1662 | 1298 | 1036 | 834 | 1559 |
| Los Angeles AP, CA | P_A | psia | | | | | | | | | | | | | 14.63 |
| Redding, CA | T_{AN} | °F | 38.2 | 40.6 | 43.7 | 46.6 | 55 | 62 | 67 | 63.8 | 58.7 | 50.4 | 41.8 | 37.6 | 50.4 |
| Redding, CA | T_{AX} | °F | 55 | 58.3 | 64.9 | 69.6 | 80.4 | 89.3 | 98.1 | 96.2 | 90.4 | 77.1 | 62.5 | 54 | 74.7 |
| Redding, CA | V | mi/hr | 5.8 | 6.5 | 6.7 | 6.7 | 6.7 | 6.9 | 6 | 5.6 | 5.4 | 5.6 | 4.9 | 6 | 6 |
| Redding, CA | I | Btu/ft ² /day | 577 | 856 | 1354 | 1772 | 2198 | 2464 | 2526 | 2246 | 1786 | 1209 | 721 | 497 | 1517 |
| Redding, CA | P_A | psia | | | | | | | | | | | | | 14.43 |

| | | | | | | | | | | | | | | | |
|----------------------|----------|--------------------------|------|------|------|------|------|------|------|------|------|------|------|------|-------|
| Sacramento, CA | T_{AN} | °F | 40 | 42.7 | 44.7 | 46.8 | 52.1 | 56.5 | 59.1 | 58.9 | 56.4 | 50.7 | 43.3 | 39.5 | 49.2 |
| Sacramento, CA | T_{AX} | °F | 54.3 | 59.6 | 65.4 | 70.3 | 79.3 | 86.1 | 91.4 | 90.9 | 87.4 | 77.1 | 63.8 | 54.4 | 73.3 |
| Sacramento, CA | V | mi/hr | 5.6 | 6 | 6.7 | 7.4 | 7.6 | 8.1 | 7.6 | 6.9 | 5.8 | 5.4 | 4.9 | 5.8 | 6.5 |
| Sacramento, CA | I | Btu/ft ² /day | 563 | 877 | 1409 | 1891 | 2249 | 2510 | 2514 | 2239 | 1823 | 1269 | 790 | 518 | 1555 |
| Sacramento, CA | P_A | psia | | | | | | | | | | | | | 14.68 |
| San Diego, CA | T_{AN} | °F | 50.1 | 51.6 | 53.9 | 56.2 | 59.8 | 62.3 | 65.4 | 66.9 | 65.4 | 61 | 54.4 | 49.5 | 58 |
| San Diego, CA | T_{AX} | °F | 64.5 | 64.3 | 65 | 66.6 | 67.9 | 70.1 | 73.4 | 75.6 | 75 | 72 | 68.6 | 64.2 | 68.9 |
| San Diego, CA | V | mi/hr | 5.4 | 6.3 | 6.7 | 7.4 | 7.2 | 7.4 | 7.2 | 6.9 | 6.7 | 5.8 | 4.9 | 4.9 | 6.5 |
| San Diego, CA | I | Btu/ft ² /day | 990 | 1206 | 1604 | 1990 | 1993 | 2135 | 2127 | 2087 | 1774 | 1367 | 1107 | 922 | 1608 |
| San Diego, CA | P_A | psia | | | | | | | | | | | | | 14.69 |
| San Francisco AP, CA | T_{AN} | °F | 45.2 | 47.2 | 48.3 | 49.4 | 52.2 | 54 | 55.8 | 56.6 | 56.2 | 53.9 | 49.4 | 45.6 | 51.1 |
| San Francisco AP, CA | T_{AX} | °F | 55.9 | 58.6 | 61.4 | 63.3 | 66.3 | 69.2 | 70.6 | 71.6 | 72.5 | 69.4 | 62.3 | 56.2 | 64.8 |
| San Francisco AP, CA | V | mi/hr | 6.9 | 8.3 | 10.3 | 12.5 | 13.4 | 14.1 | 12.8 | 12.3 | 10.7 | 9.2 | 7.4 | 7.4 | 10.5 |
| San Francisco AP, CA | I | Btu/ft ² /day | 666 | 896 | 1353 | 1813 | 1981 | 2123 | 2023 | 1747 | 1488 | 1124 | 798 | 619 | 1386 |
| San Francisco AP, CA | P_A | psia | | | | | | | | | | | | | 14.69 |
| Santa Barbara, CA | T_{AN} | °F | 41.9 | 44.6 | 46.8 | 48.2 | 52.1 | 54.8 | 57.9 | 58 | 56.3 | 51.7 | 45.4 | 41.1 | 49.9 |
| Santa Barbara, CA | T_{AX} | °F | 63.7 | 63.8 | 64.8 | 67.2 | 69 | 70.7 | 73.2 | 74.2 | 73.9 | 71.9 | 68.7 | 63.7 | 68.8 |
| Santa Barbara, CA | V | mi/hr | 4.5 | 5.6 | 5.8 | 6.7 | 6.5 | 6 | 6 | 5.6 | 5.1 | 4.7 | 4.3 | 4.3 | 5.4 |
| Santa Barbara, CA | I | Btu/ft ² /day | 907 | 1116 | 1543 | 1968 | 2115 | 2184 | 2153 | 2107 | 1749 | 1346 | 1051 | 839 | 1590 |
| Santa Barbara, CA | P_A | psia | | | | | | | | | | | | | 14.69 |
| Santa Maria, CA | T_{AN} | °F | 41.1 | 43 | 44.2 | 44.6 | 48.2 | 50.9 | 54 | 54.3 | 53 | 49.3 | 44 | 40.2 | 47.2 |
| Santa Maria, CA | T_{AX} | °F | 63.2 | 63.6 | 64.9 | 66.5 | 68.3 | 69.9 | 71.7 | 72.4 | 73.3 | 72.2 | 68.5 | 63.1 | 68.1 |
| Santa Maria, CA | V | mi/hr | 6 | 6.7 | 7.6 | 8.3 | 8.3 | 7.8 | 6.5 | 6.3 | 5.8 | 6 | 6 | 6 | 6.7 |
| Santa Maria, CA | I | Btu/ft ² /day | 892 | 1109 | 1563 | 2010 | 2253 | 2358 | 2261 | 2111 | 1784 | 1386 | 1036 | 828 | 1633 |
| Santa Maria, CA | P_A | psia | | | | | | | | | | | | | 14.56 |
| Stockton, CA | T_{AN} | °F | 39.5 | 42.2 | 44.3 | 47 | 52.8 | 57.6 | 60.9 | 60.4 | 57.5 | 50.9 | 43.1 | 38.9 | 49.6 |
| Stockton, CA | T_{AX} | °F | 54.5 | 60.4 | 66.5 | 71.7 | 80.6 | 87.8 | 93.4 | 92.3 | 88.5 | 78 | 64.6 | 54.7 | 74.4 |

| | | | | | | | | | | | | | | | |
|----------------------|-----------------------|--------------------------|------|------|------|------|------|------|------|------|------|------|------|------|-------|
| Stockton, CA | <i>V</i> | mi/hr | 6.7 | 7.2 | 7.6 | 8.9 | 9.6 | 10.1 | 8.9 | 8.3 | 7.4 | 6.5 | 5.8 | 6.9 | 7.8 |
| Stockton, CA | <i>I</i> | Btu/ft ² /day | 573 | 907 | 1445 | 1879 | 2251 | 2525 | 2510 | 2256 | 1844 | 1308 | 824 | 552 | 1573 |
| Stockton, CA | <i>P_A</i> | psia | | | | | | | | | | | | | 14.68 |
| Alamosa, CO | <i>T_{AN}</i> | °F | 0.5 | 7.4 | 18 | 25.4 | 34.8 | 41.4 | 47.7 | 46.7 | 37.4 | 25.4 | 12.7 | 2 | 24.9 |
| Alamosa, CO | <i>T_{AX}</i> | °F | 34.2 | 39.7 | 50.1 | 58.5 | 69.1 | 78 | 81.7 | 78.9 | 72.6 | 61.3 | 46.5 | 34.9 | 58.8 |
| Alamosa, CO | <i>V</i> | mi/hr | 5.1 | 6.5 | 8.1 | 10.1 | 9.6 | 8.7 | 6.7 | 6.3 | 6.5 | 6.5 | 5.8 | 4.9 | 7.2 |
| Alamosa, CO | <i>I</i> | Btu/ft ² /day | 898 | 1191 | 1619 | 1987 | 2266 | 2427 | 2269 | 1992 | 1786 | 1397 | 1023 | 798 | 1638 |
| Alamosa, CO | <i>P_A</i> | psia | | | | | | | | | | | | | 11.2 |
| Colorado Springs, CO | <i>T_{AN}</i> | °F | 18.8 | 20.9 | 27.1 | 34.1 | 43.8 | 52.2 | 57.8 | 56.4 | 47.9 | 36.8 | 26 | 19.4 | 36.8 |
| Colorado Springs, CO | <i>T_{AX}</i> | °F | 42.6 | 45 | 51.9 | 58.6 | 68.8 | 78.1 | 84.1 | 80.9 | 74.2 | 62.6 | 50.1 | 42.5 | 61.6 |
| Colorado Springs, CO | <i>V</i> | mi/hr | 8.7 | 9.4 | 10.3 | 11.6 | 10.7 | 10.1 | 8.9 | 8.5 | 8.9 | 9.4 | 8.7 | 8.9 | 9.6 |
| Colorado Springs, CO | <i>I</i> | Btu/ft ² /day | 843 | 1093 | 1467 | 1794 | 2012 | 2182 | 2108 | 1884 | 1667 | 1275 | 899 | 742 | 1497 |
| Colorado Springs, CO | <i>P_A</i> | psia | | | | | | | | | | | | | 11.78 |
| Denver, CO | <i>T_{AN}</i> | °F | 19.2 | 21.7 | 28.2 | 34.8 | 44.7 | 53.2 | 60.4 | 58.7 | 49.6 | 37.7 | 26.7 | 19.6 | 37.9 |
| Denver, CO | <i>T_{AX}</i> | °F | 42.9 | 45.7 | 53.7 | 60.1 | 70.6 | 80.9 | 88 | 85.2 | 77.3 | 64 | 51.1 | 43 | 63.5 |
| Denver, CO | <i>V</i> | mi/hr | 9.2 | 9.2 | 10.3 | 11 | 10.1 | 9.6 | 9.2 | 8.9 | 8.9 | 9.2 | 8.9 | 9.2 | 9.4 |
| Denver, CO | <i>I</i> | Btu/ft ² /day | 764 | 1052 | 1463 | 1779 | 2049 | 2275 | 2213 | 1941 | 1658 | 1216 | 817 | 664 | 1491 |
| Denver, CO | <i>P_A</i> | psia | | | | | | | | | | | | | 12.08 |
| Grand Junction, CO | <i>T_{AN}</i> | °F | 19.3 | 25.9 | 32.7 | 39.5 | 48.8 | 57.9 | 65.2 | 62.8 | 53.4 | 41.3 | 28.8 | 19.9 | 41.3 |
| Grand Junction, CO | <i>T_{AX}</i> | °F | 37.4 | 45.3 | 56.5 | 64.4 | 76.2 | 86.9 | 93.4 | 89.3 | 79.9 | 66 | 49.9 | 38 | 65.3 |
| Grand Junction, CO | <i>V</i> | mi/hr | 5.4 | 6.5 | 7.8 | 8.9 | 9.2 | 9.6 | 9.4 | 8.9 | 8.5 | 7.6 | 6 | 5.4 | 7.8 |
| Grand Junction, CO | <i>I</i> | Btu/ft ² /day | 739 | 1039 | 1522 | 1876 | 2211 | 2434 | 2339 | 2020 | 1721 | 1281 | 874 | 662 | 1560 |
| Grand Junction, CO | <i>P_A</i> | psia | | | | | | | | | | | | | 12.34 |
| Limon, CO | <i>T_{AN}</i> | °F | 12.4 | 15.2 | 22 | 29.2 | 39.4 | 49.3 | 54.8 | 53.9 | 43.7 | 31.6 | 19.9 | 12.7 | 32 |
| Limon, CO | <i>T_{AX}</i> | °F | 41.7 | 44.2 | 52.7 | 59.5 | 69.7 | 79.6 | 86.2 | 82.7 | 75.8 | 63.4 | 49.6 | 41.8 | 62.2 |
| Limon, CO | <i>V</i> | mi/hr | 8.7 | 9.4 | 10.7 | 11.9 | 11 | 10.1 | 9.2 | 8.7 | 8.9 | 9.4 | 8.9 | 8.9 | 9.6 |
| Limon, CO | <i>I</i> | Btu/ft ² /day | 797 | 1066 | 1466 | 1773 | 2074 | 2301 | 2267 | 2003 | 1712 | 1264 | 860 | 693 | 1523 |

| | | | | | | | | | | | | | | | |
|-------------------|----------|--------------------------|------|------|------|------|------|------|------|------|------|------|------|------|-------|
| Limon, CO | P_A | psia | | | | | | | | | | | | | 12.02 |
| Pueblo, CO | T_{AN} | °F | 15.3 | 18.5 | 26.5 | 34.8 | 45.2 | 53.6 | 59.6 | 58.3 | 48.3 | 35.1 | 23.4 | 15.9 | 36.2 |
| Pueblo, CO | T_{AX} | °F | 47.2 | 50.8 | 58.9 | 66.1 | 76.7 | 86.3 | 92.3 | 88.8 | 81.4 | 68.9 | 55.1 | 46.8 | 68.3 |
| Pueblo, CO | V | mi/hr | 6.7 | 7.4 | 8.5 | 9.8 | 8.9 | 8.7 | 8.1 | 7.4 | 7.4 | 7.4 | 6.5 | 6.5 | 7.8 |
| Pueblo, CO | I | Btu/ft ² /day | 862 | 1144 | 1557 | 1897 | 2197 | 2399 | 2356 | 2093 | 1783 | 1344 | 950 | 779 | 1613 |
| Pueblo, CO | P_A | psia | | | | | | | | | | | | | 12.4 |
| Bridgeport, CT | T_{AN} | °F | 24.4 | 25.9 | 32.1 | 41.8 | 51.1 | 61.4 | 67 | 66.6 | 59.2 | 47.4 | 38.9 | 29.5 | 45.4 |
| Bridgeport, CT | T_{AX} | °F | 37.2 | 39.1 | 46.3 | 57.1 | 66.8 | 76.4 | 81.4 | 80.4 | 73.7 | 62.7 | 52.4 | 42.1 | 59.6 |
| Bridgeport, CT | V | mi/hr | 9.8 | 10.1 | 10.3 | 9.6 | 8.9 | 7.8 | 7.6 | 7.8 | 8.7 | 9.2 | 9.4 | 9.8 | 9.2 |
| Bridgeport, CT | I | Btu/ft ² /day | 560 | 847 | 1156 | 1490 | 1750 | 1862 | 1904 | 1685 | 1320 | 948 | 621 | 501 | 1220 |
| Bridgeport, CT | P_A | psia | | | | | | | | | | | | | 14.69 |
| Hartford, CT | T_{AN} | °F | 19.4 | 21.4 | 28.8 | 39.2 | 48.3 | 58.4 | 63.3 | 61.9 | 53.9 | 42.2 | 34.1 | 24.6 | 41.3 |
| Hartford, CT | T_{AX} | °F | 34.4 | 37.5 | 46.7 | 60.2 | 70.4 | 79.1 | 83.6 | 82.2 | 74.4 | 62.3 | 50.8 | 39.5 | 60.1 |
| Hartford, CT | V | mi/hr | 8.5 | 8.9 | 9.4 | 8.9 | 8.1 | 6.9 | 6.5 | 6.3 | 6.7 | 7.4 | 7.6 | 8.3 | 7.8 |
| Hartford, CT | I | Btu/ft ² /day | 560 | 814 | 1133 | 1453 | 1700 | 1797 | 1833 | 1622 | 1289 | 905 | 582 | 482 | 1181 |
| Hartford, CT | P_A | psia | | | | | | | | | | | | | 14.61 |
| Wilmington, DE | T_{AN} | °F | 26.3 | 27.2 | 34.3 | 43.8 | 53 | 63.2 | 67.9 | 66.9 | 58.9 | 46.8 | 38.4 | 30.1 | 46.4 |
| Wilmington, DE | T_{AX} | °F | 40.5 | 42.7 | 51.6 | 63.1 | 72.1 | 80.9 | 85.1 | 83.9 | 76.8 | 65.5 | 55 | 44.7 | 63.5 |
| Wilmington, DE | V | mi/hr | 9.4 | 9.8 | 10.1 | 9.6 | 8.3 | 7.6 | 7.4 | 6.9 | 7.8 | 7.6 | 8.5 | 8.9 | 8.5 |
| Wilmington, DE | I | Btu/ft ² /day | 629 | 911 | 1185 | 1528 | 1786 | 1909 | 1916 | 1680 | 1366 | 1016 | 678 | 556 | 1264 |
| Wilmington, DE | P_A | psia | | | | | | | | | | | | | 14.65 |
| Daytona Beach, FL | T_{AN} | °F | 49 | 50.6 | 55 | 59.8 | 66.4 | 72.1 | 73.7 | 74 | 73.2 | 66.9 | 57.7 | 52.3 | 62.5 |
| Daytona Beach, FL | T_{AX} | °F | 68.4 | 69.9 | 74.2 | 78.8 | 84.5 | 87.7 | 89.5 | 88.8 | 86.3 | 81.5 | 75.1 | 70.2 | 79.6 |
| Daytona Beach, FL | V | mi/hr | 7.2 | 7.6 | 8.3 | 7.8 | 7.4 | 6.3 | 5.6 | 5.6 | 6.7 | 7.4 | 6.9 | 6.7 | 6.9 |
| Daytona Beach, FL | I | Btu/ft ² /day | 1018 | 1215 | 1579 | 1931 | 2049 | 1893 | 1911 | 1767 | 1518 | 1296 | 1063 | 916 | 1513 |
| Daytona Beach, FL | P_A | psia | | | | | | | | | | | | | 14.68 |
| Fort Myers, FL | T_{AN} | °F | 54.4 | 56.1 | 59.8 | 64 | 69.3 | 73.8 | 75 | 75.4 | 74.7 | 69.4 | 61.8 | 56.7 | 65.9 |
| Fort Myers, FL | T_{AX} | °F | 74.2 | 76.2 | 79.6 | 83.5 | 88.5 | 90.3 | 90.7 | 90.8 | 89.3 | 85.8 | 80.2 | 75.5 | 83.7 |

| | | | | | | | | | | | | | | | |
|------------------|----------|--------------------------|------|------|------|------|------|------|------|------|------|------|------|------|-------|
| Fort Myers, FL | V | mi/hr | 7.4 | 7.8 | 8.3 | 8.1 | 7.2 | 6.3 | 5.4 | 5.6 | 6.3 | 7.2 | 7.4 | 7.2 | 6.9 |
| Fort Myers, FL | I | Btu/ft ² /day | 1150 | 1426 | 1718 | 1993 | 2075 | 1880 | 1805 | 1740 | 1533 | 1415 | 1205 | 1054 | 1583 |
| Fort Myers, FL | P_A | psia | | | | | | | | | | | | | 14.68 |
| Gainesville, FL | T_{AN} | °F | 43.4 | 45.5 | 50.2 | 55.6 | 63.2 | 69.8 | 72.1 | 72.1 | 69.4 | 61.1 | 51.4 | 45.5 | 58.3 |
| Gainesville, FL | T_{AX} | °F | 66.3 | 69 | 74.4 | 80 | 86.4 | 89 | 90.2 | 89.4 | 86.6 | 80.7 | 73.6 | 67.6 | 79.4 |
| Gainesville, FL | V | mi/hr | 6.5 | 6.9 | 7.4 | 7.2 | 6.7 | 5.6 | 5.1 | 4.9 | 5.8 | 5.8 | 6 | 5.8 | 6.3 |
| Gainesville, FL | I | Btu/ft ² /day | 970 | 1213 | 1549 | 1890 | 2019 | 1865 | 1863 | 1704 | 1484 | 1276 | 1063 | 887 | 1482 |
| Gainesville, FL | P_A | psia | | | | | | | | | | | | | 14.62 |
| Jacksonville, FL | T_{AN} | °F | 42.9 | 45.1 | 50.1 | 55.5 | 63.7 | 70.5 | 72.9 | 73.1 | 70.1 | 61 | 50.8 | 44.4 | 58.3 |
| Jacksonville, FL | T_{AX} | °F | 64.5 | 67.2 | 72.7 | 78.3 | 84.8 | 88.7 | 91 | 89.6 | 85.8 | 79.6 | 72.2 | 65.4 | 78.3 |
| Jacksonville, FL | V | mi/hr | 7.2 | 7.4 | 8.1 | 7.6 | 7.2 | 6.5 | 5.8 | 5.8 | 6.5 | 6.3 | 6.3 | 6.5 | 6.7 |
| Jacksonville, FL | I | Btu/ft ² /day | 937 | 1186 | 1522 | 1890 | 2035 | 1911 | 1948 | 1756 | 1466 | 1237 | 1021 | 846 | 1480 |
| Jacksonville, FL | P_A | psia | | | | | | | | | | | | | 14.68 |
| Key West, FL | T_{AN} | °F | 64.9 | 66.2 | 68.7 | 72.2 | 76.2 | 79.4 | 80.6 | 80.5 | 79.2 | 76.5 | 71.8 | 67.1 | 73.6 |
| Key West, FL | T_{AX} | °F | 74.4 | 75.7 | 78.2 | 81 | 84.6 | 87.7 | 89 | 89.4 | 87.7 | 84.5 | 79.6 | 75.7 | 82.3 |
| Key West, FL | V | mi/hr | 11 | 10.5 | 11 | 11.2 | 9.8 | 8.7 | 8.5 | 8.3 | 8.7 | 10.1 | 11.2 | 10.5 | 10.1 |
| Key West, FL | I | Btu/ft ² /day | 1206 | 1462 | 1805 | 2069 | 2131 | 2035 | 2041 | 1943 | 1667 | 1465 | 1240 | 1098 | 1680 |
| Key West, FL | P_A | psia | | | | | | | | | | | | | 14.69 |
| Miami, FL | T_{AN} | °F | 61.2 | 62.6 | 65.8 | 69.4 | 73.9 | 76.6 | 78.1 | 78.2 | 77.3 | 74.3 | 68.4 | 63.6 | 70.8 |
| Miami, FL | T_{AX} | °F | 75.5 | 77 | 79.6 | 82.4 | 86.2 | 88.4 | 89.9 | 90 | 88.2 | 85.1 | 80.5 | 76.9 | 83.3 |
| Miami, FL | V | mi/hr | 8.5 | 8.5 | 9.6 | 9.8 | 8.7 | 7.4 | 7.2 | 6.9 | 7.4 | 8.3 | 8.5 | 8.1 | 8.3 |
| Miami, FL | I | Btu/ft ² /day | 1118 | 1346 | 1625 | 1875 | 1938 | 1737 | 1813 | 1701 | 1456 | 1309 | 1113 | 1015 | 1504 |
| Miami, FL | P_A | psia | | | | | | | | | | | | | 14.68 |
| Orlando, FL | T_{AN} | °F | 50.5 | 52.5 | 56.5 | 61 | 67.3 | 72.4 | 74 | 74.4 | 73.2 | 66.8 | 58.7 | 52.9 | 63.4 |
| Orlando, FL | T_{AX} | °F | 70.7 | 72.8 | 77.2 | 81.7 | 87.2 | 89.5 | 90.8 | 90.5 | 88.3 | 83.4 | 77 | 71.8 | 81.8 |
| Orlando, FL | V | mi/hr | 8.3 | 8.7 | 9.2 | 8.7 | 8.1 | 6.9 | 6.3 | 6.5 | 7.2 | 7.8 | 8.1 | 7.8 | 7.8 |
| Orlando, FL | I | Btu/ft ² /day | 1043 | 1257 | 1588 | 1904 | 2021 | 1849 | 1854 | 1726 | 1506 | 1328 | 1096 | 944 | 1510 |
| Orlando, FL | P_A | psia | | | | | | | | | | | | | 14.65 |
| Pensacola, FL | T_{AN} | °F | 43.5 | 46 | 52 | 58.6 | 67 | 73.3 | 75.2 | 74.8 | 71.1 | 61.1 | 51 | 44.6 | 59.9 |
| Pensacola, FL | T_{AX} | °F | 61 | 63.9 | 69.8 | 75.6 | 83.4 | 88.4 | 89.9 | 89.4 | 86.6 | 79 | 70.1 | 62.6 | 76.6 |

| | | | | | | | | | | | | | | | |
|---------------------|-----------------------|--------------------------|------|------|------|------|------|------|------|------|------|------|------|------|-------|
| Pensacola, FL | <i>V</i> | mi/hr | 8.7 | 8.7 | 9.2 | 9.2 | 8.3 | 7.2 | 6.5 | 6.3 | 7.2 | 7.4 | 7.8 | 8.1 | 7.8 |
| Pensacola, FL | <i>I</i> | Btu/ft ² /day | 890 | 1144 | 1504 | 1813 | 2038 | 2019 | 1911 | 1783 | 1594 | 1327 | 1040 | 830 | 1491 |
| Pensacola, FL | <i>P_A</i> | psia | | | | | | | | | | | | | 14.63 |
| Tallahassee, FL | <i>T_{AN}</i> | °F | 40.5 | 42.4 | 47.9 | 53.7 | 62.8 | 70.3 | 72.8 | 72.8 | 69.1 | 58.2 | 47.6 | 41.5 | 56.6 |
| Tallahassee, FL | <i>T_{AX}</i> | °F | 63.6 | 66.8 | 73.3 | 79.4 | 86.7 | 90.1 | 91.6 | 90.9 | 87.9 | 80.9 | 72 | 64.7 | 79 |
| Tallahassee, FL | <i>V</i> | mi/hr | 5.8 | 6.3 | 6.5 | 6.3 | 6 | 5.1 | 4.5 | 4.7 | 5.6 | 5.4 | 5.4 | 5.4 | 5.6 |
| Tallahassee, FL | <i>I</i> | Btu/ft ² /day | 933 | 1195 | 1553 | 1904 | 2031 | 1925 | 1866 | 1764 | 1565 | 1327 | 1070 | 872 | 1500 |
| Tallahassee, FL | <i>P_A</i> | psia | | | | | | | | | | | | | 14.65 |
| Tampa, FL | <i>T_{AN}</i> | °F | 52.3 | 54.1 | 58.5 | 63.5 | 70.2 | 74.8 | 76.2 | 76.2 | 74.6 | 68.2 | 59.9 | 54.3 | 65.2 |
| Tampa, FL | <i>T_{AX}</i> | °F | 69.8 | 71.6 | 75.9 | 80.8 | 86.7 | 89.1 | 89.5 | 89.6 | 88.4 | 83.8 | 77.1 | 71.4 | 81.2 |
| Tampa, FL | <i>V</i> | mi/hr | 7.2 | 7.4 | 8.1 | 7.8 | 7.2 | 6.5 | 5.6 | 5.6 | 6.3 | 6.7 | 6.9 | 6.7 | 6.7 |
| Tampa, FL | <i>I</i> | Btu/ft ² /day | 1073 | 1294 | 1656 | 1991 | 2124 | 1962 | 1851 | 1732 | 1561 | 1394 | 1158 | 990 | 1566 |
| Tampa, FL | <i>P_A</i> | psia | | | | | | | | | | | | | 14.68 |
| Vero Beach, FL | <i>T_{AN}</i> | °F | 52.7 | 54.2 | 58.2 | 62.3 | 68.5 | 72.6 | 73.9 | 73.9 | 73.9 | 69.6 | 62 | 56.4 | 64.9 |
| Vero Beach, FL | <i>T_{AX}</i> | °F | 72.3 | 73.9 | 77.1 | 80.2 | 84.6 | 87.9 | 89.4 | 89.3 | 87.5 | 83.7 | 78.3 | 74.1 | 81.5 |
| Vero Beach, FL | <i>V</i> | mi/hr | 8.5 | 8.7 | 9.6 | 9.6 | 8.9 | 7.6 | 6.7 | 6.7 | 7.4 | 8.5 | 8.5 | 8.1 | 8.3 |
| Vero Beach, FL | <i>I</i> | Btu/ft ² /day | 1052 | 1300 | 1593 | 1906 | 2000 | 1848 | 1898 | 1752 | 1516 | 1318 | 1083 | 949 | 1518 |
| Vero Beach, FL | <i>P_A</i> | psia | | | | | | | | | | | | | 14.68 |
| West Palm Beach, FL | <i>T_{AN}</i> | °F | 58.1 | 59.4 | 63.1 | 67.1 | 72 | 75.1 | 76.4 | 76.6 | 76 | 72.6 | 65.8 | 60.6 | 68.6 |
| West Palm Beach, FL | <i>T_{AX}</i> | °F | 74 | 75.6 | 78.4 | 81.2 | 85.3 | 87.8 | 89.2 | 89.3 | 87.6 | 84.4 | 79.4 | 75.5 | 82.3 |
| West Palm Beach, FL | <i>V</i> | mi/hr | 9.8 | 9.8 | 11 | 10.7 | 9.8 | 7.8 | 7.4 | 7.4 | 8.3 | 9.4 | 9.8 | 9.4 | 9.2 |
| West Palm Beach, FL | <i>I</i> | Btu/ft ² /day | 1105 | 1342 | 1635 | 1912 | 1999 | 1852 | 1936 | 1789 | 1555 | 1352 | 1113 | 998 | 1549 |
| West Palm Beach, FL | <i>P_A</i> | psia | | | | | | | | | | | | | 14.68 |
| Athens, GA | <i>T_{AN}</i> | °F | 34.4 | 36.8 | 43.1 | 50.1 | 58.9 | 66.7 | 70.2 | 69.6 | 63.3 | 52 | 42.4 | 35.5 | 51.9 |
| Athens, GA | <i>T_{AX}</i> | °F | 53.2 | 56.8 | 64.8 | 72.9 | 80.2 | 86.7 | 89.8 | 88.6 | 82.7 | 73.1 | 63.5 | 54.5 | 72.2 |
| Athens, GA | <i>V</i> | mi/hr | 7.4 | 7.4 | 7.6 | 6.9 | 6 | 5.4 | 5.1 | 4.9 | 5.6 | 5.6 | 6 | 6.7 | 6.3 |
| Athens, GA | <i>I</i> | Btu/ft ² /day | 819 | 1062 | 1390 | 1764 | 1951 | 1978 | 1946 | 1760 | 1487 | 1211 | 915 | 743 | 1419 |
| Athens, GA | <i>P_A</i> | psia | | | | | | | | | | | | | 14.27 |

| | | | | | | | | | | | | | | | |
|--------------|----------|--------------------------|------|------|------|------|------|------|------|------|------|------|------|------|-------|
| Atlanta, GA | T_{AN} | °F | 35.5 | 38.2 | 44.8 | 52.3 | 61.2 | 68.5 | 71.7 | 71.3 | 65.4 | 54.4 | 44.2 | 37.1 | 53.7 |
| Atlanta, GA | T_{AX} | °F | 52.8 | 56.5 | 64.1 | 72.2 | 79.5 | 85.5 | 88.4 | 87.6 | 81.9 | 72.4 | 62.7 | 53.9 | 71.5 |
| Atlanta, GA | V | mi/hr | 9.4 | 9.4 | 9.6 | 8.7 | 7.8 | 7.4 | 6.9 | 6.7 | 7.6 | 7.8 | 8.1 | 8.9 | 8.3 |
| Atlanta, GA | I | Btu/ft ² /day | 801 | 1046 | 1379 | 1747 | 1925 | 1949 | 1925 | 1739 | 1477 | 1201 | 896 | 718 | 1400 |
| Atlanta, GA | P_A | psia | | | | | | | | | | | | | 14.17 |
| Augusta, GA | T_{AN} | °F | 34.7 | 36.7 | 43 | 49.6 | 58.6 | 67.2 | 70.5 | 70 | 63.7 | 51.9 | 41.8 | 35.3 | 51.9 |
| Augusta, GA | T_{AX} | °F | 57.7 | 61.1 | 68.7 | 76.4 | 83.8 | 89.2 | 91.8 | 90.6 | 85.5 | 76.6 | 67.6 | 58.9 | 75.7 |
| Augusta, GA | V | mi/hr | 6 | 6.3 | 6.7 | 6.3 | 5.6 | 4.9 | 4.7 | 4 | 4.7 | 4.5 | 4.9 | 5.4 | 5.4 |
| Augusta, GA | I | Btu/ft ² /day | 836 | 1084 | 1432 | 1806 | 1995 | 1979 | 1965 | 1782 | 1509 | 1214 | 935 | 775 | 1443 |
| Augusta, GA | P_A | psia | | | | | | | | | | | | | 14.62 |
| Columbus, GA | T_{AN} | °F | 38 | 40.4 | 46.6 | 53.5 | 62.9 | 70.1 | 73.2 | 72.7 | 67.3 | 56.2 | 45.9 | 39.1 | 55.5 |
| Columbus, GA | T_{AX} | °F | 57.4 | 61.2 | 68.7 | 76 | 83.4 | 88.5 | 91.3 | 90.4 | 85.5 | 76.4 | 67.2 | 58.4 | 75.4 |
| Columbus, GA | V | mi/hr | 6.5 | 6.7 | 7.2 | 6.7 | 6.3 | 5.6 | 5.6 | 5.1 | 6 | 5.6 | 5.6 | 6 | 6 |
| Columbus, GA | I | Btu/ft ² /day | 823 | 1079 | 1409 | 1773 | 1936 | 1936 | 1936 | 1718 | 1491 | 1211 | 949 | 753 | 1418 |
| Columbus, GA | P_A | psia | | | | | | | | | | | | | 14.49 |
| Macon, GA | T_{AN} | °F | 36.3 | 38.6 | 44.8 | 51 | 60.1 | 68.3 | 71.6 | 70.8 | 64.7 | 53 | 43 | 36.8 | 53.2 |
| Macon, GA | T_{AX} | °F | 57.8 | 61.3 | 68.8 | 76.1 | 83.9 | 89 | 91.7 | 90.5 | 85.5 | 76.6 | 67.6 | 58.9 | 75.7 |
| Macon, GA | V | mi/hr | 6.7 | 6.7 | 6.9 | 6.5 | 6 | 5.4 | 4.9 | 4.7 | 5.4 | 5.1 | 5.4 | 6 | 5.8 |
| Macon, GA | I | Btu/ft ² /day | 852 | 1107 | 1460 | 1839 | 2026 | 1978 | 1981 | 1788 | 1523 | 1233 | 960 | 783 | 1461 |
| Macon, GA | P_A | psia | | | | | | | | | | | | | 14.5 |
| Savannah, GA | T_{AN} | °F | 40 | 42 | 48.3 | 54.5 | 62.9 | 70.4 | 73.3 | 73 | 68.6 | 58.1 | 47.9 | 41.3 | 56.7 |
| Savannah, GA | T_{AX} | °F | 60.5 | 63.5 | 70.2 | 76.9 | 83.6 | 88.3 | 91.3 | 89.7 | 85.2 | 77.6 | 69.5 | 61.8 | 76.5 |
| Savannah, GA | V | mi/hr | 7.2 | 7.4 | 7.8 | 7.4 | 6.7 | 6.3 | 5.6 | 5.6 | 6.5 | 6.3 | 6 | 6.5 | 6.5 |
| Savannah, GA | I | Btu/ft ² /day | 876 | 1134 | 1484 | 1847 | 2015 | 1947 | 1981 | 1765 | 1477 | 1224 | 993 | 817 | 1464 |
| Savannah, GA | P_A | psia | | | | | | | | | | | | | 14.66 |
| Hilo, HI | T_{AN} | °F | 64.1 | 64 | 65.1 | 65.9 | 67.2 | 68.5 | 69.5 | 70 | 69.4 | 68.8 | 67.5 | 65.6 | 67.1 |
| Hilo, HI | T_{AX} | °F | 78.6 | 78.1 | 78.5 | 78.7 | 80.7 | 81.9 | 82.7 | 83 | 83 | 82.3 | 80.4 | 79 | 80.6 |
| Hilo, HI | V | mi/hr | 6.7 | 7.2 | 7.2 | 6.9 | 6.7 | 6.5 | 6.5 | 6.3 | 6.3 | 6.3 | 6.3 | 6.5 | 6.5 |
| Hilo, HI | I | Btu/ft ² /day | 1187 | 1316 | 1431 | 1617 | 1743 | 1820 | 1822 | 1748 | 1672 | 1413 | 1137 | 1076 | 1498 |
| Hilo, HI | P_A | psia | | | | | | | | | | | | | 14.68 |

| | | | | | | | | | | | | | | | |
|---------------|----------|--------------------------|------|------|------|------|------|------|------|------|------|------|------|------|-------|
| Honolulu, HI | T_{AN} | °F | 67.1 | 67.3 | 68.5 | 70.3 | 71.8 | 74.3 | 75.3 | 76 | 75.1 | 74.2 | 72.1 | 69.5 | 71.8 |
| Honolulu, HI | T_{AX} | °F | 79.5 | 79.6 | 80.4 | 82.3 | 84.1 | 86.3 | 87.2 | 88 | 87.6 | 86 | 83.2 | 80.8 | 83.8 |
| Honolulu, HI | V | mi/hr | 8.7 | 9.2 | 10.3 | 11.2 | 10.3 | 12.1 | 12.1 | 12.1 | 10.5 | 10.1 | 9.6 | 9.4 | 10.5 |
| Honolulu, HI | I | Btu/ft ² /day | 1279 | 1511 | 1737 | 1995 | 2071 | 2155 | 2127 | 2075 | 1901 | 1595 | 1318 | 1177 | 1745 |
| Honolulu, HI | P_A | psia | | | | | | | | | | | | | 14.69 |
| Kahului, HI | T_{AN} | °F | 64 | 63.7 | 65 | 66.5 | 67.7 | 70.3 | 71.8 | 72.3 | 71.2 | 70.2 | 68.4 | 65.9 | 68.1 |
| Kahului, HI | T_{AX} | °F | 79.7 | 79.7 | 80.3 | 81.6 | 83.9 | 85.5 | 86.3 | 87 | 87 | 86 | 83.1 | 80.9 | 83.4 |
| Kahului, HI | V | mi/hr | 10.5 | 11.2 | 11.9 | 13 | 12.1 | 14.8 | 15 | 14.5 | 12.8 | 11.9 | 11.2 | 10.7 | 12.5 |
| Kahului, HI | I | Btu/ft ² /day | 1335 | 1552 | 1727 | 1984 | 2126 | 2228 | 2164 | 2115 | 1932 | 1682 | 1377 | 1257 | 1790 |
| Kahului, HI | P_A | psia | | | | | | | | | | | | | 14.66 |
| Lihue, HI | T_{AN} | °F | 66 | 66.3 | 67.4 | 69.3 | 71 | 73.7 | 74.6 | 75.2 | 74.7 | 73.7 | 71.3 | 68.7 | 71 |
| Lihue, HI | T_{AX} | °F | 77.1 | 76.6 | 77.3 | 78.2 | 80.5 | 82.4 | 83.4 | 83.9 | 84 | 82.7 | 80 | 78.2 | 80.4 |
| Lihue, HI | V | mi/hr | 11.9 | 12.5 | 13.2 | 14.3 | 12.8 | 14.3 | 14.8 | 14.3 | 13 | 13 | 13.2 | 12.8 | 13.4 |
| Lihue, HI | I | Btu/ft ² /day | 1193 | 1375 | 1566 | 1755 | 1941 | 2022 | 1956 | 1918 | 1779 | 1427 | 1161 | 1036 | 1594 |
| Lihue, HI | P_A | psia | | | | | | | | | | | | | 14.63 |
| Boise, ID | T_{AN} | °F | 26.2 | 29 | 34.5 | 39.3 | 47.2 | 53.9 | 61.5 | 60.5 | 52.2 | 41.3 | 31.9 | 26.2 | 42 |
| Boise, ID | T_{AX} | °F | 38.5 | 45.3 | 54.4 | 61 | 71.3 | 80 | 91.3 | 89.3 | 79.1 | 64 | 47.8 | 38.5 | 63.4 |
| Boise, ID | V | mi/hr | 6.9 | 7.6 | 8.7 | 8.7 | 8.3 | 8.1 | 7.6 | 7.4 | 7.2 | 7.2 | 6.9 | 7.4 | 7.6 |
| Boise, ID | I | Btu/ft ² /day | 492 | 831 | 1255 | 1705 | 2135 | 2360 | 2476 | 2163 | 1695 | 1102 | 580 | 427 | 1435 |
| Boise, ID | P_A | psia | | | | | | | | | | | | | 13.52 |
| Lewiston, ID | T_{AN} | °F | 30.7 | 32.4 | 36.4 | 41.2 | 48.1 | 54.1 | 61.3 | 60.3 | 52.4 | 42 | 34.7 | 29.9 | 43.6 |
| Lewiston, ID | T_{AX} | °F | 41.1 | 46.7 | 54.1 | 60.9 | 70.1 | 77.1 | 88.9 | 88.1 | 78.2 | 61.6 | 47.4 | 39.7 | 62.8 |
| Lewiston, ID | V | mi/hr | 6 | 5.6 | 6 | 6 | 5.6 | 5.6 | 5.6 | 5.4 | 4.7 | 4.7 | 5.4 | 6 | 5.6 |
| Lewiston, ID | I | Btu/ft ² /day | 407 | 698 | 1068 | 1497 | 1870 | 2063 | 2307 | 2003 | 1473 | 882 | 448 | 326 | 1254 |
| Lewiston, ID | P_A | psia | | | | | | | | | | | | | 13.95 |
| Pocatello, ID | T_{AN} | °F | 18 | 20.7 | 27.9 | 33.5 | 40.8 | 47 | 53.2 | 51.5 | 42.9 | 33.8 | 24.4 | 18.7 | 34.4 |
| Pocatello, ID | T_{AX} | °F | 33.4 | 38.1 | 49 | 57.4 | 67.9 | 76.7 | 87.9 | 86.8 | 76 | 60.7 | 44.5 | 33.8 | 59.3 |
| Pocatello, ID | V | mi/hr | 9.4 | 8.9 | 10.5 | 11.2 | 10.3 | 9.6 | 8.5 | 8.5 | 8.3 | 9.4 | 9.4 | 9.4 | 9.4 |
| Pocatello, ID | I | Btu/ft ² /day | 485 | 817 | 1292 | 1680 | 2084 | 2327 | 2398 | 2081 | 1634 | 1103 | 605 | 413 | 1410 |
| Pocatello, ID | P_A | psia | | | | | | | | | | | | | 12.52 |

| | | | | | | | | | | | | | | | |
|-----------------|----------|--------------------------|------|------|------|------|------|------|------|------|------|------|------|------|-------|
| Chicago, IL | T_{AN} | °F | 17.7 | 21.4 | 29.8 | 39.8 | 49.3 | 59.3 | 64.9 | 64 | 55.3 | 44.2 | 33.3 | 22.3 | 41.8 |
| Chicago, IL | T_{AX} | °F | 30.7 | 35.2 | 46 | 58.4 | 69.1 | 78.9 | 83 | 81 | 74.2 | 61.8 | 47.7 | 34.9 | 58.4 |
| Chicago, IL | V | mi/hr | 11 | 10.7 | 11 | 11.2 | 9.8 | 8.5 | 8.3 | 7.8 | 8.3 | 9.6 | 10.5 | 10.3 | 9.8 |
| Chicago, IL | I | Btu/ft ² /day | 487 | 755 | 1103 | 1453 | 1718 | 1939 | 1898 | 1621 | 1332 | 913 | 549 | 423 | 1183 |
| Chicago, IL | P_A | psia | | | | | | | | | | | | | 14.34 |
| Moline, IL | T_{AN} | °F | 15.3 | 20.2 | 29.9 | 40.9 | 51.2 | 61 | 65.1 | 63.5 | 54.2 | 43.2 | 31.9 | 20.3 | 41.4 |
| Moline, IL | T_{AX} | °F | 30.5 | 35.8 | 48.7 | 62.1 | 72.3 | 81.6 | 84.5 | 82.8 | 76.2 | 63.8 | 48.7 | 34.9 | 60.2 |
| Moline, IL | V | mi/hr | 9.2 | 8.9 | 9.8 | 10.1 | 8.5 | 6.9 | 6.3 | 5.8 | 6.5 | 7.8 | 8.7 | 8.5 | 8.1 |
| Moline, IL | I | Btu/ft ² /day | 532 | 798 | 1181 | 1469 | 1756 | 1959 | 1949 | 1712 | 1400 | 946 | 593 | 456 | 1229 |
| Moline, IL | P_A | psia | | | | | | | | | | | | | 14.39 |
| Peoria, IL | T_{AN} | °F | 17.8 | 22.2 | 31.4 | 42.4 | 52.4 | 62 | 65.8 | 64.6 | 55.7 | 44.3 | 33.3 | 22.5 | 42.9 |
| Peoria, IL | T_{AX} | °F | 32.1 | 37.8 | 50 | 62.6 | 72.3 | 81.4 | 84.5 | 83 | 76.5 | 64.1 | 49.7 | 36.4 | 60.9 |
| Peoria, IL | V | mi/hr | 9.2 | 9.2 | 9.8 | 10.1 | 8.5 | 7.2 | 6.5 | 6 | 6.5 | 7.8 | 8.9 | 8.7 | 8.3 |
| Peoria, IL | I | Btu/ft ² /day | 553 | 845 | 1179 | 1503 | 1746 | 1990 | 1982 | 1724 | 1444 | 983 | 608 | 475 | 1253 |
| Peoria, IL | P_A | psia | | | | | | | | | | | | | 14.34 |
| Rockford, IL | T_{AN} | °F | 14.1 | 18.5 | 27.7 | 38.6 | 48.9 | 59.1 | 62.8 | 61.6 | 52.6 | 41.4 | 30.6 | 18.9 | 39.6 |
| Rockford, IL | T_{AX} | °F | 28.3 | 33.4 | 45.7 | 59.4 | 70.1 | 79.5 | 82.5 | 81 | 74.2 | 61.7 | 46.5 | 32.8 | 57.9 |
| Rockford, IL | V | mi/hr | 9.8 | 9.8 | 10.5 | 11.2 | 9.6 | 7.8 | 7.2 | 6.7 | 7.4 | 8.9 | 9.8 | 9.4 | 8.9 |
| Rockford, IL | I | Btu/ft ² /day | 483 | 766 | 1123 | 1442 | 1700 | 1933 | 1881 | 1647 | 1337 | 902 | 545 | 401 | 1180 |
| Rockford, IL | P_A | psia | | | | | | | | | | | | | 14.32 |
| Springfield, IL | T_{AN} | °F | 19.9 | 24.2 | 32.9 | 43.4 | 53.8 | 62.7 | 65.6 | 64.5 | 55 | 44.6 | 34.6 | 24.4 | 43.8 |
| Springfield, IL | T_{AX} | °F | 34.3 | 40.2 | 51.7 | 64.3 | 73.9 | 82.1 | 85 | 84.1 | 78.2 | 66.1 | 51.7 | 38.7 | 62.5 |
| Springfield, IL | V | mi/hr | 10.7 | 10.7 | 11.2 | 11.4 | 9.4 | 7.6 | 6.5 | 6.3 | 6.7 | 8.7 | 10.5 | 10.3 | 9.2 |
| Springfield, IL | I | Btu/ft ² /day | 561 | 862 | 1179 | 1513 | 1747 | 1983 | 2017 | 1766 | 1459 | 1035 | 641 | 501 | 1272 |
| Springfield, IL | P_A | psia | | | | | | | | | | | | | 14.39 |
| Evansville, IN | T_{AN} | °F | 25.9 | 28.6 | 36.3 | 46.3 | 56.2 | 65.2 | 68.6 | 66.8 | 58.1 | 47.1 | 37.4 | 28.8 | 47.1 |
| Evansville, IN | T_{AX} | °F | 40.7 | 45.6 | 55.6 | 67.2 | 76 | 84.4 | 87.2 | 87.3 | 80.6 | 69.2 | 55.5 | 43.8 | 66.1 |
| Evansville, IN | V | mi/hr | 8.3 | 8.3 | 8.3 | 8.5 | 6.9 | 6 | 5.6 | 5.1 | 5.4 | 6 | 7.4 | 7.6 | 6.9 |
| Evansville, IN | I | Btu/ft ² /day | 598 | 880 | 1173 | 1574 | 1796 | 2005 | 1994 | 1850 | 1484 | 1097 | 693 | 525 | 1306 |
| Evansville, IN | P_A | psia | | | | | | | | | | | | | 14.49 |

| | | | | | | | | | | | | | | | |
|------------------|----------|--------------------------|------|------|------|------|------|------|------|------|------|------|------|------|-------|
| Fort Wayne, IN | T_{AN} | °F | 18.6 | 21.5 | 29.6 | 40 | 50 | 60.4 | 63.2 | 61.6 | 53.1 | 42.9 | 33.5 | 23.5 | 41.5 |
| Fort Wayne, IN | T_{AX} | °F | 32 | 36.2 | 47.4 | 60.7 | 70.9 | 80.1 | 83.2 | 81.3 | 75.5 | 63.1 | 49 | 36.1 | 59.6 |
| Fort Wayne, IN | V | mi/hr | 11 | 10.5 | 10.5 | 10.7 | 9.4 | 7.6 | 6.9 | 6.3 | 6.9 | 8.5 | 9.8 | 10.3 | 9.2 |
| Fort Wayne, IN | I | Btu/ft ² /day | 490 | 750 | 1131 | 1458 | 1709 | 1923 | 1944 | 1677 | 1371 | 935 | 560 | 420 | 1197 |
| Fort Wayne, IN | P_A | psia | | | | | | | | | | | | | 14.29 |
| Indianapolis, IN | T_{AN} | °F | 21.5 | 24.7 | 33.3 | 43.8 | 53.5 | 63.1 | 66.2 | 65.5 | 57.2 | 45.7 | 35.7 | 25.9 | 44.7 |
| Indianapolis, IN | T_{AX} | °F | 35.6 | 40.2 | 51.2 | 63.3 | 72.3 | 81.1 | 84.1 | 83.6 | 77.3 | 65.1 | 51.6 | 39.3 | 62 |
| Indianapolis, IN | V | mi/hr | 11 | 11 | 11 | 11.4 | 9.6 | 8.3 | 7.8 | 7.4 | 7.8 | 8.9 | 10.3 | 10.5 | 9.6 |
| Indianapolis, IN | I | Btu/ft ² /day | 550 | 815 | 1165 | 1486 | 1757 | 1958 | 1934 | 1739 | 1441 | 1012 | 615 | 472 | 1245 |
| Indianapolis, IN | P_A | psia | | | | | | | | | | | | | 14.29 |
| South Bend, IN | T_{AN} | °F | 18.6 | 21.4 | 28.9 | 39.2 | 49.2 | 59.4 | 63.3 | 62.2 | 54 | 43.4 | 33.5 | 23.6 | 41.4 |
| South Bend, IN | T_{AX} | °F | 31.3 | 35.4 | 46.5 | 59.5 | 69.6 | 79.1 | 82.3 | 80.5 | 73.9 | 61.7 | 47.8 | 35.5 | 58.6 |
| South Bend, IN | V | mi/hr | 10.7 | 10.3 | 10.3 | 10.5 | 9.2 | 7.6 | 7.4 | 6.7 | 7.2 | 8.5 | 9.6 | 10.1 | 8.9 |
| South Bend, IN | I | Btu/ft ² /day | 433 | 698 | 1130 | 1471 | 1729 | 1935 | 1898 | 1646 | 1335 | 889 | 518 | 389 | 1173 |
| South Bend, IN | P_A | psia | | | | | | | | | | | | | 14.29 |
| Des Moines, IA | T_{AN} | °F | 14.1 | 19.3 | 29.6 | 41.3 | 52.4 | 62.4 | 66.6 | 64.9 | 55.1 | 43.6 | 30.9 | 19.3 | 41.6 |
| Des Moines, IA | T_{AX} | °F | 29.6 | 35.5 | 48 | 61.3 | 71.2 | 80.5 | 84.3 | 82.7 | 75.5 | 62.9 | 47.4 | 34.5 | 59.5 |
| Des Moines, IA | V | mi/hr | 10.3 | 10.1 | 11 | 11.2 | 10.1 | 8.7 | 8.1 | 7.6 | 8.5 | 9.6 | 10.3 | 9.8 | 9.6 |
| Des Moines, IA | I | Btu/ft ² /day | 545 | 817 | 1181 | 1507 | 1782 | 1979 | 1995 | 1762 | 1435 | 986 | 613 | 482 | 1257 |
| Des Moines, IA | P_A | psia | | | | | | | | | | | | | 14.2 |
| Dubuque, IA | T_{AN} | °F | 11.8 | 16.7 | 27 | 38.4 | 49 | 58.9 | 62.3 | 60.9 | 52.1 | 40.7 | 29.2 | 17 | 38.7 |
| Dubuque, IA | T_{AX} | °F | 26 | 31.1 | 43.6 | 57.6 | 68.4 | 77.6 | 80.4 | 78.9 | 71.9 | 59.5 | 44.3 | 30.6 | 55.8 |
| Dubuque, IA | V | mi/hr | 11 | 11 | 11.4 | 11.9 | 10.1 | 8.5 | 7.6 | 7.2 | 8.3 | 10.1 | 11 | 10.5 | 9.8 |
| Dubuque, IA | I | Btu/ft ² /day | 503 | 764 | 1135 | 1476 | 1718 | 1933 | 1904 | 1668 | 1348 | 903 | 551 | 422 | 1194 |
| Dubuque, IA | P_A | psia | | | | | | | | | | | | | 14.14 |
| Mason City, IA | T_{AN} | °F | 7.8 | 12.9 | 24.1 | 35.7 | 47.4 | 57.7 | 61 | 58.6 | 48.9 | 37.7 | 25.5 | 13.5 | 35.9 |
| Mason City, IA | T_{AX} | °F | 23.6 | 29 | 41.6 | 57.7 | 68.9 | 78.5 | 81.6 | 79.4 | 72.9 | 59.8 | 42.9 | 28.7 | 55.4 |
| Mason City, IA | V | mi/hr | 12.3 | 12.3 | 12.5 | 13.2 | 12.3 | 10.3 | 8.7 | 7.8 | 9.2 | 11 | 11.9 | 11.9 | 11.2 |
| Mason City, IA | I | Btu/ft ² /day | 469 | 722 | 1111 | 1479 | 1707 | 1902 | 1944 | 1678 | 1308 | 878 | 538 | 388 | 1177 |
| Mason City, IA | P_A | psia | | | | | | | | | | | | | 14.07 |

| | | | | | | | | | | | | | | | |
|----------------|----------|--------------------------|------|------|------|------|------|------|------|------|------|------|------|------|-------|
| Sioux City, IA | T_{AN} | °F | 11 | 16.5 | 26.3 | 37.9 | 49.7 | 59.7 | 63.9 | 61.6 | 51.2 | 39.2 | 26.2 | 15.3 | 38.2 |
| Sioux City, IA | T_{AX} | °F | 28.9 | 34.7 | 46.7 | 61.1 | 72.2 | 81.2 | 84.4 | 82.6 | 76 | 63 | 46.2 | 32.7 | 59.1 |
| Sioux City, IA | V | mi/hr | 11 | 11 | 11.4 | 12.5 | 11.6 | 9.6 | 8.3 | 7.8 | 9.2 | 10.1 | 10.7 | 10.7 | 10.3 |
| Sioux City, IA | I | Btu/ft ² /day | 522 | 787 | 1178 | 1532 | 1774 | 2010 | 2046 | 1787 | 1418 | 982 | 624 | 468 | 1260 |
| Sioux City, IA | P_A | psia | | | | | | | | | | | | | 14.13 |
| Waterloo, IA | T_{AN} | °F | 9.7 | 15.3 | 26.2 | 37.7 | 49.4 | 59.7 | 62.8 | 60.4 | 51 | 39.6 | 27.4 | 15.3 | 37.9 |
| Waterloo, IA | T_{AX} | °F | 26.3 | 31.5 | 44.6 | 59.6 | 70.6 | 80 | 82.7 | 80.8 | 74.7 | 61.5 | 45.3 | 31.2 | 57.4 |
| Waterloo, IA | V | mi/hr | 10.5 | 10.7 | 11.2 | 11.9 | 10.5 | 8.7 | 7.6 | 7.2 | 8.1 | 9.6 | 10.3 | 10.1 | 9.6 |
| Waterloo, IA | I | Btu/ft ² /day | 505 | 755 | 1131 | 1451 | 1722 | 1924 | 1952 | 1698 | 1357 | 909 | 554 | 418 | 1198 |
| Waterloo, IA | P_A | psia | | | | | | | | | | | | | 14.24 |
| Concordia, KS | T_{AN} | °F | 19.3 | 23.3 | 31.9 | 42 | 52.8 | 62.7 | 68 | 66.1 | 56.5 | 44.6 | 32 | 22.1 | 43.4 |
| Concordia, KS | T_{AX} | °F | 37.6 | 43.2 | 53.9 | 64 | 73.7 | 84.3 | 89.7 | 87.9 | 79.3 | 66.8 | 51.6 | 40 | 64.3 |
| Concordia, KS | V | mi/hr | 10.3 | 10.7 | 12.1 | 12.8 | 11.2 | 10.7 | 10.1 | 9.4 | 10.5 | 10.7 | 11 | 10.3 | 10.7 |
| Concordia, KS | I | Btu/ft ² /day | 701 | 948 | 1319 | 1647 | 1881 | 2123 | 2140 | 1916 | 1544 | 1128 | 772 | 608 | 1394 |
| Concordia, KS | P_A | psia | | | | | | | | | | | | | 13.94 |
| Dodge City, KS | T_{AN} | °F | 20.8 | 24.4 | 31.6 | 40.9 | 52.1 | 61.4 | 66.7 | 65.4 | 56.1 | 43.7 | 30.7 | 22.6 | 43 |
| Dodge City, KS | T_{AX} | °F | 43.6 | 48.3 | 57.2 | 66.7 | 76.6 | 86 | 91.9 | 89.7 | 81.5 | 69.2 | 55.1 | 44.6 | 67.6 |
| Dodge City, KS | V | mi/hr | 12.1 | 12.8 | 14.1 | 14.8 | 13.6 | 13.2 | 12.1 | 11.4 | 12.8 | 12.8 | 12.5 | 12.1 | 13 |
| Dodge City, KS | I | Btu/ft ² /day | 816 | 1068 | 1439 | 1786 | 2049 | 2230 | 2272 | 1980 | 1636 | 1239 | 889 | 740 | 1512 |
| Dodge City, KS | P_A | psia | | | | | | | | | | | | | 13.39 |
| Goodland, KS | T_{AN} | °F | 17.7 | 20.4 | 27.1 | 35.3 | 46.3 | 56.3 | 62 | 60.5 | 50.6 | 38.1 | 26.5 | 18.8 | 38.3 |
| Goodland, KS | T_{AX} | °F | 41.8 | 45.4 | 54.4 | 62.7 | 72.9 | 83.2 | 89.2 | 86.3 | 78.5 | 65.6 | 51.7 | 42.9 | 64.5 |
| Goodland, KS | V | mi/hr | 11.6 | 12.1 | 13.2 | 13.9 | 13 | 12.3 | 11 | 10.5 | 11.4 | 11.9 | 11.6 | 11.6 | 12.1 |
| Goodland, KS | I | Btu/ft ² /day | 785 | 1014 | 1426 | 1762 | 2007 | 2274 | 2301 | 2013 | 1646 | 1216 | 826 | 681 | 1496 |
| Goodland, KS | P_A | psia | | | | | | | | | | | | | 12.88 |
| Russell, KS | T_{AN} | °F | 18.8 | 22.8 | 31.4 | 40.9 | 52.3 | 62.4 | 67.6 | 66.3 | 56.5 | 43.7 | 30.5 | 21.3 | 42.9 |
| Russell, KS | T_{AX} | °F | 40.7 | 45.6 | 55.6 | 65.2 | 75.1 | 85.6 | 91.6 | 89.1 | 80.7 | 68.3 | 53.9 | 42.3 | 66.1 |
| Russell, KS | V | mi/hr | 11.4 | 12.1 | 13.4 | 14.3 | 12.8 | 12.5 | 11.9 | 11.2 | 12.3 | 12.8 | 12.3 | 11.6 | 12.3 |
| Russell, KS | I | Btu/ft ² /day | 739 | 986 | 1343 | 1669 | 1944 | 2144 | 2176 | 1927 | 1571 | 1153 | 818 | 655 | 1427 |
| Russell, KS | P_A | psia | | | | | | | | | | | | | 13.74 |

| | | | | | | | | | | | | | | | |
|----------------|----------|--------------------------|------|------|------|------|------|------|------|------|------|------|------|------|-------|
| Topeka, KS | T_{AN} | °F | 20.3 | 25.1 | 33.7 | 44.3 | 55 | 64.6 | 69.3 | 67.4 | 57 | 45.8 | 33.8 | 24 | 45 |
| Topeka, KS | T_{AX} | °F | 39 | 45.3 | 55.7 | 65.9 | 75.4 | 83.9 | 89 | 88.5 | 79.6 | 68.1 | 53.9 | 42.3 | 65.6 |
| Topeka, KS | V | mi/hr | 8.1 | 8.3 | 9.6 | 9.8 | 8.3 | 7.6 | 6.7 | 6 | 6.7 | 7.4 | 8.1 | 7.6 | 7.8 |
| Topeka, KS | I | Btu/ft ² /day | 679 | 944 | 1277 | 1574 | 1809 | 2027 | 2069 | 1864 | 1497 | 1102 | 733 | 598 | 1348 |
| Topeka, KS | P_A | psia | | | | | | | | | | | | | 14.23 |
| Wichita, KS | T_{AN} | °F | 23.1 | 27.4 | 35.7 | 45.2 | 56.2 | 65.5 | 70.3 | 69.3 | 60 | 47.7 | 35.5 | 25.8 | 46.8 |
| Wichita, KS | T_{AX} | °F | 42.2 | 48.5 | 57.3 | 67 | 76.3 | 85.8 | 91.3 | 90.4 | 81.7 | 69.6 | 55.7 | 44 | 67.5 |
| Wichita, KS | V | mi/hr | 11 | 11.4 | 12.8 | 13.4 | 11.6 | 11.6 | 10.7 | 10.1 | 10.7 | 11.2 | 11.4 | 10.7 | 11.4 |
| Wichita, KS | I | Btu/ft ² /day | 763 | 1050 | 1345 | 1701 | 1930 | 2132 | 2179 | 1961 | 1567 | 1173 | 831 | 666 | 1442 |
| Wichita, KS | P_A | psia | | | | | | | | | | | | | 14.01 |
| Cincinnati, KY | T_{AN} | °F | 23.8 | 26.2 | 34.1 | 44.3 | 53.7 | 62.5 | 66.1 | 65.4 | 57.4 | 45.9 | 36.2 | 27.4 | 45.2 |
| Cincinnati, KY | T_{AX} | °F | 38.3 | 42.3 | 52.2 | 64.2 | 72.9 | 81.2 | 84.4 | 84.2 | 77.5 | 65.6 | 52.9 | 41.4 | 63.1 |
| Cincinnati, KY | V | mi/hr | 9.4 | 9.6 | 9.8 | 9.6 | 7.8 | 6.9 | 6.5 | 6.3 | 6.7 | 7.4 | 8.7 | 8.9 | 8.1 |
| Cincinnati, KY | I | Btu/ft ² /day | 553 | 832 | 1167 | 1532 | 1782 | 1956 | 1937 | 1768 | 1439 | 1027 | 644 | 487 | 1260 |
| Cincinnati, KY | P_A | psia | | | | | | | | | | | | | 14.24 |
| Jackson, KY | T_{AN} | °F | 27.9 | 30.5 | 37.8 | 47.7 | 55.4 | 63.1 | 66.6 | 65.7 | 58.9 | 48.7 | 39.6 | 31.4 | 47.8 |
| Jackson, KY | T_{AX} | °F | 43.1 | 46.9 | 56.2 | 67.4 | 73.7 | 80.4 | 83.2 | 83.4 | 77.3 | 67.4 | 55.9 | 46.2 | 65.1 |
| Jackson, KY | V | mi/hr | 6 | 6 | 6.3 | 6.3 | 4.5 | 3.6 | 3.4 | 3.1 | 3.8 | 4.3 | 5.4 | 5.6 | 4.9 |
| Jackson, KY | I | Btu/ft ² /day | 591 | 831 | 1165 | 1534 | 1745 | 1909 | 1882 | 1752 | 1416 | 1060 | 708 | 539 | 1261 |
| Jackson, KY | P_A | psia | | | | | | | | | | | | | 13.98 |
| Lexington, KY | T_{AN} | °F | 25.9 | 28.5 | 35.9 | 45.6 | 55 | 63.4 | 66.9 | 65.8 | 58.3 | 47.1 | 37.4 | 28.9 | 46.5 |
| Lexington, KY | T_{AX} | °F | 40.8 | 44.8 | 54.2 | 65.4 | 73.6 | 81.8 | 84.9 | 84.9 | 78.3 | 66.9 | 54.4 | 43.5 | 64.5 |
| Lexington, KY | V | mi/hr | 9.4 | 9.2 | 9.2 | 9.2 | 7.6 | 6.5 | 6 | 5.8 | 6.3 | 7.2 | 8.3 | 8.7 | 7.8 |
| Lexington, KY | I | Btu/ft ² /day | 571 | 841 | 1177 | 1572 | 1814 | 1963 | 1925 | 1782 | 1444 | 1079 | 688 | 517 | 1281 |
| Lexington, KY | P_A | psia | | | | | | | | | | | | | 14.18 |
| Louisville, KY | T_{AN} | °F | 27.7 | 30.5 | 38.2 | 48.2 | 57.8 | 66.8 | 70.3 | 69.4 | 61.2 | 49.7 | 39.7 | 30.9 | 49.2 |
| Louisville, KY | T_{AX} | °F | 42.3 | 46.8 | 56.6 | 67.9 | 76 | 84.1 | 87.3 | 87.4 | 80.6 | 69.2 | 56.6 | 44.9 | 66.7 |
| Louisville, KY | V | mi/hr | 8.9 | 8.9 | 8.9 | 8.9 | 7.6 | 6.9 | 6.7 | 6.3 | 6.3 | 6.7 | 7.8 | 8.1 | 7.6 |
| Louisville, KY | I | Btu/ft ² /day | 595 | 895 | 1206 | 1563 | 1816 | 1982 | 1963 | 1811 | 1471 | 1073 | 692 | 520 | 1299 |
| Louisville, KY | P_A | psia | | | | | | | | | | | | | 14.45 |

| | | | | | | | | | | | | | | | |
|------------------|----------|--------------------------|------|------|------|------|------|------|------|------|------|------|------|------|-------|
| Paducah, KY | T_{AN} | °F | 27.4 | 30.6 | 38.3 | 47.8 | 57.2 | 65.7 | 69.1 | 66.8 | 58.2 | 47.5 | 38.2 | 30 | 48.1 |
| Paducah, KY | T_{AX} | °F | 43.4 | 48.5 | 58.3 | 69 | 77.5 | 85.4 | 88.3 | 88.2 | 81.5 | 70.6 | 57.3 | 46 | 67.8 |
| Paducah, KY | V | mi/hr | 8.3 | 8.3 | 8.9 | 8.5 | 6.9 | 5.8 | 5.4 | 4.7 | 5.1 | 6 | 7.4 | 7.8 | 6.9 |
| Paducah, KY | I | Btu/ft ² /day | 630 | 893 | 1224 | 1607 | 1820 | 2017 | 2031 | 1888 | 1494 | 1121 | 726 | 556 | 1334 |
| Paducah, KY | P_A | psia | | | | | | | | | | | | | 14.47 |
| Baton Rouge, LA | T_{AN} | °F | 42.2 | 44.5 | 50.5 | 56.9 | 65.5 | 71.4 | 73.9 | 73.2 | 68.6 | 58.1 | 48.2 | 42.8 | 58 |
| Baton Rouge, LA | T_{AX} | °F | 61.6 | 65.2 | 71.4 | 78 | 85 | 89.4 | 90.9 | 91.3 | 87.6 | 79.7 | 70.1 | 63.1 | 77.8 |
| Baton Rouge, LA | V | mi/hr | 7.2 | 7.4 | 7.4 | 7.4 | 6.5 | 5.4 | 4.9 | 4.5 | 5.1 | 5.4 | 5.8 | 6.5 | 6 |
| Baton Rouge, LA | I | Btu/ft ² /day | 822 | 1075 | 1375 | 1736 | 1894 | 1914 | 1896 | 1813 | 1553 | 1291 | 983 | 784 | 1428 |
| Baton Rouge, LA | P_A | psia | | | | | | | | | | | | | 14.66 |
| Lake Charles, LA | T_{AN} | °F | 43.4 | 46.1 | 52.1 | 59 | 67.5 | 73.4 | 75.4 | 74.6 | 69.9 | 60.3 | 50.5 | 44.6 | 59.7 |
| Lake Charles, LA | T_{AX} | °F | 61.4 | 64.7 | 70.8 | 77.2 | 84.2 | 89 | 90.6 | 91.2 | 87.8 | 80.3 | 70.5 | 63.3 | 77.6 |
| Lake Charles, LA | V | mi/hr | 8.7 | 8.9 | 8.9 | 8.7 | 7.4 | 6.3 | 5.4 | 5.1 | 6.5 | 7.2 | 7.6 | 8.5 | 7.4 |
| Lake Charles, LA | I | Btu/ft ² /day | 833 | 1046 | 1395 | 1727 | 1920 | 1977 | 1930 | 1825 | 1575 | 1321 | 987 | 786 | 1443 |
| Lake Charles, LA | P_A | psia | | | | | | | | | | | | | 14.68 |
| New Orleans, LA | T_{AN} | °F | 45.7 | 48.1 | 53.8 | 60.5 | 68.6 | 73.9 | 75.7 | 75.6 | 72.7 | 63.4 | 52.9 | 46.9 | 61.5 |
| New Orleans, LA | T_{AX} | °F | 61.8 | 65.1 | 70.9 | 77.5 | 84.7 | 88.9 | 90.6 | 90.4 | 87 | 79.5 | 70.5 | 63.6 | 77.5 |
| New Orleans, LA | V | mi/hr | 9.2 | 9.2 | 9.4 | 9.4 | 8.1 | 6.5 | 5.8 | 5.8 | 7.4 | 8.1 | 8.1 | 8.7 | 8.1 |
| New Orleans, LA | I | Btu/ft ² /day | 873 | 1114 | 1454 | 1798 | 1964 | 1928 | 1856 | 1791 | 1570 | 1328 | 1038 | 827 | 1462 |
| New Orleans, LA | P_A | psia | | | | | | | | | | | | | 14.69 |
| Shreveport, LA | T_{AN} | °F | 38.2 | 41.3 | 47.8 | 54.9 | 64.3 | 70.9 | 74 | 73.4 | 67.2 | 56.1 | 46 | 39.2 | 56.1 |
| Shreveport, LA | T_{AX} | °F | 57.2 | 61.4 | 68.5 | 76.1 | 83.3 | 89.6 | 92.9 | 93.3 | 87.6 | 77.8 | 66.5 | 58.4 | 76 |
| Shreveport, LA | V | mi/hr | 8.3 | 8.3 | 8.9 | 8.7 | 7.6 | 6.5 | 6 | 5.4 | 6.3 | 6.3 | 7.2 | 7.8 | 7.2 |
| Shreveport, LA | I | Btu/ft ² /day | 783 | 1001 | 1342 | 1709 | 1837 | 2007 | 2049 | 1915 | 1575 | 1251 | 884 | 732 | 1424 |
| Shreveport, LA | P_A | psia | | | | | | | | | | | | | 14.56 |
| Bangor, ME | T_{AN} | °F | 8.5 | 11.1 | 21.7 | 32.9 | 43.3 | 53.3 | 58.8 | 57.1 | 48.7 | 37.8 | 29.5 | 17.3 | 35 |
| Bangor, ME | T_{AX} | °F | 27 | 30.5 | 39.7 | 52.7 | 64.9 | 74.4 | 79.1 | 78.3 | 69.7 | 56.8 | 45.1 | 33.8 | 54.3 |
| Bangor, ME | V | mi/hr | 7.8 | 8.1 | 8.9 | 8.9 | 8.1 | 7.2 | 6.7 | 6.3 | 6.9 | 7.8 | 7.6 | 7.6 | 7.6 |
| Bangor, ME | I | Btu/ft ² /day | 496 | 752 | 1059 | 1410 | 1639 | 1762 | 1751 | 1585 | 1227 | 792 | 491 | 411 | 1115 |
| Bangor, ME | P_A | psia | | | | | | | | | | | | | 14.59 |

| | | | | | | | | | | | | | | | |
|---------------|----------|--------------------------|------|------|------|------|------|------|------|------|------|------|------|------|-------|
| Caribou, ME | T_{AN} | °F | 1.7 | 4.4 | 15.9 | 29.6 | 40.9 | 50.6 | 55.9 | 53.4 | 45.3 | 35.2 | 25.5 | 12.1 | 30.9 |
| Caribou, ME | T_{AX} | °F | 19 | 22.9 | 33.5 | 46.8 | 61.6 | 71.2 | 75.1 | 73.9 | 65.4 | 51.4 | 38.5 | 26.5 | 48.8 |
| Caribou, ME | V | mi/hr | 7.8 | 8.3 | 8.7 | 8.5 | 7.6 | 6.7 | 6 | 5.8 | 6.5 | 7.6 | 7.6 | 8.1 | 7.4 |
| Caribou, ME | I | Btu/ft ² /day | 428 | 674 | 1034 | 1390 | 1684 | 1800 | 1703 | 1542 | 1136 | 689 | 424 | 353 | 1071 |
| Caribou, ME | P_A | psia | | | | | | | | | | | | | 14.36 |
| Portland, ME | T_{AN} | °F | 14.9 | 17.1 | 25.8 | 35.3 | 44.8 | 54.8 | 60.2 | 59.2 | 51.5 | 40 | 31.9 | 21.9 | 38.1 |
| Portland, ME | T_{AX} | °F | 30.8 | 33.7 | 41.3 | 52.8 | 62.8 | 72.6 | 77.7 | 77.2 | 69.4 | 57.9 | 47.4 | 37.2 | 55.1 |
| Portland, ME | V | mi/hr | 8.1 | 8.5 | 9.2 | 9.2 | 8.1 | 7.2 | 6.7 | 6.5 | 6.9 | 7.6 | 7.6 | 8.1 | 7.8 |
| Portland, ME | I | Btu/ft ² /day | 530 | 803 | 1111 | 1471 | 1714 | 1838 | 1844 | 1688 | 1295 | 879 | 552 | 458 | 1182 |
| Portland, ME | P_A | psia | | | | | | | | | | | | | 14.66 |
| Baltimore, MD | T_{AN} | °F | 26.6 | 27.4 | 34.8 | 44.3 | 53.2 | 63.1 | 68 | 66.6 | 59.1 | 46.6 | 37.7 | 29.6 | 46.4 |
| Baltimore, MD | T_{AX} | °F | 42.2 | 44.7 | 53.5 | 65.1 | 73.9 | 82.8 | 86.9 | 85.3 | 78 | 66.7 | 56.2 | 45.5 | 65 |
| Baltimore, MD | V | mi/hr | 7.8 | 8.3 | 8.7 | 8.3 | 7.2 | 6.5 | 6 | 5.6 | 6.3 | 6.3 | 6.9 | 7.4 | 7.2 |
| Baltimore, MD | I | Btu/ft ² /day | 653 | 929 | 1231 | 1555 | 1774 | 1918 | 1866 | 1681 | 1350 | 1036 | 709 | 580 | 1274 |
| Baltimore, MD | P_A | psia | | | | | | | | | | | | | 14.62 |
| Boston, MA | T_{AN} | °F | 23.1 | 25 | 31.7 | 41.2 | 50.4 | 60.3 | 66 | 65.2 | 58.2 | 47.2 | 38.6 | 29.1 | 44.7 |
| Boston, MA | T_{AX} | °F | 36.2 | 38.3 | 45.1 | 55.8 | 65.7 | 75.8 | 80.8 | 79.3 | 72.1 | 61.3 | 51.1 | 41.4 | 58.6 |
| Boston, MA | V | mi/hr | 12.5 | 12.8 | 13 | 12.1 | 11.2 | 10.3 | 10.1 | 9.8 | 10.5 | 11.2 | 11.4 | 12.5 | 11.4 |
| Boston, MA | I | Btu/ft ² /day | 558 | 833 | 1113 | 1461 | 1703 | 1811 | 1830 | 1657 | 1284 | 913 | 576 | 475 | 1184 |
| Boston, MA | P_A | psia | | | | | | | | | | | | | 14.68 |
| Worcester, MA | T_{AN} | °F | 17.7 | 19.6 | 26.9 | 37.5 | 47.2 | 56.9 | 62 | 61.1 | 53.7 | 42.4 | 33.8 | 23.8 | 40.2 |
| Worcester, MA | T_{AX} | °F | 31.2 | 34 | 42.2 | 55 | 65.2 | 73.5 | 77.9 | 76.7 | 68.9 | 57.8 | 47.3 | 36.6 | 55.5 |
| Worcester, MA | V | mi/hr | 11.4 | 11.9 | 11.4 | 10.7 | 10.1 | 9.2 | 8.9 | 8.5 | 8.9 | 10.1 | 10.5 | 11.6 | 10.3 |
| Worcester, MA | I | Btu/ft ² /day | 567 | 821 | 1123 | 1454 | 1675 | 1764 | 1848 | 1619 | 1276 | 903 | 584 | 477 | 1176 |
| Worcester, MA | P_A | psia | | | | | | | | | | | | | 14.18 |
| Alpena, MI | T_{AN} | °F | 12.7 | 12.1 | 19.8 | 31.5 | 41.4 | 51.3 | 56.1 | 54.7 | 47.4 | 37.7 | 29.3 | 19.4 | 34.4 |
| Alpena, MI | T_{AX} | °F | 26.9 | 29.1 | 38.3 | 51.6 | 63.9 | 74.3 | 78 | 76.8 | 69.1 | 56.1 | 43.1 | 32.3 | 53.3 |
| Alpena, MI | V | mi/hr | 8.3 | 8.3 | 8.3 | 8.7 | 7.8 | 6.5 | 6.3 | 6 | 6.7 | 7.4 | 7.8 | 7.8 | 7.4 |
| Alpena, MI | I | Btu/ft ² /day | 401 | 653 | 1103 | 1457 | 1771 | 1948 | 1896 | 1632 | 1232 | 752 | 439 | 346 | 1136 |
| Alpena, MI | P_A | psia | | | | | | | | | | | | | 14.33 |

| | | | | | | | | | | | | | | | |
|----------------------|----------|--------------------------|------|------|------|------|------|------|------|------|------|------|------|------|-------|
| Detroit Metro AP, MI | T_{AN} | °F | 19.6 | 21.6 | 28.8 | 39.9 | 49.9 | 60.5 | 64.1 | 63.4 | 55.2 | 44 | 34.6 | 24.9 | 42.2 |
| Detroit Metro AP, MI | T_{AX} | °F | 31.9 | 34.9 | 45.4 | 58.7 | 69.1 | 78.9 | 82.3 | 80.7 | 73.7 | 61.4 | 48.1 | 36.1 | 58.4 |
| Detroit Metro AP, MI | V | mi/hr | 11 | 10.3 | 10.1 | 10.3 | 8.9 | 8.1 | 8.1 | 7.2 | 7.6 | 9.2 | 10.1 | 10.3 | 9.2 |
| Detroit Metro AP, MI | I | Btu/ft ² /day | 479 | 755 | 1117 | 1442 | 1738 | 1922 | 1896 | 1620 | 1332 | 861 | 510 | 400 | 1173 |
| Detroit Metro AP, MI | P_A | psia | | | | | | | | | | | | | 14.36 |
| Detroit - City, MI | T_{AN} | °F | 20.9 | 22.5 | 29.3 | 40.1 | 50.3 | 61.1 | 65.5 | 64.6 | 56.6 | 45.4 | 35.8 | 26.1 | 43.2 |
| Detroit - City, MI | T_{AX} | °F | 32.3 | 35.3 | 45 | 58.1 | 68.9 | 79 | 82.8 | 81 | 73.8 | 61.2 | 48.1 | 36.5 | 58.5 |
| Detroit - City, MI | V | mi/hr | 10.1 | 9.8 | 9.6 | 9.8 | 8.7 | 7.6 | 7.6 | 6.9 | 7.4 | 8.5 | 9.2 | 9.6 | 8.7 |
| Detroit - City, MI | I | Btu/ft ² /day | 469 | 746 | 1120 | 1437 | 1711 | 1884 | 1850 | 1585 | 1316 | 870 | 507 | 409 | 1159 |
| Detroit - City, MI | P_A | psia | | | | | | | | | | | | | 14.36 |
| Flint, MI | T_{AN} | °F | 16.7 | 18.2 | 25.7 | 36.6 | 46.6 | 56.9 | 60 | 59.1 | 50.8 | 40.8 | 32 | 22.3 | 38.8 |
| Flint, MI | T_{AX} | °F | 29.8 | 33 | 43.4 | 57.1 | 68.1 | 77.9 | 81.1 | 79.4 | 72.4 | 59.7 | 46.5 | 34.4 | 56.9 |
| Flint, MI | V | mi/hr | 10.3 | 10.3 | 10.3 | 10.5 | 9.2 | 7.6 | 7.4 | 6.9 | 7.6 | 8.9 | 9.6 | 9.6 | 8.9 |
| Flint, MI | I | Btu/ft ² /day | 440 | 713 | 1104 | 1474 | 1747 | 1947 | 1921 | 1635 | 1309 | 839 | 491 | 394 | 1168 |
| Flint, MI | P_A | psia | | | | | | | | | | | | | 14.29 |
| Grand Rapids, MI | T_{AN} | °F | 18.2 | 19.7 | 26.7 | 37.5 | 47.8 | 58 | 61.7 | 60.8 | 52.4 | 41.8 | 32.6 | 23.7 | 40.1 |
| Grand Rapids, MI | T_{AX} | °F | 29.8 | 32.8 | 43.4 | 57.2 | 68.2 | 77.9 | 81.1 | 79.4 | 72.2 | 59.5 | 46.1 | 34.4 | 56.8 |
| Grand Rapids, MI | V | mi/hr | 11 | 10.5 | 10.5 | 11 | 9.8 | 8.3 | 8.1 | 7.4 | 7.8 | 9.4 | 10.1 | 10.3 | 9.6 |
| Grand Rapids, MI | I | Btu/ft ² /day | 405 | 684 | 1109 | 1461 | 1746 | 1943 | 1913 | 1635 | 1306 | 819 | 487 | 367 | 1156 |
| Grand Rapids, MI | P_A | psia | | | | | | | | | | | | | 14.27 |
| Houghton Lake, MI | T_{AN} | °F | 12.3 | 12.3 | 20.3 | 32.1 | 42.9 | 52.2 | 55.7 | 54.2 | 46.6 | 37.7 | 29 | 19.2 | 34.5 |
| Houghton Lake, MI | T_{AX} | °F | 26.1 | 29.1 | 39.7 | 53.5 | 65.5 | 75.5 | 78.6 | 76.9 | 69.1 | 55.8 | 42.3 | 31 | 53.6 |
| Houghton Lake, MI | V | mi/hr | 8.7 | 8.3 | 8.3 | 9.2 | 8.3 | 6.9 | 6.7 | 6.5 | 6.9 | 8.1 | 8.7 | 8.7 | 7.8 |
| Houghton Lake, MI | I | Btu/ft ² /day | 401 | 646 | 1089 | 1462 | 1708 | 1894 | 1874 | 1593 | 1219 | 763 | 439 | 363 | 1121 |
| Houghton Lake, MI | P_A | psia | | | | | | | | | | | | | 14.1 |
| Lansing, MI | T_{AN} | °F | 16.5 | 17.9 | 25.4 | 36.2 | 46.2 | 56.4 | 59.5 | 58.7 | 50.3 | 40.4 | 31.7 | 22.1 | 38.4 |
| Lansing, MI | T_{AX} | °F | 29.8 | 32.9 | 43.6 | 57.3 | 67.9 | 77.7 | 81 | 79.2 | 72.3 | 59.6 | 46.3 | 34.3 | 56.8 |

| | | | | | | | | | | | | | | | |
|-------------------------|-----------------------|--------------------------|------|------|------|------|------|------|------|------|------|------|------|------|-------|
| Lansing, MI | <i>V</i> | mi/hr | 10.3 | 10.1 | 9.8 | 10.1 | 8.9 | 7.6 | 7.4 | 6.7 | 7.2 | 8.7 | 9.6 | 10.1 | 8.9 |
| Lansing, MI | <i>I</i> | Btu/ft ² /day | 459 | 729 | 1109 | 1441 | 1707 | 1905 | 1863 | 1595 | 1303 | 833 | 494 | 398 | 1153 |
| Lansing, MI | <i>P_A</i> | psia | | | | | | | | | | | | | 14.26 |
| Muskegon, MI | <i>T_{AN}</i> | °F | 20.2 | 20.8 | 26.7 | 37 | 46.7 | 56.7 | 61.3 | 60.8 | 52.4 | 42.6 | 33.7 | 25.2 | 40.3 |
| Muskegon, MI | <i>T_{AX}</i> | °F | 30.6 | 33.1 | 42.5 | 55.2 | 65.9 | 75.3 | 78.9 | 77.9 | 70.9 | 58.5 | 45.9 | 35.2 | 55.8 |
| Muskegon, MI | <i>V</i> | mi/hr | 11.2 | 10.7 | 10.3 | 10.7 | 9.4 | 8.3 | 8.1 | 7.8 | 8.3 | 9.8 | 11 | 11 | 9.6 |
| Muskegon, MI | <i>I</i> | Btu/ft ² /day | 391 | 659 | 1102 | 1479 | 1775 | 1986 | 1962 | 1671 | 1290 | 809 | 451 | 339 | 1160 |
| Muskegon, MI | <i>P_A</i> | psia | | | | | | | | | | | | | 14.36 |
| Sault Ste Marie, MI | <i>T_{AN}</i> | °F | 8.1 | 9.5 | 18.2 | 30.9 | 40.9 | 49.8 | 54.8 | 55 | 48.4 | 38.3 | 28.5 | 17 | 33.3 |
| Sault Ste Marie, MI | <i>T_{AX}</i> | °F | 22.2 | 25.2 | 34.2 | 47.8 | 61.1 | 70.8 | 74.2 | 73.8 | 65.8 | 52.4 | 39.6 | 29 | 49.7 |
| Sault Ste Marie, MI | <i>V</i> | mi/hr | 7.8 | 7.8 | 8.1 | 8.7 | 8.5 | 7.2 | 6.9 | 6.7 | 7.2 | 7.8 | 8.5 | 8.1 | 7.8 |
| Sault Ste Marie, MI | <i>I</i> | Btu/ft ² /day | 357 | 617 | 1042 | 1473 | 1794 | 1962 | 1837 | 1611 | 1128 | 677 | 378 | 291 | 1097 |
| Sault Ste Marie, MI | <i>P_A</i> | psia | | | | | | | | | | | | | 14.32 |
| Traverse City, MI | <i>T_{AN}</i> | °F | 17 | 16.5 | 23.3 | 33.3 | 43.2 | 54.2 | 58.7 | 58.2 | 51 | 40.9 | 31.7 | 22.8 | 37.6 |
| Traverse City, MI | <i>T_{AX}</i> | °F | 28.3 | 30.6 | 40.3 | 53.7 | 65.6 | 75.9 | 79.4 | 78 | 70.4 | 57.5 | 44.3 | 33.4 | 54.8 |
| Traverse City, MI | <i>V</i> | mi/hr | 8.3 | 8.3 | 7.6 | 8.1 | 6.9 | 6.3 | 6.5 | 6 | 6.5 | 7.6 | 8.1 | 7.8 | 7.4 |
| Traverse City, MI | <i>I</i> | Btu/ft ² /day | 403 | 648 | 1101 | 1462 | 1756 | 1921 | 1874 | 1619 | 1210 | 725 | 405 | 339 | 1122 |
| Traverse City, MI | <i>P_A</i> | psia | | | | | | | | | | | | | 14.37 |
| Duluth, MN | <i>T_{AN}</i> | °F | 2.6 | 7.1 | 18.2 | 30.7 | 41.4 | 50.6 | 55.9 | 55.4 | 47.2 | 35.7 | 23 | 9.4 | 31.4 |
| Duluth, MN | <i>T_{AX}</i> | °F | 18.5 | 23.9 | 34.3 | 48 | 61 | 69.8 | 74.7 | 73.6 | 64.7 | 51 | 35.6 | 23 | 48.2 |
| Duluth, MN | <i>V</i> | mi/hr | 10.5 | 10.3 | 10.5 | 11 | 10.7 | 9.4 | 8.7 | 8.7 | 9.6 | 10.5 | 10.7 | 10.3 | 10.1 |
| Duluth, MN | <i>I</i> | Btu/ft ² /day | 461 | 707 | 1083 | 1499 | 1770 | 1844 | 1899 | 1627 | 1179 | 724 | 441 | 365 | 1133 |
| Duluth, MN | <i>P_A</i> | psia | | | | | | | | | | | | | 13.95 |
| International Falls, MN | <i>T_{AN}</i> | °F | -4.5 | 0.3 | 13.7 | 28.4 | 39.8 | 50 | 53.4 | 51.8 | 43.2 | 32.5 | 19.4 | 3.7 | 27.6 |
| International Falls, MN | <i>T_{AX}</i> | °F | 15 | 21.9 | 34.5 | 50.4 | 63.3 | 72.4 | 76.2 | 75 | 65.4 | 50.6 | 33.8 | 20 | 48.2 |
| International Falls, MN | <i>V</i> | mi/hr | 7.8 | 7.8 | 8.5 | 8.5 | 8.7 | 7.6 | 6.9 | 6.7 | 7.6 | 8.3 | 8.3 | 7.6 | 7.8 |
| International Falls, MN | <i>I</i> | Btu/ft ² /day | 402 | 667 | 1041 | 1501 | 1708 | 1788 | 1807 | 1574 | 1102 | 657 | 375 | 300 | 1077 |

| | | | | | | | | | | | | | | | |
|-------------------------|----------|--------------------------|------|------|------|------|------|------|------|------|------|------|------|------|-------|
| International Falls, MN | P_A | psia | | | | | | | | | | | | | 14.08 |
| Minneapolis-St Paul, MN | T_{AN} | °F | 8.3 | 13.6 | 24.6 | 37.9 | 49.6 | 59.7 | 64.5 | 62.5 | 53.3 | 40.9 | 27.5 | 14.4 | 38.1 |
| Minneapolis-St Paul, MN | T_{AX} | °F | 22.8 | 28.5 | 40.6 | 56.7 | 68.3 | 77.8 | 81.9 | 79.8 | 71.5 | 57.8 | 41 | 27.7 | 54.5 |
| Minneapolis-St Paul, MN | V | mi/hr | 9.4 | 9.4 | 9.8 | 10.7 | 10.3 | 9.2 | 8.5 | 8.3 | 9.2 | 9.8 | 9.6 | 9.2 | 9.4 |
| Minneapolis-St Paul, MN | I | Btu/ft ² /day | 490 | 752 | 1116 | 1476 | 1712 | 1856 | 1930 | 1655 | 1265 | 814 | 501 | 389 | 1163 |
| Minneapolis-St Paul, MN | P_A | psia | | | | | | | | | | | | | 14.26 |
| Rochester, MN | T_{AN} | °F | 7.3 | 12.2 | 23.6 | 36 | 47.4 | 57.5 | 60.7 | 58.8 | 50.1 | 38.6 | 26.2 | 13.3 | 36 |
| Rochester, MN | T_{AX} | °F | 21.8 | 26.8 | 39.1 | 55.3 | 67 | 76.4 | 79 | 77 | 70.3 | 57.4 | 40.7 | 27.1 | 53.2 |
| Rochester, MN | V | mi/hr | 13 | 13 | 13 | 13.4 | 12.8 | 10.7 | 9.6 | 8.9 | 10.3 | 11.6 | 12.8 | 13 | 11.9 |
| Rochester, MN | I | Btu/ft ² /day | 474 | 708 | 1106 | 1489 | 1709 | 1891 | 1955 | 1664 | 1286 | 848 | 513 | 384 | 1169 |
| Rochester, MN | P_A | psia | | | | | | | | | | | | | 14.01 |
| St Cloud, MN | T_{AN} | °F | 2.8 | 7.8 | 20.1 | 33.1 | 44.5 | 54.8 | 58.6 | 56.5 | 47.6 | 35.9 | 23.1 | 9.6 | 32.9 |
| St Cloud, MN | T_{AX} | °F | 20.4 | 26.3 | 38.2 | 55 | 67.6 | 76.4 | 80.7 | 78.8 | 70.3 | 56.2 | 38.9 | 25.4 | 52.9 |
| St Cloud, MN | V | mi/hr | 8.3 | 8.3 | 8.7 | 9.4 | 9.2 | 7.8 | 6.7 | 6.5 | 7.4 | 8.5 | 8.5 | 8.3 | 8.1 |
| St Cloud, MN | I | Btu/ft ² /day | 453 | 700 | 1094 | 1527 | 1754 | 1906 | 1967 | 1669 | 1259 | 802 | 481 | 367 | 1165 |
| St Cloud, MN | P_A | psia | | | | | | | | | | | | | 14.16 |
| Jackson, MS | T_{AN} | °F | 37 | 39.3 | 45.9 | 53.3 | 62.5 | 69.2 | 72.1 | 71.4 | 65.5 | 53.9 | 43.9 | 37.9 | 54.3 |
| Jackson, MS | T_{AX} | °F | 56.5 | 60.8 | 68.1 | 75.7 | 83 | 89 | 91.1 | 91.2 | 86.5 | 77.1 | 66.3 | 58.1 | 75.3 |
| Jackson, MS | V | mi/hr | 6.7 | 6.9 | 7.2 | 6.7 | 5.6 | 4.7 | 4 | 4 | 5.1 | 5.1 | 5.4 | 6.3 | 5.6 |
| Jackson, MS | I | Btu/ft ² /day | 783 | 1039 | 1369 | 1762 | 1929 | 2025 | 1969 | 1849 | 1576 | 1262 | 922 | 726 | 1434 |
| Jackson, MS | P_A | psia | | | | | | | | | | | | | 14.53 |
| Meridian, MS | T_{AN} | °F | 35.8 | 38.1 | 44.5 | 51.5 | 60.8 | 67.8 | 70.8 | 70.2 | 64.2 | 52.5 | 42.5 | 36.9 | 53 |
| Meridian, MS | T_{AX} | °F | 57.1 | 61.4 | 68.8 | 76.2 | 83.4 | 88.8 | 91.4 | 91.1 | 86.5 | 77.3 | 66.9 | 58.5 | 75.6 |
| Meridian, MS | V | mi/hr | 6.9 | 7.2 | 7.4 | 6.9 | 5.8 | 4.9 | 4.5 | 4.3 | 5.1 | 5.1 | 5.6 | 6.3 | 5.8 |
| Meridian, MS | I | Btu/ft ² /day | 783 | 1044 | 1380 | 1726 | 1918 | 1989 | 1945 | 1823 | 1544 | 1252 | 924 | 727 | 1421 |
| Meridian, MS | P_A | psia | | | | | | | | | | | | | 14.53 |
| Tupelo, MS | T_{AN} | °F | 33.2 | 35.9 | 43 | 51 | 60.2 | 68.1 | 71.5 | 70.6 | 63.4 | 51.6 | 42 | 34.8 | 52.1 |
| Tupelo, MS | T_{AX} | °F | 51.3 | 55.8 | 64.3 | 73 | 80.6 | 87.4 | 90.1 | 90.1 | 84.2 | 74.2 | 62.9 | 52.8 | 72.2 |

| | | | | | | | | | | | | | | | |
|------------------------|-----------------------|--------------------------|------|------|------|------|------|------|------|------|------|------|------|------|-------|
| Tupelo, MS | <i>V</i> | mi/hr | 7.6 | 7.8 | 8.1 | 7.6 | 6.3 | 5.4 | 4.7 | 4.7 | 5.6 | 5.6 | 6 | 6.9 | 6.3 |
| Tupelo, MS | <i>I</i> | Btu/ft ² /day | 730 | 964 | 1309 | 1682 | 1912 | 2026 | 1990 | 1849 | 1536 | 1201 | 832 | 648 | 1390 |
| Tupelo, MS | <i>P_A</i> | psia | | | | | | | | | | | | | 14.5 |
| Columbia, MO | <i>T_{AN}</i> | °F | 21.4 | 26 | 34.2 | 44.8 | 54.6 | 63.3 | 67.3 | 65.9 | 56.7 | 46 | 35.4 | 25.3 | 45.1 |
| Columbia, MO | <i>T_{AX}</i> | °F | 37.6 | 43.9 | 54.5 | 65.4 | 74 | 82.2 | 86.6 | 86.5 | 77.8 | 66.7 | 53.2 | 41.4 | 64.2 |
| Columbia, MO | <i>V</i> | mi/hr | 10.3 | 10.5 | 11.2 | 11.2 | 9.2 | 8.1 | 7.4 | 7.2 | 7.8 | 9.2 | 10.1 | 10.1 | 9.4 |
| Columbia, MO | <i>I</i> | Btu/ft ² /day | 629 | 886 | 1251 | 1575 | 1808 | 2033 | 2027 | 1823 | 1490 | 1070 | 690 | 556 | 1320 |
| Columbia, MO | <i>P_A</i> | psia | | | | | | | | | | | | | 14.23 |
| Kansas City, MO | <i>T_{AN}</i> | °F | 20.4 | 25.2 | 33.9 | 44.9 | 55.1 | 64.3 | 68.8 | 67.5 | 57.6 | 46.8 | 34.9 | 24.5 | 45.3 |
| Kansas City, MO | <i>T_{AX}</i> | °F | 37.1 | 43.4 | 54.2 | 64.8 | 74.2 | 82.7 | 87.2 | 86.8 | 78.1 | 66.5 | 52.5 | 40.8 | 64 |
| Kansas City, MO | <i>V</i> | mi/hr | 10.7 | 10.7 | 11.9 | 12.3 | 10.3 | 9.6 | 8.7 | 8.5 | 9.2 | 10.3 | 10.7 | 10.5 | 10.3 |
| Kansas City, MO | <i>I</i> | Btu/ft ² /day | 641 | 929 | 1273 | 1566 | 1815 | 1999 | 2028 | 1823 | 1488 | 1074 | 701 | 566 | 1325 |
| Kansas City, MO | <i>P_A</i> | psia | | | | | | | | | | | | | 14.18 |
| Springfield, MO | <i>T_{AN}</i> | °F | 24.3 | 28.5 | 35.8 | 45.6 | 55.5 | 63.9 | 68.3 | 67.3 | 58.2 | 47.3 | 36.6 | 27.1 | 46.5 |
| Springfield, MO | <i>T_{AX}</i> | °F | 42.3 | 48.2 | 56.8 | 66.6 | 74.5 | 82.9 | 87.4 | 87.9 | 79.2 | 68.4 | 55.7 | 44.8 | 66.2 |
| Springfield, MO | <i>V</i> | mi/hr | 9.8 | 10.1 | 11 | 10.7 | 8.9 | 8.1 | 7.2 | 7.2 | 7.8 | 8.9 | 9.8 | 9.8 | 9.2 |
| Springfield, MO | <i>I</i> | Btu/ft ² /day | 677 | 929 | 1242 | 1593 | 1783 | 1996 | 2030 | 1868 | 1494 | 1129 | 742 | 601 | 1340 |
| Springfield, MO | <i>P_A</i> | psia | | | | | | | | | | | | | 14.04 |
| St Louis - Lambert, MO | <i>T_{AN}</i> | °F | 24.6 | 28.7 | 37.2 | 47.9 | 58.2 | 67.2 | 71.3 | 70 | 60.9 | 49.6 | 38.5 | 28.5 | 48.5 |
| St Louis - Lambert, MO | <i>T_{AX}</i> | °F | 39.2 | 45.1 | 55.5 | 67 | 75.7 | 84.3 | 88.1 | 87.3 | 79.4 | 68.2 | 54.7 | 42.8 | 65.6 |
| St Louis - Lambert, MO | <i>V</i> | mi/hr | 9.8 | 10.1 | 10.5 | 10.5 | 9.2 | 8.1 | 7.6 | 7.2 | 7.4 | 8.5 | 9.4 | 9.6 | 8.9 |
| St Louis - Lambert, MO | <i>I</i> | Btu/ft ² /day | 598 | 882 | 1217 | 1557 | 1765 | 2007 | 1978 | 1802 | 1471 | 1076 | 703 | 537 | 1299 |
| St Louis - Lambert, MO | <i>P_A</i> | psia | | | | | | | | | | | | | 14.39 |
| St Louis - Spirit, MO | <i>T_{AN}</i> | °F | 22.6 | 26.7 | 34.6 | 44.9 | 55 | 63.9 | 67.9 | 66 | 56.3 | 45.4 | 35.4 | 26.2 | 45.4 |
| St Louis - Spirit, MO | <i>T_{AX}</i> | °F | 39.6 | 45.5 | 56.3 | 67.5 | 75.8 | 84.1 | 88 | 87.2 | 79.4 | 68.6 | 55.3 | 43.3 | 65.9 |
| St Louis - Spirit, MO | <i>V</i> | mi/hr | 8.1 | 8.1 | 8.5 | 8.7 | 6.7 | 5.8 | 5.4 | 4.9 | 4.9 | 6.3 | 7.4 | 7.4 | 6.9 |
| St Louis - Spirit, MO | <i>I</i> | Btu/ft ² /day | 604 | 888 | 1226 | 1570 | 1763 | 2009 | 1992 | 1811 | 1467 | 1073 | 694 | 545 | 1303 |

| | | | | | | | | | | | | | | | |
|-----------------------|----------|--------------------------|------|------|------|------|------|------|------|------|------|------|------|------|-------|
| St Louis - Spirit, MO | P_A | psia | | | | | | | | | | | | | 14.45 |
| Billings, MT | T_{AN} | °F | 18 | 21.8 | 27.3 | 35.2 | 44.2 | 52.5 | 59.6 | 58 | 48.8 | 37.7 | 27.3 | 19.6 | 37.5 |
| Billings, MT | T_{AX} | °F | 34.9 | 40.1 | 48 | 56.1 | 66.4 | 75.1 | 85.7 | 84.8 | 73 | 58.1 | 44.8 | 35.3 | 58.5 |
| Billings, MT | V | mi/hr | 12.8 | 11.6 | 10.7 | 10.5 | 9.8 | 9.4 | 8.9 | 8.9 | 9.4 | 10.5 | 11.9 | 12.5 | 10.5 |
| Billings, MT | I | Btu/ft ² /day | 478 | 784 | 1148 | 1514 | 1883 | 2048 | 2221 | 1912 | 1424 | 903 | 544 | 398 | 1271 |
| Billings, MT | P_A | psia | | | | | | | | | | | | | 12.92 |
| Glasgow, MT | T_{AN} | °F | 3.8 | 9.8 | 20.6 | 32.3 | 42.2 | 51.5 | 57.4 | 56.3 | 45.6 | 32.9 | 19.9 | 8.3 | 31.7 |
| Glasgow, MT | T_{AX} | °F | 21.7 | 28.4 | 41.4 | 56.4 | 66.5 | 74.7 | 83.9 | 83.7 | 72.1 | 55.9 | 39.4 | 26.3 | 54.2 |
| Glasgow, MT | V | mi/hr | 9.4 | 9.4 | 11 | 12.1 | 12.1 | 11 | 10.1 | 10.7 | 10.3 | 10.3 | 9.6 | 9.4 | 10.5 |
| Glasgow, MT | I | Btu/ft ² /day | 366 | 628 | 1068 | 1545 | 1889 | 2051 | 2180 | 1872 | 1340 | 834 | 444 | 311 | 1211 |
| Glasgow, MT | P_A | psia | | | | | | | | | | | | | 13.53 |
| Great Falls, MT | T_{AN} | °F | 15.9 | 18.8 | 23.7 | 31.6 | 39.9 | 47 | 53 | 51.7 | 44 | 34.2 | 25.2 | 17.7 | 33.5 |
| Great Falls, MT | T_{AX} | °F | 34.1 | 38.1 | 45.2 | 53.9 | 63.7 | 71.1 | 82.7 | 81.5 | 70.5 | 56.5 | 42.7 | 35 | 56.2 |
| Great Falls, MT | V | mi/hr | 13.4 | 11.9 | 11.9 | 11.2 | 10.5 | 9.8 | 8.9 | 8.9 | 10.1 | 11.9 | 13.4 | 13.6 | 11.4 |
| Great Falls, MT | I | Btu/ft ² /day | 428 | 706 | 1106 | 1450 | 1806 | 2001 | 2163 | 1857 | 1360 | 840 | 465 | 358 | 1212 |
| Great Falls, MT | P_A | psia | | | | | | | | | | | | | 12.88 |
| Harve City, MT | T_{AN} | °F | 6.4 | 12 | 20.7 | 31.4 | 40.8 | 48.9 | 54.1 | 52.5 | 42.6 | 31.1 | 20.4 | 9.9 | 30.9 |
| Harve City, MT | T_{AX} | °F | 26.6 | 33.1 | 43.8 | 56.9 | 66.4 | 74 | 84.3 | 83.5 | 72 | 57.3 | 41.6 | 30.6 | 55.8 |
| Harve City, MT | V | mi/hr | 9.6 | 9.2 | 9.8 | 10.5 | 10.5 | 9.6 | 8.7 | 8.7 | 8.9 | 9.4 | 10.1 | 9.8 | 9.6 |
| Harve City, MT | I | Btu/ft ² /day | 371 | 632 | 1091 | 1522 | 1828 | 2035 | 2166 | 1862 | 1333 | 826 | 435 | 318 | 1202 |
| Harve City, MT | P_A | psia | | | | | | | | | | | | | 13.39 |
| Helena, MT | T_{AN} | °F | 13.5 | 18.4 | 24.9 | 32.8 | 41.8 | 49 | 55.3 | 53 | 44.4 | 33.5 | 23.1 | 14.5 | 33.7 |
| Helena, MT | T_{AX} | °F | 31.2 | 37.6 | 46.8 | 55.6 | 65.6 | 73.3 | 84.6 | 83.3 | 72.2 | 57 | 41.8 | 31.6 | 56.7 |
| Helena, MT | V | mi/hr | 5.6 | 6 | 7.4 | 8.3 | 8.1 | 7.8 | 7.2 | 6.5 | 6.3 | 6.5 | 6 | 5.6 | 6.7 |
| Helena, MT | I | Btu/ft ² /day | 456 | 767 | 1185 | 1513 | 1832 | 2048 | 2214 | 1898 | 1420 | 889 | 503 | 390 | 1260 |
| Helena, MT | P_A | psia | | | | | | | | | | | | | 12.79 |
| Kalispell, MT | T_{AN} | °F | 17.2 | 20 | 25.5 | 31.9 | 39.4 | 45.2 | 49.1 | 47.2 | 39.6 | 30.5 | 24.8 | 18.3 | 32.4 |
| Kalispell, MT | T_{AX} | °F | 30.2 | 35.6 | 44.4 | 54.4 | 64 | 70 | 80.7 | 80.3 | 69.5 | 53.9 | 39.1 | 30 | 54.4 |
| Kalispell, MT | V | mi/hr | 4 | 4.3 | 5.8 | 6.7 | 6.5 | 5.8 | 5.4 | 5.1 | 4.7 | 4.5 | 4 | 3.8 | 5.1 |

| | | | | | | | | | | | | | | | |
|------------------|-----------------------|--------------------------|------|------|------|------|------|------|------|------|------|------|------|------|-------|
| Kalispell, MT | <i>I</i> | Btu/ft ² /day | 322 | 605 | 1031 | 1440 | 1761 | 1895 | 2166 | 1812 | 1300 | 742 | 377 | 259 | 1142 |
| Kalispell, MT | <i>P_A</i> | psia | | | | | | | | | | | | | 13.2 |
| Missoula, MT | <i>T_{AN}</i> | °F | 19 | 22.1 | 27.8 | 33.2 | 40.5 | 47 | 52.7 | 50.9 | 43 | 33.4 | 25.3 | 19 | 34.5 |
| Missoula, MT | <i>T_{AX}</i> | °F | 31.5 | 37.6 | 48 | 55.9 | 65.6 | 72.4 | 84.7 | 83.5 | 72.2 | 56 | 39.9 | 30.8 | 56.5 |
| Missoula, MT | <i>V</i> | mi/hr | 3.8 | 4.3 | 5.8 | 6.5 | 6.3 | 6.5 | 6.3 | 5.8 | 4.9 | 4.5 | 4 | 4 | 5.1 |
| Missoula, MT | <i>I</i> | Btu/ft ² /day | 387 | 676 | 1088 | 1451 | 1787 | 1966 | 2229 | 1883 | 1385 | 820 | 428 | 315 | 1201 |
| Missoula, MT | <i>P_A</i> | psia | | | | | | | | | | | | | 13.1 |
| Grand Island, NE | <i>T_{AN}</i> | °F | 14.9 | 19.4 | 28 | 38.4 | 50.2 | 60 | 65.1 | 63.2 | 52.8 | 40.4 | 27.6 | 18.3 | 39.9 |
| Grand Island, NE | <i>T_{AX}</i> | °F | 34.7 | 39.7 | 50.4 | 61.8 | 72 | 81.9 | 86.5 | 84.7 | 77.6 | 64.3 | 49.1 | 37.4 | 61.7 |
| Grand Island, NE | <i>V</i> | mi/hr | 11 | 11.4 | 12.5 | 13.4 | 12.1 | 10.7 | 9.2 | 8.9 | 10.5 | 11.2 | 11.2 | 11 | 11.2 |
| Grand Island, NE | <i>I</i> | Btu/ft ² /day | 637 | 908 | 1284 | 1619 | 1846 | 2102 | 2100 | 1855 | 1492 | 1080 | 711 | 554 | 1349 |
| Grand Island, NE | <i>P_A</i> | psia | | | | | | | | | | | | | 13.75 |
| Lincoln, NE | <i>T_{AN}</i> | °F | 14.3 | 19.3 | 28.4 | 39.5 | 51.1 | 61.6 | 66.5 | 64.2 | 53.6 | 41.4 | 28.4 | 18.1 | 40.5 |
| Lincoln, NE | <i>T_{AX}</i> | °F | 34.1 | 39.8 | 51.5 | 63.2 | 73.5 | 82.9 | 87.8 | 86.1 | 78.3 | 65.4 | 49.7 | 37.8 | 62.5 |
| Lincoln, NE | <i>V</i> | mi/hr | 8.9 | 9.6 | 11 | 11.9 | 10.5 | 9.6 | 8.7 | 8.3 | 9.2 | 9.6 | 9.4 | 8.9 | 9.6 |
| Lincoln, NE | <i>I</i> | Btu/ft ² /day | 591 | 872 | 1205 | 1555 | 1782 | 1994 | 2017 | 1784 | 1465 | 1030 | 663 | 521 | 1290 |
| Lincoln, NE | <i>P_A</i> | psia | | | | | | | | | | | | | 14.08 |
| Norfolk, NE | <i>T_{AN}</i> | °F | 13 | 18 | 26.9 | 38.1 | 49.2 | 59.4 | 64.1 | 62.2 | 52 | 39.7 | 26.7 | 16.8 | 38.8 |
| Norfolk, NE | <i>T_{AX}</i> | °F | 31.9 | 37.1 | 48.3 | 60.8 | 71.7 | 80.9 | 85.5 | 83.5 | 76.3 | 63.2 | 47.2 | 34.8 | 60.1 |
| Norfolk, NE | <i>V</i> | mi/hr | 10.5 | 11 | 11.6 | 12.5 | 11.2 | 9.8 | 8.9 | 8.7 | 9.8 | 10.3 | 10.5 | 10.5 | 10.5 |
| Norfolk, NE | <i>I</i> | Btu/ft ² /day | 566 | 836 | 1226 | 1556 | 1807 | 2036 | 2063 | 1794 | 1452 | 1012 | 647 | 507 | 1292 |
| Norfolk, NE | <i>P_A</i> | psia | | | | | | | | | | | | | 13.89 |
| North Platte, NE | <i>T_{AN}</i> | °F | 12.7 | 16.5 | 24.5 | 34.2 | 45.3 | 55.5 | 61.7 | 59.7 | 48.3 | 35 | 22.3 | 14.1 | 35.8 |
| North Platte, NE | <i>T_{AX}</i> | °F | 38.7 | 43 | 52.1 | 60.8 | 71.1 | 80.7 | 87.2 | 85.1 | 77.3 | 63.7 | 49.9 | 40 | 62.5 |
| North Platte, NE | <i>V</i> | mi/hr | 8.3 | 8.9 | 10.3 | 11.4 | 10.3 | 9.4 | 8.5 | 8.1 | 8.9 | 8.9 | 8.7 | 8.3 | 9.2 |
| North Platte, NE | <i>I</i> | Btu/ft ² /day | 666 | 938 | 1324 | 1642 | 1899 | 2170 | 2191 | 1905 | 1546 | 1097 | 710 | 587 | 1390 |
| North Platte, NE | <i>P_A</i> | psia | | | | | | | | | | | | | 13.29 |
| Omaha, NE | <i>T_{AN}</i> | °F | 14.2 | 19.5 | 28.8 | 40.7 | 52 | 62.1 | 67 | 64.8 | 54.6 | 42.7 | 29.8 | 18.9 | 41.3 |
| Omaha, NE | <i>T_{AX}</i> | °F | 31.7 | 37.7 | 49.9 | 62.7 | 73 | 82.3 | 86.2 | 84.4 | 77.2 | 64.5 | 48.4 | 35.9 | 61.2 |
| Omaha, NE | <i>V</i> | mi/hr | 10.1 | 10.3 | 11.2 | 11.9 | 10.5 | 9.4 | 8.3 | 8.1 | 8.9 | 9.6 | 10.1 | 9.8 | 9.8 |

| | | | | | | | | | | | | | | | |
|-----------------|-----------------------|--------------------------|------|------|------|------|------|------|-------|-------|------|------|------|------|-------|
| Omaha, NE | <i>I</i> | Btu/ft ² /day | 582 | 852 | 1204 | 1512 | 1776 | 1992 | 2001 | 1749 | 1447 | 1007 | 646 | 506 | 1273 |
| Omaha, NE | <i>P_A</i> | psia | | | | | | | | | | | | | 14.18 |
| Scottsbluff, NE | <i>T_{AN}</i> | °F | 14.8 | 17.7 | 24.6 | 32.6 | 43.5 | 52.9 | 59.1 | 57.1 | 46.2 | 33.7 | 22.5 | 14.9 | 35 |
| Scottsbluff, NE | <i>T_{AX}</i> | °F | 39.8 | 44 | 52.2 | 60 | 70.8 | 80.8 | 88.7 | 86.5 | 77.2 | 63 | 49.2 | 40.1 | 62.7 |
| Scottsbluff, NE | <i>V</i> | mi/hr | 9.6 | 10.3 | 11 | 11.4 | 11 | 9.8 | 8.5 | 8.3 | 8.3 | 9.2 | 9.4 | 9.4 | 9.6 |
| Scottsbluff, NE | <i>I</i> | Btu/ft ² /day | 672 | 923 | 1295 | 1647 | 1955 | 2180 | 2261 | 1963 | 1571 | 1089 | 715 | 559 | 1403 |
| Scottsbluff, NE | <i>P_A</i> | psia | | | | | | | | | | | | | 12.75 |
| Valentine, NE | <i>T_{AN}</i> | °F | 11.5 | 15.7 | 23.8 | 33.8 | 44.6 | 54.7 | 60.8 | 59.2 | 48.3 | 34.8 | 22.2 | 13.5 | 35.2 |
| Valentine, NE | <i>T_{AX}</i> | °F | 35.5 | 39.5 | 48.6 | 58.8 | 69.9 | 79.4 | 87.3 | 86.1 | 76.7 | 62 | 47.4 | 37.2 | 60.7 |
| Valentine, NE | <i>V</i> | mi/hr | 9.4 | 9.8 | 10.5 | 11.4 | 11.4 | 10.3 | 9.2 | 9.6 | 10.3 | 10.1 | 9.8 | 9.6 | 10.1 |
| Valentine, NE | <i>I</i> | Btu/ft ² /day | 601 | 853 | 1215 | 1539 | 1862 | 2066 | 2187 | 1883 | 1496 | 1011 | 643 | 514 | 1322 |
| Valentine, NE | <i>P_A</i> | psia | | | | | | | | | | | | | 13.39 |
| Ely, NV | <i>T_{AN}</i> | °F | 13.1 | 16.9 | 22.9 | 27.7 | 34.4 | 42 | 49.2 | 48.1 | 38.7 | 28.9 | 19.8 | 12.6 | 29.5 |
| Ely, NV | <i>T_{AX}</i> | °F | 38.9 | 41.6 | 49.8 | 56 | 67 | 77.7 | 86.9 | 84.6 | 75.6 | 62.1 | 48.1 | 38.8 | 60.6 |
| Ely, NV | <i>V</i> | mi/hr | 9.2 | 8.9 | 9.6 | 9.8 | 9.4 | 9.6 | 9.4 | 9.6 | 9.2 | 9.2 | 8.7 | 8.9 | 9.4 |
| Ely, NV | <i>I</i> | Btu/ft ² /day | 724 | 1006 | 1454 | 1843 | 2146 | 2418 | 2371 | 2173 | 1800 | 1303 | 875 | 669 | 1565 |
| Ely, NV | <i>P_A</i> | psia | | | | | | | | | | | | | 11.72 |
| Las Vegas, NV | <i>T_{AN}</i> | °F | 39.4 | 43.2 | 49.2 | 55.6 | 65.8 | 74.3 | 81.2 | 79.8 | 71.4 | 58.7 | 46.3 | 38.7 | 58.6 |
| Las Vegas, NV | <i>T_{AX}</i> | °F | 57.6 | 61.9 | 69.8 | 77.1 | 88.2 | 97.7 | 103.7 | 101.8 | 94 | 80.2 | 66 | 56.3 | 79.5 |
| Las Vegas, NV | <i>V</i> | mi/hr | 6.5 | 7.2 | 8.7 | 10.3 | 10.1 | 10.1 | 8.9 | 8.5 | 7.8 | 7.2 | 6.5 | 6.5 | 8.3 |
| Las Vegas, NV | <i>I</i> | Btu/ft ² /day | 965 | 1244 | 1732 | 2164 | 2466 | 2628 | 2439 | 2202 | 1938 | 1479 | 1093 | 885 | 1769 |
| Las Vegas, NV | <i>P_A</i> | psia | | | | | | | | | | | | | 13.6 |
| Lovelock, NV | <i>T_{AN}</i> | °F | 20.8 | 25.3 | 29.2 | 35.2 | 44.8 | 51.9 | 58.3 | 54.6 | 45.3 | 35.2 | 24.4 | 19.3 | 37 |
| Lovelock, NV | <i>T_{AX}</i> | °F | 43.4 | 50.5 | 59.3 | 64.7 | 75.4 | 84.8 | 95.4 | 92.8 | 83.9 | 69.3 | 53.9 | 43.4 | 68.1 |
| Lovelock, NV | <i>V</i> | mi/hr | 4.9 | 6 | 7.4 | 8.3 | 8.5 | 8.3 | 7.6 | 6.9 | 6 | 5.8 | 5.1 | 4.7 | 6.7 |
| Lovelock, NV | <i>I</i> | Btu/ft ² /day | 687 | 992 | 1414 | 1822 | 2189 | 2471 | 2533 | 2252 | 1833 | 1274 | 802 | 587 | 1571 |
| Lovelock, NV | <i>P_A</i> | psia | | | | | | | | | | | | | 12.76 |
| Mercury, NV | <i>T_{AN}</i> | °F | 35.1 | 38.2 | 42.8 | 48.2 | 57.9 | 66.2 | 73.7 | 72.4 | 64 | 52 | 41.1 | 34.2 | 52.2 |
| Mercury, NV | <i>T_{AX}</i> | °F | 55.2 | 58.3 | 65.8 | 72 | 82.9 | 92.2 | 99 | 97.3 | 89.6 | 76.4 | 63.3 | 54.1 | 75.5 |
| Mercury, NV | <i>V</i> | mi/hr | 8.3 | 8.5 | 9.2 | 10.3 | 9.8 | 10.1 | 9.2 | 9.2 | 8.3 | 8.1 | 8.1 | 8.1 | 8.9 |

| | | | | | | | | | | | | | | | |
|-------------------|-----------------------|--------------------------|------|------|------|------|------|------|------|------|------|------|------|------|-------|
| Mercury, NV | <i>I</i> | Btu/ft ² /day | 937 | 1212 | 1714 | 2151 | 2464 | 2664 | 2527 | 2313 | 1977 | 1482 | 1077 | 860 | 1781 |
| Mercury, NV | <i>P_A</i> | psia | | | | | | | | | | | | | 13.16 |
| Reno, NV | <i>T_{AN}</i> | °F | 25.1 | 28.6 | 32.8 | 37 | 45.5 | 52.3 | 59.2 | 56.7 | 48.7 | 39 | 30 | 25.1 | 40 |
| Reno, NV | <i>T_{AX}</i> | °F | 45.5 | 50.3 | 57.7 | 62.3 | 72.6 | 81.9 | 91.7 | 89.7 | 81.8 | 68.5 | 54.8 | 45.2 | 66.8 |
| Reno, NV | <i>V</i> | mi/hr | 4.7 | 5.6 | 6.9 | 8.3 | 7.8 | 7.6 | 7.2 | 6.5 | 5.4 | 4.7 | 4.9 | 5.1 | 6.3 |
| Reno, NV | <i>I</i> | Btu/ft ² /day | 715 | 992 | 1471 | 1889 | 2232 | 2473 | 2512 | 2249 | 1854 | 1310 | 859 | 633 | 1599 |
| Reno, NV | <i>P_A</i> | psia | | | | | | | | | | | | | 12.53 |
| Tonopah, NV | <i>T_{AN}</i> | °F | 21.9 | 25.6 | 29.9 | 34.9 | 44.2 | 52.3 | 58.8 | 56.8 | 49.1 | 38.4 | 27.5 | 20.2 | 38.3 |
| Tonopah, NV | <i>T_{AX}</i> | °F | 44.5 | 48.3 | 56.5 | 62.7 | 73.5 | 83.5 | 91.4 | 89.2 | 80.6 | 67.6 | 53.7 | 43.8 | 66.3 |
| Tonopah, NV | <i>V</i> | mi/hr | 8.9 | 9.6 | 10.7 | 11.6 | 10.7 | 10.3 | 9.2 | 9.2 | 8.9 | 9.4 | 9.2 | 8.7 | 9.6 |
| Tonopah, NV | <i>I</i> | Btu/ft ² /day | 828 | 1128 | 1629 | 2056 | 2344 | 2586 | 2507 | 2304 | 1922 | 1430 | 997 | 779 | 1709 |
| Tonopah, NV | <i>P_A</i> | psia | | | | | | | | | | | | | 12.08 |
| Winnemucca, NV | <i>T_{AN}</i> | °F | 20.5 | 24.4 | 27.5 | 31.4 | 39.4 | 46.3 | 53.5 | 49.9 | 40.7 | 30.5 | 23.1 | 18.8 | 33.8 |
| Winnemucca, NV | <i>T_{AN}</i> | °F | 41.4 | 47 | 55.3 | 60.4 | 71.3 | 81.5 | 92.8 | 90.4 | 81.1 | 66.1 | 51.3 | 41.1 | 65 |
| Winnemucca, NV | <i>T_{AN}</i> | mi/hr | 7.2 | 7.6 | 8.1 | 8.3 | 8.3 | 8.3 | 7.6 | 7.4 | 6.9 | 6.7 | 6.7 | 7.2 | 7.6 |
| Winnemucca, NV | <i>T_{AN}</i> | Btu/ft ² /day | 652 | 964 | 1380 | 1762 | 2147 | 2437 | 2523 | 2232 | 1795 | 1248 | 760 | 555 | 1538 |
| Winnemucca, NV | <i>T_{AN}</i> | psia | | | | | | | | | | | | | 12.57 |
| Concord, NH | <i>T_{AN}</i> | °F | 12.3 | 14.6 | 23.2 | 33.2 | 43.2 | 53.8 | 58.5 | 57.1 | 48.4 | 36.8 | 29 | 18.8 | 35.7 |
| Concord, NH | <i>T_{AX}</i> | °F | 30.5 | 34 | 43 | 57 | 68.1 | 77 | 81.4 | 80.6 | 72.3 | 59.8 | 47.8 | 36.3 | 57.3 |
| Concord, NH | <i>V</i> | mi/hr | 6.7 | 7.4 | 7.4 | 7.2 | 6.3 | 5.6 | 5.1 | 4.7 | 4.9 | 5.6 | 5.6 | 6.5 | 6 |
| Concord, NH | <i>I</i> | Btu/ft ² /day | 535 | 803 | 1097 | 1469 | 1684 | 1801 | 1844 | 1644 | 1267 | 869 | 556 | 446 | 1168 |
| Concord, NH | <i>P_A</i> | psia | | | | | | | | | | | | | 14.5 |
| Atlantic City, NJ | <i>T_{AN}</i> | °F | 25.5 | 25.9 | 32.7 | 41.9 | 50.5 | 61 | 66.5 | 65 | 57.5 | 45.6 | 37.1 | 28.7 | 44.8 |
| Atlantic City, NJ | <i>T_{AX}</i> | °F | 42.4 | 44 | 51.4 | 62 | 71 | 79.9 | 84.8 | 83.4 | 76.9 | 66.2 | 55.9 | 46.1 | 63.7 |
| Atlantic City, NJ | <i>V</i> | mi/hr | 9.8 | 10.1 | 10.5 | 10.3 | 8.7 | 7.8 | 7.4 | 6.7 | 7.4 | 7.6 | 8.5 | 9.4 | 8.7 |
| Atlantic City, NJ | <i>I</i> | Btu/ft ² /day | 646 | 924 | 1224 | 1581 | 1800 | 1935 | 1927 | 1733 | 1394 | 1048 | 720 | 578 | 1292 |
| Atlantic City, NJ | <i>P_A</i> | psia | | | | | | | | | | | | | 14.66 |
| Newark, NJ | <i>T_{AN}</i> | °F | 26.3 | 27.7 | 34.8 | 44.8 | 54.1 | 64.3 | 69.5 | 68.6 | 60.9 | 49 | 40.3 | 31 | 47.6 |
| Newark, NJ | <i>T_{AX}</i> | °F | 39.6 | 42.1 | 50.5 | 62 | 72 | 81.3 | 85.7 | 84.2 | 76.7 | 65.2 | 54.6 | 43.8 | 63.1 |
| Newark, NJ | <i>V</i> | mi/hr | 11 | 11.2 | 11.2 | 10.5 | 9.6 | 9.2 | 8.9 | 8.5 | 8.9 | 9.4 | 9.8 | 10.7 | 9.8 |

| | | | | | | | | | | | | | | | |
|-----------------|-----------------------|--------------------------|------|------|------|------|------|------|------|------|------|------|------|------|-------|
| Newark, NJ | <i>I</i> | Btu/ft ² /day | 602 | 887 | 1195 | 1502 | 1748 | 1854 | 1838 | 1629 | 1324 | 975 | 638 | 521 | 1226 |
| Newark, NJ | <i>P_A</i> | psia | | | | | | | | | | | | | 14.69 |
| Albuquerque, NM | <i>T_{AN}</i> | °F | 27.6 | 31.4 | 36.4 | 43.7 | 53.8 | 62.3 | 67.1 | 65.4 | 58.6 | 46.7 | 35 | 27.5 | 46.3 |
| Albuquerque, NM | <i>T_{AX}</i> | °F | 48.1 | 53.7 | 61.2 | 69.4 | 79.8 | 88.8 | 90.5 | 87.8 | 81.4 | 69.9 | 56.6 | 47.1 | 69.5 |
| Albuquerque, NM | <i>V</i> | mi/hr | 7.2 | 7.8 | 8.7 | 9.8 | 9.4 | 8.9 | 7.8 | 7.4 | 7.4 | 7.4 | 7.2 | 6.7 | 8.1 |
| Albuquerque, NM | <i>I</i> | Btu/ft ² /day | 1003 | 1270 | 1699 | 2126 | 2356 | 2479 | 2312 | 2082 | 1846 | 1469 | 1114 | 904 | 1722 |
| Albuquerque, NM | <i>P_A</i> | psia | | | | | | | | | | | | | 12.13 |
| Gallup, NM | <i>T_{AN}</i> | °F | 14.9 | 19.5 | 22.7 | 28.4 | 37.5 | 45.1 | 54.3 | 53.3 | 43.8 | 30.9 | 19.9 | 13.8 | 32 |
| Gallup, NM | <i>T_{AX}</i> | °F | 44.1 | 48.7 | 56.4 | 64 | 74.3 | 83.9 | 87.5 | 84.3 | 78.5 | 67 | 54.2 | 44 | 65.6 |
| Gallup, NM | <i>V</i> | mi/hr | 5.4 | 6.5 | 7.8 | 9.4 | 8.7 | 8.1 | 6.7 | 5.8 | 5.8 | 6 | 5.6 | 5.1 | 6.7 |
| Gallup, NM | <i>I</i> | Btu/ft ² /day | 930 | 1194 | 1654 | 2095 | 2350 | 2507 | 2187 | 1943 | 1806 | 1466 | 1072 | 825 | 1669 |
| Gallup, NM | <i>P_A</i> | psia | | | | | | | | | | | | | 11.63 |
| Roswell, NM | <i>T_{AN}</i> | °F | 27.8 | 32.5 | 38.5 | 46.1 | 56.4 | 64.5 | 68.5 | 67 | 59.5 | 47.9 | 35.2 | 27.7 | 47.6 |
| Roswell, NM | <i>T_{AX}</i> | °F | 55.6 | 61.3 | 68.4 | 77 | 86.1 | 93.7 | 93.9 | 91.9 | 86 | 76 | 64 | 55.3 | 75.8 |
| Roswell, NM | <i>V</i> | mi/hr | 7.6 | 8.7 | 9.6 | 10.5 | 10.1 | 10.1 | 8.5 | 7.6 | 7.8 | 7.8 | 7.6 | 7.4 | 8.7 |
| Roswell, NM | <i>I</i> | Btu/ft ² /day | 1013 | 1323 | 1744 | 2125 | 2301 | 2434 | 2302 | 2085 | 1822 | 1452 | 1127 | 939 | 1722 |
| Roswell, NM | <i>P_A</i> | psia | | | | | | | | | | | | | 12.88 |
| Albany, NY | <i>T_{AN}</i> | °F | 16.1 | 18.1 | 26.4 | 37.7 | 47.7 | 57.9 | 62 | 60.9 | 52.7 | 40.8 | 32.5 | 22.4 | 39.6 |
| Albany, NY | <i>T_{AX}</i> | °F | 31 | 34.1 | 43.8 | 57.8 | 68.7 | 77.6 | 81.3 | 80 | 72 | 59.3 | 47.7 | 35.9 | 57.4 |
| Albany, NY | <i>V</i> | mi/hr | 8.5 | 8.9 | 9.4 | 9.2 | 7.8 | 6.9 | 6.7 | 5.8 | 6.3 | 7.2 | 7.8 | 8.5 | 7.8 |
| Albany, NY | <i>I</i> | Btu/ft ² /day | 532 | 789 | 1096 | 1496 | 1739 | 1853 | 1872 | 1640 | 1300 | 882 | 534 | 422 | 1180 |
| Albany, NY | <i>P_A</i> | psia | | | | | | | | | | | | | 14.55 |
| Binghamton, NY | <i>T_{AN}</i> | °F | 16.6 | 17.6 | 25.1 | 36.3 | 46.5 | 56.1 | 59.9 | 59.1 | 51.3 | 40.9 | 32 | 22 | 38.6 |
| Binghamton, NY | <i>T_{AX}</i> | °F | 29.2 | 31.7 | 40.5 | 54.1 | 65.2 | 73.6 | 77.1 | 76.2 | 68.4 | 56.4 | 44.8 | 33.5 | 54.2 |
| Binghamton, NY | <i>V</i> | mi/hr | 9.8 | 9.8 | 9.8 | 9.6 | 8.5 | 7.8 | 7.4 | 6.9 | 7.8 | 8.5 | 8.9 | 9.6 | 8.7 |
| Binghamton, NY | <i>I</i> | Btu/ft ² /day | 500 | 745 | 1056 | 1449 | 1722 | 1839 | 1818 | 1614 | 1224 | 833 | 498 | 406 | 1142 |
| Binghamton, NY | <i>P_A</i> | psia | | | | | | | | | | | | | 13.87 |
| Buffalo, NY | <i>T_{AN}</i> | °F | 19.3 | 19.7 | 26.5 | 37.2 | 47.9 | 58.4 | 62.6 | 61.7 | 54.2 | 43.7 | 34.7 | 24.9 | 40.9 |

| | | | | | | | | | | | | | | | |
|------------------------|----------|--------------------------|------|------|------|------|------|------|------|------|------|------|------|------|-------|
| Buffalo, NY | T_{AX} | °F | 31.5 | 32.9 | 41.3 | 54.7 | 66.1 | 75.3 | 78.9 | 78.1 | 71.1 | 58.7 | 47.4 | 36.1 | 56 |
| Buffalo, NY | V | mi/hr | 12.1 | 11.6 | 10.7 | 10.5 | 9.8 | 8.9 | 8.9 | 8.1 | 8.7 | 9.6 | 10.5 | 11.4 | 10.1 |
| Buffalo, NY | I | Btu/ft ² /day | 447 | 730 | 1070 | 1453 | 1793 | 1939 | 1865 | 1643 | 1273 | 808 | 478 | 382 | 1157 |
| Buffalo, NY | P_A | psia | | | | | | | | | | | | | 14.33 |
| Long Island, NY | T_{AN} | °F | 24.7 | 25.3 | 31.8 | 41.1 | 50.1 | 60.7 | 66.5 | 65.6 | 58.1 | 46.1 | 38 | 29.4 | 44.8 |
| Long Island, NY | T_{AX} | °F | 38.9 | 40.4 | 47.3 | 58 | 67.6 | 76.6 | 81.8 | 80.5 | 73.8 | 63.2 | 53.3 | 43.9 | 60.5 |
| Long Island, NY | V | mi/hr | 10.1 | 10.3 | 10.5 | 10.1 | 8.9 | 8.3 | 7.8 | 7.4 | 8.1 | 8.5 | 9.2 | 9.8 | 8.9 |
| Long Island, NY | I | Btu/ft ² /day | 591 | 878 | 1196 | 1527 | 1785 | 1896 | 1890 | 1694 | 1347 | 988 | 643 | 518 | 1246 |
| Long Island, NY | P_A | psia | | | | | | | | | | | | | 14.65 |
| Massena, NY | T_{AN} | °F | 6.6 | 8 | 19.5 | 33.8 | 44.8 | 54.8 | 59.3 | 57.2 | 48.9 | 38.2 | 28.6 | 16 | 34.6 |
| Massena, NY | T_{AX} | °F | 24.3 | 27.4 | 37.9 | 53.7 | 66.9 | 75.7 | 79.4 | 78.1 | 70.1 | 56.5 | 44.2 | 31.3 | 53.8 |
| Massena, NY | V | mi/hr | 8.7 | 8.5 | 8.7 | 8.9 | 7.8 | 6.7 | 6.5 | 5.8 | 6.3 | 7.6 | 8.3 | 8.5 | 7.6 |
| Massena, NY | I | Btu/ft ² /day | 445 | 741 | 1072 | 1452 | 1753 | 1876 | 1865 | 1646 | 1236 | 764 | 449 | 348 | 1137 |
| Massena, NY | P_A | psia | | | | | | | | | | | | | 14.58 |
| New York-LaGuardia, NY | T_{AN} | °F | 28.3 | 29.4 | 35.9 | 45.7 | 55.1 | 65.4 | 71 | 70.5 | 63.7 | 52.4 | 43.3 | 33.6 | 49.5 |
| New York-LaGuardia, NY | T_{AX} | °F | 39.6 | 41.6 | 49 | 60.5 | 70.3 | 79.8 | 84.7 | 83.2 | 75.9 | 64.7 | 54.1 | 44.1 | 62.3 |
| New York-LaGuardia, NY | V | mi/hr | 12.8 | 12.8 | 12.8 | 11.6 | 10.7 | 10.1 | 9.6 | 9.4 | 10.3 | 10.7 | 11.6 | 12.5 | 11.2 |
| New York-LaGuardia, NY | I | Btu/ft ² /day | 583 | 863 | 1154 | 1499 | 1760 | 1878 | 1859 | 1636 | 1314 | 962 | 627 | 511 | 1220 |
| New York-LaGuardia, NY | P_A | psia | | | | | | | | | | | | | 14.69 |
| New York-Kennedy, NY | T_{AN} | °F | 27.1 | 28.1 | 34.6 | 43.9 | 53 | 63.1 | 68.9 | 68.3 | 61.5 | 50.1 | 41.2 | 32 | 47.6 |
| New York-Kennedy, NY | T_{AX} | °F | 39.2 | 41 | 48.2 | 58.5 | 67.8 | 77.2 | 82.4 | 81.4 | 75 | 63.8 | 53.5 | 43.6 | 61 |
| New York-Kennedy, NY | V | mi/hr | 12.5 | 12.8 | 12.8 | 11.9 | 10.5 | 10.1 | 9.8 | 9.4 | 9.8 | 10.7 | 11.4 | 12.8 | 11.2 |
| New York-Kennedy, NY | I | Btu/ft ² /day | 588 | 861 | 1175 | 1516 | 1760 | 1898 | 1867 | 1661 | 1328 | 969 | 630 | 513 | 1231 |
| New York-Kennedy, NY | P_A | psia | | | | | | | | | | | | | 14.68 |
| Rochester, NY | T_{AN} | °F | 18.7 | 19.3 | 26.4 | 37.2 | 47 | 57.1 | 61.2 | 60.3 | 52.7 | 42.4 | 33.7 | 24.4 | 40 |
| Rochester, NY | T_{AX} | °F | 31.9 | 33.8 | 42.1 | 55.6 | 67.1 | 76.4 | 80 | 78.8 | 71.5 | 59.3 | 47.7 | 36.6 | 56.7 |
| Rochester, NY | V | mi/hr | 10.7 | 10.5 | 10.3 | 10.1 | 8.9 | 8.1 | 7.8 | 7.2 | 7.6 | 8.7 | 9.4 | 10.3 | 9.2 |

| | | | | | | | | | | | | | | | |
|--------------------|----------|--------------------------|------|------|------|------|------|------|------|------|------|------|------|------|-------|
| Rochester, NY | I | Btu/ft ² /day | 463 | 719 | 1059 | 1432 | 1759 | 1886 | 1849 | 1621 | 1242 | 788 | 480 | 385 | 1140 |
| Rochester, NY | P_A | psia | | | | | | | | | | | | | 14.37 |
| Syracuse, NY | T_{AN} | °F | 17 | 18 | 25.7 | 36.9 | 47 | 57.2 | 61.7 | 60.6 | 52.7 | 42.2 | 33.5 | 23.4 | 39.7 |
| Syracuse, NY | T_{AX} | °F | 31.3 | 33.2 | 42.1 | 56.5 | 68 | 77.1 | 80.6 | 79.7 | 72 | 59.4 | 47.9 | 36.4 | 57 |
| Syracuse, NY | V | mi/hr | 9.8 | 9.6 | 9.4 | 9.2 | 8.1 | 7.2 | 7.2 | 6.5 | 7.2 | 7.8 | 8.7 | 9.6 | 8.3 |
| Syracuse, NY | I | Btu/ft ² /day | 457 | 685 | 1033 | 1468 | 1797 | 1896 | 1884 | 1651 | 1246 | 801 | 472 | 380 | 1147 |
| Syracuse, NY | P_A | psia | | | | | | | | | | | | | 14.47 |
| Asheville, NC | T_{AN} | °F | 28.4 | 30.3 | 36.1 | 44 | 52.3 | 60.3 | 64 | 63.5 | 56.7 | 45.2 | 36 | 29.7 | 45.6 |
| Asheville, NC | T_{AX} | °F | 47.5 | 50.3 | 57.7 | 67.3 | 74 | 80 | 83 | 82.1 | 76.2 | 67.4 | 57.9 | 48.8 | 66 |
| Asheville, NC | V | mi/hr | 8.5 | 8.3 | 8.3 | 7.6 | 6 | 4.9 | 4.7 | 4.3 | 4.7 | 5.6 | 6.9 | 7.6 | 6.5 |
| Asheville, NC | I | Btu/ft ² /day | 802 | 1054 | 1361 | 1697 | 1862 | 1887 | 1872 | 1723 | 1455 | 1186 | 870 | 717 | 1374 |
| Asheville, NC | P_A | psia | | | | | | | | | | | | | 13.6 |
| Charlotte, NC | T_{AN} | °F | 33.1 | 35.2 | 41.9 | 49.7 | 58.4 | 66.7 | 70.1 | 69.3 | 62.7 | 50.9 | 41.2 | 34.3 | 51.1 |
| Charlotte, NC | T_{AX} | °F | 51.5 | 55 | 62.9 | 71.9 | 78.7 | 85.5 | 88.6 | 87.4 | 81.3 | 71.8 | 62.1 | 52.9 | 70.8 |
| Charlotte, NC | V | mi/hr | 6.5 | 6.9 | 7.6 | 7.4 | 6.7 | 5.8 | 5.6 | 5.4 | 6 | 5.4 | 5.8 | 6 | 6.3 |
| Charlotte, NC | I | Btu/ft ² /day | 785 | 1029 | 1385 | 1741 | 1918 | 1996 | 1931 | 1731 | 1475 | 1177 | 866 | 707 | 1395 |
| Charlotte, NC | P_A | psia | | | | | | | | | | | | | 14.32 |
| Raleigh-Durham, NC | T_{AN} | °F | 32.1 | 33.8 | 40.3 | 48.6 | 56.9 | 66 | 69.9 | 68.7 | 61.9 | 49.7 | 40.4 | 33.5 | 50.2 |
| Raleigh-Durham, NC | T_{AX} | °F | 51 | 54.2 | 62.4 | 71.6 | 78.5 | 85.9 | 89.1 | 87.7 | 81.2 | 71.7 | 62.3 | 52.8 | 70.7 |
| Raleigh-Durham, NC | V | mi/hr | 6.9 | 6.9 | 7.8 | 7.8 | 6.9 | 6 | 6 | 5.4 | 5.8 | 5.1 | 5.6 | 6 | 6.5 |
| Raleigh-Durham, NC | I | Btu/ft ² /day | 771 | 1029 | 1359 | 1725 | 1911 | 1969 | 1931 | 1744 | 1435 | 1155 | 853 | 699 | 1382 |
| Raleigh-Durham, NC | P_A | psia | | | | | | | | | | | | | 14.47 |
| Greensboro, NC | T_{AN} | °F | 30.9 | 32.7 | 39.7 | 48.1 | 56.7 | 65.6 | 69.3 | 68.2 | 61.1 | 49.3 | 39.8 | 32.5 | 49.5 |
| Greensboro, NC | T_{AX} | °F | 48.4 | 51.7 | 60 | 69.7 | 76.5 | 83.7 | 86.8 | 85.6 | 79 | 69.6 | 59.8 | 50.1 | 68.4 |
| Greensboro, NC | V | mi/hr | 8.1 | 8.1 | 8.7 | 8.7 | 7.6 | 6.7 | 6.3 | 5.8 | 6.3 | 6.3 | 6.7 | 6.9 | 7.2 |
| Greensboro, NC | I | Btu/ft ² /day | 758 | 1023 | 1354 | 1701 | 1875 | 1956 | 1912 | 1717 | 1418 | 1146 | 851 | 692 | 1367 |
| Greensboro, NC | P_A | psia | | | | | | | | | | | | | 14.23 |
| Wilmington, NC | T_{AN} | °F | 36.9 | 38 | 44.2 | 52.5 | 60.7 | 69.2 | 73 | 71.5 | 66.2 | 55.1 | 45.3 | 38.1 | 54.2 |

| | | | | | | | | | | | | | | | |
|----------------|----------|--------------------------|------|------|------|------|------|------|------|------|------|------|------|------|-------|
| Wilmington, NC | T_{AX} | °F | 56.3 | 58.8 | 65.5 | 73.7 | 79.7 | 85.7 | 88.7 | 87.2 | 82.6 | 74.8 | 66.7 | 58.4 | 73.2 |
| Wilmington, NC | V | mi/hr | 8.1 | 8.3 | 8.9 | 9.2 | 8.3 | 7.4 | 6.9 | 6.5 | 7.2 | 6.5 | 6.9 | 7.4 | 7.6 |
| Wilmington, NC | I | Btu/ft ² /day | 811 | 1068 | 1426 | 1808 | 1938 | 1942 | 1917 | 1722 | 1405 | 1178 | 910 | 747 | 1406 |
| Wilmington, NC | P_A | psia | | | | | | | | | | | | | 14.68 |
| Bismarck, ND | T_{AN} | °F | 2.1 | 8.4 | 19.3 | 31.3 | 43 | 52.9 | 57.8 | 56.1 | 46.1 | 33.1 | 20 | 8.4 | 31.5 |
| Bismarck, ND | T_{AX} | °F | 21.6 | 27.6 | 39.9 | 55.9 | 67.3 | 76.2 | 83.4 | 83 | 72.3 | 56.7 | 39.5 | 26.8 | 54.2 |
| Bismarck, ND | V | mi/hr | 8.9 | 9.2 | 10.1 | 10.7 | 10.7 | 9.6 | 8.7 | 8.9 | 9.2 | 9.4 | 8.9 | 9.2 | 9.4 |
| Bismarck, ND | I | Btu/ft ² /day | 411 | 666 | 1092 | 1523 | 1811 | 1994 | 2092 | 1798 | 1335 | 859 | 488 | 348 | 1201 |
| Bismarck, ND | P_A | psia | | | | | | | | | | | | | 13.85 |
| Fargo, ND | T_{AN} | °F | 0.3 | 5.7 | 19.3 | 33.5 | 45.3 | 56 | 59.6 | 57.8 | 48.6 | 36.1 | 21.6 | 7.9 | 32.6 |
| Fargo, ND | T_{AX} | °F | 16.7 | 22.7 | 35.2 | 54.3 | 67.6 | 76.3 | 80.5 | 80 | 70.8 | 55.2 | 37.1 | 22.7 | 51.6 |
| Fargo, ND | V | mi/hr | 11 | 11.4 | 12.1 | 12.3 | 12.3 | 10.3 | 9.2 | 9.6 | 10.5 | 11.4 | 11.4 | 11.2 | 11 |
| Fargo, ND | I | Btu/ft ² /day | 383 | 606 | 1023 | 1562 | 1804 | 1914 | 1984 | 1716 | 1261 | 785 | 445 | 313 | 1149 |
| Fargo, ND | P_A | psia | | | | | | | | | | | | | 14.23 |
| Minot, ND | T_{AN} | °F | 3.5 | 8.8 | 19.3 | 32.1 | 43.3 | 53.4 | 58.2 | 56.2 | 47 | 34.4 | 20.9 | 8.9 | 32.2 |
| Minot, ND | T_{AX} | °F | 19.4 | 24.9 | 36.4 | 53.9 | 65.4 | 73.7 | 80.2 | 80.5 | 70.1 | 54.4 | 36.7 | 23.9 | 51.6 |
| Minot, ND | V | mi/hr | 12.1 | 11.6 | 11.6 | 11.4 | 11.9 | 10.5 | 9.6 | 9.8 | 10.5 | 11.6 | 11.9 | 12.1 | 11.2 |
| Minot, ND | I | Btu/ft ² /day | 380 | 628 | 1069 | 1537 | 1781 | 1928 | 2042 | 1735 | 1249 | 793 | 433 | 299 | 1156 |
| Minot, ND | P_A | psia | | | | | | | | | | | | | 13.81 |
| Williston, ND | T_{AN} | °F | 0.5 | 7.4 | 18.4 | 30.9 | 40.9 | 50.6 | 56.6 | 54.9 | 43.8 | 31.3 | 18.1 | 6 | 29.9 |
| Williston, ND | T_{AX} | °F | 20.3 | 26.9 | 39.3 | 55.5 | 66 | 74.9 | 82.9 | 82.8 | 71.5 | 55.2 | 37.7 | 25 | 53.2 |
| Williston, ND | V | mi/hr | 8.3 | 8.5 | 9.2 | 10.1 | 10.3 | 9.4 | 8.3 | 8.7 | 8.7 | 8.9 | 8.5 | 8.5 | 8.9 |
| Williston, ND | I | Btu/ft ² /day | 369 | 634 | 1067 | 1545 | 1838 | 2010 | 2154 | 1817 | 1312 | 813 | 445 | 311 | 1193 |
| Williston, ND | P_A | psia | | | | | | | | | | | | | 13.72 |
| Akron, OH | T_{AN} | °F | 20.1 | 21.7 | 29 | 39.7 | 49.2 | 58.9 | 62.5 | 61.5 | 53.9 | 43 | 34.1 | 24.7 | 41.5 |
| Akron, OH | T_{AX} | °F | 33.4 | 36.1 | 46 | 59.6 | 69 | 77.8 | 81.3 | 80.1 | 72.8 | 60.8 | 48.5 | 36.9 | 58.5 |
| Akron, OH | V | mi/hr | 10.7 | 10.5 | 10.3 | 10.1 | 8.7 | 7.6 | 7.4 | 6.7 | 7.4 | 8.5 | 9.6 | 10.3 | 8.9 |
| Akron, OH | I | Btu/ft ² /day | 490 | 720 | 1075 | 1421 | 1683 | 1840 | 1859 | 1645 | 1327 | 892 | 538 | 432 | 1160 |
| Akron, OH | P_A | psia | | | | | | | | | | | | | 14.07 |
| Cleveland, OH | T_{AN} | °F | 21.6 | 23.2 | 29.8 | 40.4 | 50 | 60.1 | 64.1 | 63.2 | 55.8 | 45.3 | 36.3 | 26.4 | 43 |

| | | | | | | | | | | | | | | | |
|----------------|----------|--------------------------|------|------|------|------|------|------|------|------|------|------|------|------|-------|
| Cleveland, OH | T_{AX} | °F | 34.2 | 36.7 | 45.2 | 58.3 | 68.5 | 77.9 | 81.3 | 80 | 73.3 | 61.7 | 49.7 | 37.9 | 58.7 |
| Cleveland, OH | V | mi/hr | 11.2 | 10.5 | 10.5 | 10.3 | 9.2 | 8.3 | 8.1 | 7.6 | 8.3 | 9.4 | 10.5 | 11 | 9.6 |
| Cleveland, OH | I | Btu/ft ² /day | 462 | 689 | 1067 | 1430 | 1756 | 1944 | 1923 | 1672 | 1335 | 851 | 511 | 380 | 1168 |
| Cleveland, OH | P_A | psia | | | | | | | | | | | | | 14.29 |
| Columbus, OH | T_{AN} | °F | 23 | 25 | 32.7 | 43.1 | 52.4 | 62.3 | 65.7 | 64.6 | 56.8 | 45.2 | 36.2 | 27.2 | 44.5 |
| Columbus, OH | T_{AX} | °F | 36.5 | 39.9 | 50.3 | 63.4 | 72.5 | 81.1 | 84.1 | 83.3 | 76.7 | 64.7 | 51.9 | 40.1 | 62 |
| Columbus, OH | V | mi/hr | 9.2 | 8.9 | 8.9 | 8.9 | 7.6 | 6.7 | 6.3 | 5.8 | 6 | 6.9 | 8.1 | 8.7 | 7.6 |
| Columbus, OH | I | Btu/ft ² /day | 527 | 743 | 1080 | 1472 | 1716 | 1889 | 1866 | 1692 | 1388 | 971 | 601 | 456 | 1200 |
| Columbus, OH | P_A | psia | | | | | | | | | | | | | 14.27 |
| Dayton, OH | T_{AN} | °F | 21.1 | 23.6 | 31.6 | 42.3 | 52.2 | 61.9 | 64.9 | 63.6 | 55.4 | 44.7 | 34.9 | 25.4 | 43.5 |
| Dayton, OH | T_{AX} | °F | 34.9 | 38.7 | 49.1 | 62.1 | 71.3 | 80 | 83.2 | 82.4 | 75.9 | 63.9 | 50.7 | 38.4 | 60.9 |
| Dayton, OH | V | mi/hr | 11.4 | 11 | 11 | 11 | 9.4 | 8.3 | 7.8 | 7.2 | 7.8 | 9.2 | 10.3 | 10.7 | 9.6 |
| Dayton, OH | I | Btu/ft ² /day | 517 | 759 | 1122 | 1479 | 1747 | 1925 | 1936 | 1738 | 1409 | 993 | 607 | 456 | 1224 |
| Dayton, OH | P_A | psia | | | | | | | | | | | | | 14.17 |
| Mansfield, OH | T_{AN} | °F | 19.4 | 21.3 | 28.8 | 39.3 | 48.9 | 58.6 | 61.9 | 61 | 53.2 | 42.9 | 33.6 | 24.4 | 41.1 |
| Mansfield, OH | T_{AX} | °F | 32.8 | 35.6 | 45.4 | 59.1 | 68.9 | 77.7 | 80.8 | 79.5 | 72.9 | 61.3 | 48.1 | 37.1 | 58.3 |
| Mansfield, OH | V | mi/hr | 11.2 | 10.7 | 10.5 | 10.7 | 9.2 | 7.8 | 7.4 | 6.7 | 7.4 | 8.9 | 10.3 | 10.7 | 9.4 |
| Mansfield, OH | I | Btu/ft ² /day | 492 | 700 | 1071 | 1438 | 1709 | 1882 | 1904 | 1643 | 1329 | 918 | 553 | 423 | 1172 |
| Mansfield, OH | P_A | psia | | | | | | | | | | | | | 14.03 |
| Toledo, OH | T_{AN} | °F | 19.4 | 21.5 | 28.9 | 39.7 | 49.4 | 59.5 | 62.8 | 61.8 | 53.5 | 42.9 | 33.7 | 24.1 | 41.5 |
| Toledo, OH | T_{AX} | °F | 32.4 | 35.7 | 46.2 | 59.8 | 70.3 | 80.1 | 83.5 | 81.6 | 75.1 | 62.5 | 48.9 | 36.3 | 59.4 |
| Toledo, OH | V | mi/hr | 10.5 | 9.8 | 9.8 | 10.3 | 8.7 | 7.2 | 6.9 | 6.3 | 6.7 | 8.3 | 9.4 | 9.6 | 8.7 |
| Toledo, OH | I | Btu/ft ² /day | 485 | 754 | 1125 | 1446 | 1747 | 1939 | 1938 | 1656 | 1360 | 912 | 537 | 408 | 1192 |
| Toledo, OH | P_A | psia | | | | | | | | | | | | | 14.34 |
| Youngstown, OH | T_{AN} | °F | 20.1 | 21.3 | 28.2 | 38.8 | 47.3 | 56.6 | 60.2 | 59.2 | 52.1 | 42 | 34.3 | 24.7 | 40.4 |
| Youngstown, OH | T_{AX} | °F | 33.3 | 36 | 45.5 | 59.3 | 68.9 | 77.5 | 80.9 | 79.8 | 72.4 | 60.6 | 48.7 | 36.9 | 58.3 |
| Youngstown, OH | V | mi/hr | 10.1 | 9.6 | 9.6 | 9.6 | 8.3 | 7.2 | 6.9 | 6.5 | 7.2 | 8.1 | 9.2 | 9.6 | 8.5 |
| Youngstown, OH | I | Btu/ft ² /day | 476 | 714 | 1070 | 1410 | 1680 | 1842 | 1839 | 1631 | 1295 | 859 | 520 | 423 | 1147 |
| Youngstown, OH | P_A | psia | | | | | | | | | | | | | 14.08 |

| | | | | | | | | | | | | | | | |
|-------------------|----------|--------------------------|------|------|------|------|------|------|------|------|------|------|------|------|-------|
| Oklahoma City, OK | T_{AN} | °F | 28.7 | 32.8 | 40.5 | 49.1 | 59.3 | 67.4 | 71.5 | 70.6 | 62.5 | 51 | 39.5 | 30.9 | 50.3 |
| Oklahoma City, OK | T_{AX} | °F | 48.7 | 54.1 | 62.1 | 70.8 | 78.9 | 86.9 | 92.8 | 92.1 | 83.2 | 72.6 | 60.3 | 50.4 | 71.1 |
| Oklahoma City, OK | V | mi/hr | 11.4 | 11.9 | 13.4 | 13.4 | 11.4 | 10.7 | 9.8 | 9.2 | 9.6 | 11 | 11.6 | 11.4 | 11.2 |
| Oklahoma City, OK | I | Btu/ft ² /day | 831 | 1090 | 1389 | 1757 | 1898 | 2111 | 2215 | 1982 | 1600 | 1235 | 889 | 751 | 1479 |
| Oklahoma City, OK | P_A | psia | | | | | | | | | | | | | 14.01 |
| Tulsa, OK | T_{AN} | °F | 28.9 | 32.9 | 40.9 | 50.1 | 60.2 | 68.6 | 73.4 | 72.2 | 62.6 | 51.3 | 40.4 | 31.3 | 51.1 |
| Tulsa, OK | T_{AX} | °F | 47.4 | 53.4 | 61.7 | 71 | 78.7 | 86.5 | 92.3 | 92.4 | 83.2 | 72.6 | 60.2 | 49.6 | 70.8 |
| Tulsa, OK | V | mi/hr | 9.2 | 9.4 | 10.7 | 11.2 | 9.6 | 9.2 | 8.7 | 7.6 | 7.8 | 8.7 | 9.4 | 9.2 | 9.2 |
| Tulsa, OK | I | Btu/ft ² /day | 748 | 1023 | 1320 | 1671 | 1822 | 2027 | 2152 | 1938 | 1523 | 1166 | 816 | 682 | 1407 |
| Tulsa, OK | P_A | psia | | | | | | | | | | | | | 14.36 |
| Astoria, OR | T_{AN} | °F | 38.7 | 38.1 | 39.5 | 41.9 | 46.5 | 50.7 | 54.1 | 54.1 | 50.4 | 45.3 | 41 | 38.6 | 44.9 |
| Astoria, OR | T_{AX} | °F | 49.1 | 51.3 | 52.7 | 55.3 | 59.8 | 63.2 | 66.8 | 67.7 | 66.8 | 60 | 53.2 | 48.6 | 57.9 |
| Astoria, OR | V | mi/hr | 8.5 | 7.8 | 7.8 | 7.8 | 7.6 | 7.8 | 8.1 | 7.2 | 6.7 | 6.7 | 7.8 | 8.7 | 7.6 |
| Astoria, OR | I | Btu/ft ² /day | 343 | 600 | 877 | 1252 | 1537 | 1627 | 1708 | 1492 | 1196 | 728 | 391 | 302 | 1005 |
| Astoria, OR | P_A | psia | | | | | | | | | | | | | 14.69 |
| Burns, OR | T_{AN} | °F | 17.3 | 19.4 | 25.6 | 29.5 | 37.3 | 42.5 | 48.4 | 45.6 | 37.3 | 28.3 | 22.3 | 16 | 30.8 |
| Burns, OR | T_{AX} | °F | 35.1 | 39.3 | 49 | 55.6 | 65.8 | 74 | 86 | 84.4 | 76 | 61.2 | 45 | 34.7 | 58.8 |
| Burns, OR | V | mi/hr | 5.1 | 5.6 | 6.9 | 7.8 | 7.6 | 7.2 | 6.7 | 6.5 | 6 | 5.8 | 5.4 | 5.1 | 6.3 |
| Burns, OR | I | Btu/ft ² /day | 475 | 707 | 1195 | 1606 | 2000 | 2285 | 2459 | 2155 | 1691 | 1098 | 573 | 384 | 1386 |
| Burns, OR | P_A | psia | | | | | | | | | | | | | 12.63 |
| Eugene, OR | T_{AN} | °F | 35.6 | 36 | 38 | 40.5 | 44.7 | 48.3 | 52.7 | 52.2 | 48.4 | 42.4 | 38.6 | 35.5 | 42.7 |
| Eugene, OR | T_{AX} | °F | 47.1 | 50.9 | 55.4 | 59.6 | 66.2 | 72.1 | 82.5 | 82 | 76.7 | 63.4 | 51.8 | 45.9 | 62.8 |
| Eugene, OR | V | mi/hr | 6.9 | 6.9 | 7.2 | 6.9 | 6.5 | 6.9 | 7.4 | 7.2 | 6.7 | 6.5 | 6.7 | 7.2 | 6.9 |
| Eugene, OR | I | Btu/ft ² /day | 396 | 673 | 998 | 1386 | 1739 | 1961 | 2238 | 1960 | 1491 | 839 | 449 | 322 | 1204 |
| Eugene, OR | P_A | psia | | | | | | | | | | | | | 14.5 |
| Medford, OR | T_{AN} | °F | 33 | 34.5 | 37.2 | 40.6 | 47 | 52.1 | 58.7 | 57.5 | 50.8 | 42.2 | 36.4 | 33.1 | 43.6 |
| Medford, OR | T_{AX} | °F | 47.6 | 54.3 | 58.8 | 63.4 | 72.6 | 80 | 90.7 | 89.6 | 83.9 | 69.2 | 52.9 | 45.8 | 67.4 |
| Medford, OR | V | mi/hr | 3.4 | 4 | 4.5 | 4.7 | 5.1 | 5.4 | 5.1 | 4.7 | 3.6 | 3.1 | 2.9 | 3.4 | 4 |

| | | | | | | | | | | | | | | | |
|----------------|-----------------------|--------------------------|------|------|------|------|------|------|------|------|------|------|------|------|-------|
| Medford, OR | <i>I</i> | Btu/ft ² /day | 502 | 774 | 1143 | 1490 | 1917 | 2257 | 2415 | 2117 | 1649 | 1051 | 541 | 430 | 1357 |
| Medford, OR | <i>P_A</i> | psia | | | | | | | | | | | | | 13.69 |
| Pendleton, OR | <i>T_{AN}</i> | °F | 29.5 | 31.4 | 35.4 | 39.6 | 46.4 | 52 | 58.4 | 57.5 | 50.6 | 40.8 | 34 | 29.1 | 42.1 |
| Pendleton, OR | <i>T_{AX}</i> | °F | 41.1 | 46.2 | 54.3 | 60.8 | 69.4 | 77.1 | 87.9 | 86.2 | 77.4 | 62.6 | 48.3 | 40.1 | 62.6 |
| Pendleton, OR | <i>V</i> | mi/hr | 7.2 | 7.2 | 8.9 | 9.4 | 9.2 | 9.2 | 8.7 | 8.5 | 8.1 | 7.6 | 7.4 | 7.2 | 8.3 |
| Pendleton, OR | <i>I</i> | Btu/ft ² /day | 376 | 678 | 1117 | 1628 | 1970 | 2228 | 2372 | 2058 | 1541 | 960 | 460 | 309 | 1308 |
| Pendleton, OR | <i>P_A</i> | psia | | | | | | | | | | | | | 13.92 |
| Salem, OR | <i>T_{AN}</i> | °F | 36 | 35.9 | 38.3 | 40.9 | 46.1 | 50.3 | 54.9 | 54.3 | 50.2 | 43.7 | 39.4 | 35.7 | 43.8 |
| Salem, OR | <i>T_{AX}</i> | °F | 47.4 | 51.6 | 55.6 | 59.9 | 67.1 | 72.6 | 81.8 | 81.3 | 76.3 | 63.4 | 52.2 | 46.6 | 63 |
| Salem, OR | <i>V</i> | mi/hr | 7.2 | 6.7 | 7.2 | 6.7 | 6.3 | 6.5 | 6.3 | 5.8 | 5.4 | 5.6 | 6.9 | 7.4 | 6.5 |
| Salem, OR | <i>I</i> | Btu/ft ² /day | 370 | 638 | 951 | 1355 | 1703 | 1859 | 2099 | 1846 | 1392 | 807 | 416 | 307 | 1145 |
| Salem, OR | <i>P_A</i> | psia | | | | | | | | | | | | | 14.59 |
| Allentown, PA | <i>T_{AN}</i> | °F | 22 | 23.1 | 30.5 | 40.3 | 49.7 | 59.7 | 63.9 | 62.5 | 54.6 | 42.8 | 34.5 | 25.9 | 42.5 |
| Allentown, PA | <i>T_{AX}</i> | °F | 36.7 | 39.5 | 49 | 61.4 | 71.1 | 79.8 | 83.8 | 82.5 | 75 | 63.3 | 52.1 | 40.8 | 61.3 |
| Allentown, PA | <i>V</i> | mi/hr | 8.3 | 8.7 | 8.9 | 8.7 | 7.4 | 6.7 | 6.3 | 5.6 | 6.3 | 6.5 | 6.9 | 7.8 | 7.4 |
| Allentown, PA | <i>I</i> | Btu/ft ² /day | 568 | 845 | 1165 | 1495 | 1739 | 1841 | 1869 | 1636 | 1309 | 950 | 614 | 495 | 1210 |
| Allentown, PA | <i>P_A</i> | psia | | | | | | | | | | | | | 14.49 |
| Bradford, PA | <i>T_{AN}</i> | °F | 15.5 | 15.9 | 22.9 | 33.2 | 41.6 | 50.7 | 54.1 | 53.5 | 46.4 | 36.9 | 30 | 20 | 35.1 |
| Bradford, PA | <i>T_{AX}</i> | °F | 29.2 | 31.7 | 40.9 | 54.6 | 64.9 | 73 | 75.8 | 74.9 | 67.6 | 56.1 | 44.3 | 32.9 | 53.8 |
| Bradford, PA | <i>V</i> | mi/hr | 8.9 | 8.7 | 8.5 | 8.3 | 6.9 | 5.8 | 5.4 | 5.1 | 5.8 | 6.7 | 7.6 | 8.3 | 7.2 |
| Bradford, PA | <i>I</i> | Btu/ft ² /day | 483 | 742 | 1056 | 1439 | 1651 | 1781 | 1759 | 1563 | 1218 | 820 | 508 | 412 | 1119 |
| Bradford, PA | <i>P_A</i> | psia | | | | | | | | | | | | | 13.62 |
| Erie, PA | <i>T_{AN}</i> | °F | 22 | 22 | 28.3 | 39 | 49.1 | 59.7 | 64.2 | 63.4 | 56.5 | 46.1 | 37.3 | 27.5 | 42.9 |
| Erie, PA | <i>T_{AX}</i> | °F | 33.7 | 35 | 42.6 | 55.4 | 65.8 | 75.4 | 78.9 | 78 | 71.3 | 60.2 | 49 | 38 | 56.9 |
| Erie, PA | <i>V</i> | mi/hr | 11.9 | 10.7 | 10.5 | 10.1 | 9.2 | 8.3 | 8.1 | 7.8 | 8.9 | 9.8 | 11.2 | 11.6 | 9.8 |
| Erie, PA | <i>I</i> | Btu/ft ² /day | 367 | 647 | 994 | 1425 | 1756 | 1946 | 1921 | 1661 | 1281 | 825 | 474 | 327 | 1135 |
| Erie, PA | <i>P_A</i> | psia | | | | | | | | | | | | | 14.32 |
| Middletown, PA | <i>T_{AN}</i> | °F | 24.1 | 25.3 | 33.2 | 43.2 | 53.1 | 63.2 | 67.5 | 66.1 | 58 | 45.5 | 37.1 | 28.4 | 45.4 |
| Middletown, PA | <i>T_{AX}</i> | °F | 37.9 | 40.9 | 50.4 | 62.9 | 72.5 | 81.4 | 85.4 | 83.8 | 76 | 64.4 | 53.3 | 42.2 | 62.6 |
| Middletown, PA | <i>V</i> | mi/hr | 8.9 | 9.2 | 9.8 | 9.2 | 7.6 | 6.7 | 6.3 | 5.8 | 6.3 | 6.5 | 7.8 | 8.5 | 7.6 |

| | | | | | | | | | | | | | | | |
|------------------|-----------------------|--------------------------|------|------|------|------|------|------|------|------|------|------|------|------|-------|
| Middletown, PA | <i>I</i> | Btu/ft ² /day | 580 | 840 | 1164 | 1497 | 1754 | 1889 | 1852 | 1639 | 1304 | 967 | 630 | 512 | 1219 |
| Middletown, PA | <i>P_A</i> | psia | | | | | | | | | | | | | 14.53 |
| Philadelphia, PA | <i>T_{AN}</i> | °F | 27.4 | 28.3 | 35.5 | 45.4 | 54.8 | 64.9 | 70.2 | 69 | 61.6 | 49.6 | 40.5 | 31.5 | 48.2 |
| Philadelphia, PA | <i>T_{AX}</i> | °F | 40.7 | 43.2 | 52.1 | 63.9 | 73.3 | 82.3 | 86.5 | 85 | 77.7 | 66.1 | 55.3 | 44.5 | 64.2 |
| Philadelphia, PA | <i>V</i> | mi/hr | 10.3 | 10.5 | 11 | 10.3 | 8.9 | 8.7 | 8.5 | 8.1 | 8.5 | 8.7 | 9.2 | 10.1 | 9.4 |
| Philadelphia, PA | <i>I</i> | Btu/ft ² /day | 611 | 911 | 1190 | 1537 | 1778 | 1917 | 1891 | 1698 | 1357 | 1015 | 678 | 549 | 1261 |
| Philadelphia, PA | <i>P_A</i> | psia | | | | | | | | | | | | | 14.69 |
| Pittsburgh, PA | <i>T_{AN}</i> | °F | 22.2 | 23.5 | 30.8 | 41.3 | 50.2 | 59.6 | 63.5 | 62.5 | 54.8 | 43.4 | 35.3 | 26.2 | 42.8 |
| Pittsburgh, PA | <i>T_{AX}</i> | °F | 36.2 | 38.9 | 48.7 | 62 | 70.6 | 78.9 | 81.9 | 81.2 | 73.9 | 62.4 | 50.7 | 39.5 | 60.4 |
| Pittsburgh, PA | <i>V</i> | mi/hr | 9.4 | 9.2 | 9.4 | 9.2 | 7.6 | 6.9 | 6.5 | 6 | 6.3 | 6.9 | 8.1 | 8.7 | 7.8 |
| Pittsburgh, PA | <i>I</i> | Btu/ft ² /day | 520 | 760 | 1080 | 1440 | 1691 | 1846 | 1823 | 1636 | 1306 | 919 | 566 | 459 | 1170 |
| Pittsburgh, PA | <i>P_A</i> | psia | | | | | | | | | | | | | 14.1 |
| Scranton, PA | <i>T_{AN}</i> | °F | 20.3 | 21.5 | 28.7 | 39.2 | 48.6 | 57.8 | 61.7 | 60.7 | 53.2 | 42.2 | 34.5 | 25 | 41.1 |
| Scranton, PA | <i>T_{AX}</i> | °F | 33.8 | 36.5 | 45.8 | 59.1 | 69.5 | 77.6 | 81.6 | 80.2 | 72.4 | 60.4 | 49.2 | 37.7 | 58.6 |
| Scranton, PA | <i>V</i> | mi/hr | 7.6 | 8.1 | 8.1 | 7.8 | 6.9 | 6 | 6 | 5.6 | 6 | 6.3 | 6.9 | 7.4 | 6.9 |
| Scranton, PA | <i>I</i> | Btu/ft ² /day | 538 | 789 | 1115 | 1455 | 1710 | 1843 | 1852 | 1616 | 1261 | 888 | 548 | 455 | 1173 |
| Scranton, PA | <i>P_A</i> | psia | | | | | | | | | | | | | 14.21 |
| Williamsport, PA | <i>T_{AN}</i> | °F | 20.8 | 21.8 | 29.5 | 39.5 | 48.5 | 58.6 | 62.3 | 61.3 | 53.7 | 42 | 34 | 25 | 41.4 |
| Williamsport, PA | <i>T_{AX}</i> | °F | 34.9 | 37.9 | 47.9 | 61.3 | 71.4 | 79.8 | 83.5 | 82 | 73.8 | 62.1 | 50.2 | 38.6 | 60.3 |
| Williamsport, PA | <i>V</i> | mi/hr | 7.6 | 7.8 | 7.8 | 7.6 | 6.5 | 5.6 | 5.4 | 4.7 | 5.1 | 5.6 | 6.5 | 7.2 | 6.5 |
| Williamsport, PA | <i>I</i> | Btu/ft ² /day | 550 | 803 | 1122 | 1457 | 1714 | 1846 | 1830 | 1603 | 1233 | 884 | 545 | 449 | 1170 |
| Williamsport, PA | <i>P_A</i> | psia | | | | | | | | | | | | | 14.42 |
| Providence, RI | <i>T_{AN}</i> | °F | 22.5 | 24 | 30.7 | 40.2 | 49.2 | 59.3 | 64.9 | 64 | 56.6 | 44.9 | 36.8 | 27.6 | 43.4 |
| Providence, RI | <i>T_{AX}</i> | °F | 37.4 | 39.5 | 47 | 58.1 | 67.7 | 76.9 | 82.2 | 80.9 | 73.5 | 62.5 | 52.4 | 42.2 | 60 |
| Providence, RI | <i>V</i> | mi/hr | 9.6 | 10.1 | 10.5 | 10.3 | 9.4 | 8.7 | 8.5 | 8.1 | 8.1 | 8.5 | 8.7 | 9.4 | 9.2 |
| Providence, RI | <i>I</i> | Btu/ft ² /day | 579 | 859 | 1150 | 1477 | 1738 | 1847 | 1840 | 1640 | 1301 | 937 | 604 | 501 | 1206 |
| Providence, RI | <i>P_A</i> | psia | | | | | | | | | | | | | 14.66 |
| Charleston, SC | <i>T_{AN}</i> | °F | 39.6 | 41.6 | 47.8 | 54.8 | 63.2 | 70.7 | 74 | 73.3 | 68.3 | 57.7 | 48 | 41.1 | 56.7 |
| Charleston, SC | <i>T_{AX}</i> | °F | 59.2 | 62.1 | 68.9 | 75.8 | 82.3 | 87.3 | 90.2 | 88.7 | 84.1 | 76.5 | 68.6 | 60.9 | 75.4 |
| Charleston, SC | <i>V</i> | mi/hr | 8.3 | 8.5 | 9.2 | 9.2 | 8.3 | 7.6 | 7.2 | 6.7 | 7.4 | 7.2 | 7.2 | 7.6 | 7.8 |

| | | | | | | | | | | | | | | | |
|----------------|----------|--------------------------|------|------|------|------|------|------|------|------|------|------|------|------|-------|
| Charleston, SC | I | Btu/ft ² /day | 852 | 1111 | 1471 | 1856 | 1992 | 1943 | 1951 | 1723 | 1438 | 1210 | 972 | 797 | 1443 |
| Charleston, SC | P_A | psia | | | | | | | | | | | | | 14.68 |
| Columbia, SC | T_{AN} | °F | 35.3 | 37.4 | 43.9 | 51.7 | 60.7 | 68.8 | 72.2 | 71.5 | 65.2 | 52.7 | 42.4 | 35.7 | 53.1 |
| Columbia, SC | T_{AX} | °F | 56.2 | 59.6 | 67.4 | 75.7 | 82.9 | 88.6 | 91.6 | 90 | 84.5 | 75.3 | 66.1 | 57.4 | 74.6 |
| Columbia, SC | V | mi/hr | 6.7 | 6.7 | 7.4 | 7.4 | 6.7 | 6 | 5.6 | 5.1 | 5.6 | 5.1 | 5.1 | 5.8 | 6 |
| Columbia, SC | I | Btu/ft ² /day | 824 | 1073 | 1415 | 1781 | 1944 | 1975 | 1949 | 1756 | 1497 | 1206 | 923 | 761 | 1425 |
| Columbia, SC | P_A | psia | | | | | | | | | | | | | 14.58 |
| Greer, SC | T_{AN} | °F | 33.5 | 35.5 | 41.9 | 49.5 | 58.1 | 66.1 | 69.8 | 69.2 | 62.5 | 51.1 | 41.6 | 34.7 | 51.1 |
| Greer, SC | T_{AX} | °F | 51.7 | 55.2 | 62.9 | 71.7 | 78.6 | 85.4 | 88.8 | 87.3 | 81.1 | 71.4 | 61.9 | 52.8 | 70.7 |
| Greer, SC | V | mi/hr | 7.4 | 7.6 | 8.3 | 7.8 | 6.9 | 6 | 5.8 | 5.4 | 5.8 | 5.8 | 6.3 | 6.7 | 6.7 |
| Greer, SC | I | Btu/ft ² /day | 812 | 1057 | 1401 | 1767 | 1936 | 1988 | 1945 | 1780 | 1493 | 1196 | 888 | 741 | 1417 |
| Greer, SC | P_A | psia | | | | | | | | | | | | | 14.2 |
| Aberdeen, SD | T_{AN} | °F | 2.2 | 8.2 | 20.4 | 32.9 | 45.2 | 55.7 | 60.1 | 57.3 | 47.2 | 34.4 | 20.4 | 8.5 | 32.7 |
| Aberdeen, SD | T_{AX} | °F | 21.1 | 27.6 | 39.7 | 56.2 | 68.3 | 77.2 | 82.2 | 81 | 72.4 | 57.6 | 40.1 | 26.5 | 54.1 |
| Aberdeen, SD | V | mi/hr | 10.1 | 10.5 | 11.2 | 12.1 | 12.1 | 10.3 | 8.7 | 8.7 | 10.1 | 10.3 | 10.3 | 10.3 | 10.5 |
| Aberdeen, SD | I | Btu/ft ² /day | 435 | 703 | 1115 | 1559 | 1815 | 1996 | 2073 | 1799 | 1358 | 880 | 520 | 372 | 1219 |
| Aberdeen, SD | P_A | psia | | | | | | | | | | | | | 14.01 |
| Huron, SD | T_{AN} | °F | 6.7 | 12 | 22.6 | 34.6 | 46.5 | 57 | 61.9 | 59.9 | 49.7 | 36.3 | 23.1 | 11.9 | 35.2 |
| Huron, SD | T_{AX} | °F | 25 | 31.3 | 42.9 | 57.8 | 69.2 | 78.4 | 84.6 | 83.1 | 74.4 | 59.9 | 42.6 | 29.3 | 56.5 |
| Huron, SD | V | mi/hr | 10.5 | 10.7 | 11.4 | 11.9 | 11.4 | 9.8 | 9.2 | 9.2 | 10.1 | 10.3 | 10.5 | 10.5 | 10.5 |
| Huron, SD | I | Btu/ft ² /day | 483 | 770 | 1131 | 1556 | 1845 | 2014 | 2094 | 1817 | 1404 | 919 | 562 | 403 | 1250 |
| Huron, SD | P_A | psia | | | | | | | | | | | | | 14.03 |
| Pierre, SD | T_{AN} | °F | 10 | 14.7 | 23.7 | 34.8 | 45.9 | 56 | 62.1 | 60.4 | 50.5 | 37.2 | 24.6 | 14.6 | 36.2 |
| Pierre, SD | T_{AX} | °F | 28.7 | 34.7 | 45.4 | 58.9 | 69.5 | 79.2 | 87.7 | 86.7 | 77.2 | 60.6 | 44.6 | 32.6 | 58.8 |
| Pierre, SD | V | mi/hr | 10.7 | 10.7 | 11.9 | 12.1 | 11.9 | 10.5 | 10.3 | 10.3 | 10.7 | 11 | 10.5 | 11 | 11 |
| Pierre, SD | I | Btu/ft ² /day | 506 | 772 | 1135 | 1521 | 1857 | 2054 | 2099 | 1853 | 1428 | 927 | 553 | 421 | 1261 |
| Pierre, SD | P_A | psia | | | | | | | | | | | | | 13.81 |
| Rapid City, SD | T_{AN} | °F | 13.6 | 16.6 | 23.8 | 32.7 | 43 | 52.3 | 59.1 | 57.6 | 47.4 | 35.4 | 23.4 | 15.5 | 35 |
| Rapid City, SD | T_{AX} | °F | 35.5 | 39 | 47.3 | 56.5 | 66.6 | 76.4 | 85.9 | 85.7 | 75.5 | 60.6 | 46.4 | 37.2 | 59.4 |
| Rapid City, SD | V | mi/hr | 9.8 | 10.7 | 11.4 | 12.1 | 11.6 | 10.1 | 9.4 | 9.4 | 9.8 | 10.7 | 10.3 | 9.8 | 10.5 |

| | | | | | | | | | | | | | | | |
|-----------------|-----------------------|--------------------------|------|------|------|------|------|------|------|------|------|------|------|------|-------|
| Rapid City, SD | <i>I</i> | Btu/ft ² /day | 599 | 844 | 1212 | 1588 | 1906 | 2092 | 2150 | 1920 | 1505 | 1016 | 619 | 503 | 1329 |
| Rapid City, SD | <i>P_A</i> | psia | | | | | | | | | | | | | 13.11 |
| Sioux Falls, SD | <i>T_{AN}</i> | °F | 7.9 | 13.1 | 23.5 | 35.4 | 47.2 | 57.9 | 62.5 | 60.6 | 50.6 | 37.8 | 24.2 | 12.7 | 36.1 |
| Sioux Falls, SD | <i>T_{AX}</i> | °F | 25.2 | 31.2 | 42.5 | 57.5 | 68.9 | 78.4 | 82.9 | 81 | 73.2 | 59.6 | 42.7 | 29.4 | 56 |
| Sioux Falls, SD | <i>V</i> | mi/hr | 10.1 | 10.3 | 11.2 | 11.9 | 11.2 | 9.8 | 9.2 | 8.7 | 9.6 | 9.8 | 10.1 | 9.8 | 10.1 |
| Sioux Falls, SD | <i>I</i> | Btu/ft ² /day | 507 | 777 | 1169 | 1523 | 1751 | 1979 | 2046 | 1762 | 1393 | 947 | 576 | 442 | 1239 |
| Sioux Falls, SD | <i>P_A</i> | psia | | | | | | | | | | | | | 13.95 |
| Bristol, TN | <i>T_{AN}</i> | °F | 27.2 | 29.5 | 35.5 | 44 | 52.5 | 61.2 | 64.9 | 63.7 | 56.4 | 44.7 | 35.6 | 28.9 | 45.3 |
| Bristol, TN | <i>T_{AX}</i> | °F | 45.5 | 49.2 | 58 | 67.9 | 75.5 | 82.1 | 84.6 | 84.5 | 78.8 | 68.8 | 57.7 | 47.9 | 66.7 |
| Bristol, TN | <i>V</i> | mi/hr | 5.4 | 5.6 | 6 | 5.6 | 4.7 | 3.8 | 3.6 | 2.9 | 3.1 | 3.6 | 4 | 4.7 | 4.5 |
| Bristol, TN | <i>I</i> | Btu/ft ² /day | 682 | 901 | 1249 | 1616 | 1853 | 1928 | 1885 | 1780 | 1483 | 1128 | 790 | 611 | 1325 |
| Bristol, TN | <i>P_A</i> | psia | | | | | | | | | | | | | 13.92 |
| Chattanooga, TN | <i>T_{AN}</i> | °F | 32.7 | 34.8 | 41.6 | 49.7 | 58.5 | 66.8 | 70.6 | 70 | 63 | 50.8 | 40.5 | 34.2 | 51.1 |
| Chattanooga, TN | <i>T_{AX}</i> | °F | 50.4 | 54.3 | 63 | 72.5 | 79.4 | 86.1 | 89.2 | 89 | 83 | 72.8 | 61.4 | 51.9 | 71.1 |
| Chattanooga, TN | <i>V</i> | mi/hr | 5.8 | 6 | 6.5 | 6 | 4.9 | 4.3 | 4.3 | 3.8 | 4 | 4 | 4.5 | 5.4 | 4.9 |
| Chattanooga, TN | <i>I</i> | Btu/ft ² /day | 722 | 965 | 1295 | 1662 | 1859 | 1950 | 1915 | 1796 | 1471 | 1170 | 824 | 654 | 1357 |
| Chattanooga, TN | <i>P_A</i> | psia | | | | | | | | | | | | | 14.34 |
| Knoxville, TN | <i>T_{AN}</i> | °F | 30.8 | 33.3 | 40 | 48.7 | 57.3 | 65.6 | 69.2 | 68.3 | 61.4 | 49.2 | 39.3 | 32.4 | 49.6 |
| Knoxville, TN | <i>T_{AX}</i> | °F | 47.3 | 51.4 | 60.2 | 69.8 | 77.5 | 84.2 | 87.2 | 87 | 81.1 | 70.4 | 59.1 | 49.1 | 68.7 |
| Knoxville, TN | <i>V</i> | mi/hr | 6.5 | 6.7 | 7.2 | 6.9 | 6.3 | 5.4 | 5.4 | 4.5 | 4.7 | 4.7 | 5.4 | 6 | 5.8 |
| Knoxville, TN | <i>I</i> | Btu/ft ² /day | 692 | 933 | 1270 | 1656 | 1877 | 1970 | 1925 | 1808 | 1484 | 1160 | 798 | 625 | 1350 |
| Knoxville, TN | <i>P_A</i> | psia | | | | | | | | | | | | | 14.18 |
| Memphis, TN | <i>T_{AN}</i> | °F | 34 | 37.1 | 44.7 | 53.9 | 63.1 | 70.9 | 74.1 | 73.2 | 65.8 | 54.6 | 43.9 | 36.2 | 54.3 |
| Memphis, TN | <i>T_{AX}</i> | °F | 49.7 | 54.3 | 62.9 | 72.4 | 80.7 | 88.1 | 90.8 | 90.7 | 84.6 | 74 | 61.6 | 51.7 | 71.8 |
| Memphis, TN | <i>V</i> | mi/hr | 9.2 | 9.2 | 9.8 | 9.6 | 8.5 | 7.4 | 6.9 | 6.7 | 7.2 | 7.2 | 8.1 | 8.7 | 8.3 |
| Memphis, TN | <i>I</i> | Btu/ft ² /day | 696 | 939 | 1275 | 1661 | 1860 | 2008 | 1967 | 1832 | 1508 | 1165 | 794 | 626 | 1361 |
| Memphis, TN | <i>P_A</i> | psia | | | | | | | | | | | | | 14.55 |
| Nashville, TN | <i>T_{AN}</i> | °F | 30.5 | 32.9 | 40.2 | 49.3 | 58.5 | 66.7 | 70.8 | 69.8 | 62.1 | 50.3 | 40.2 | 32.8 | 50.3 |
| Nashville, TN | <i>T_{AX}</i> | °F | 47.2 | 51.5 | 60.5 | 70.4 | 77.9 | 85.2 | 88.6 | 88.6 | 82.2 | 71.4 | 59.5 | 49.5 | 69.4 |
| Nashville, TN | <i>V</i> | mi/hr | 8.1 | 8.1 | 8.3 | 8.1 | 6.7 | 6 | 5.8 | 5.6 | 5.8 | 6.3 | 7.2 | 7.6 | 6.9 |

| | | | | | | | | | | | | | | | |
|-----------------------|----------|--------------------------|------|------|------|------|------|------|------|------|------|------|------|------|-------|
| Nashville, TN | I | Btu/ft ² /day | 654 | 896 | 1261 | 1614 | 1798 | 1955 | 1886 | 1778 | 1467 | 1128 | 772 | 583 | 1316 |
| Nashville, TN | P_A | psia | | | | | | | | | | | | | 14.39 |
| Abilene, TX | T_{AN} | °F | 34.2 | 37.8 | 44.9 | 52.6 | 62.1 | 69.1 | 72.6 | 72 | 64.4 | 54.6 | 43.4 | 35.2 | 53.6 |
| Abilene, TX | T_{AX} | °F | 56.5 | 60.6 | 68 | 76.6 | 83.9 | 89.9 | 93.6 | 92.8 | 85.9 | 76.8 | 65.4 | 57.4 | 75.6 |
| Abilene, TX | V | mi/hr | 11 | 11.4 | 12.5 | 13.2 | 11.9 | 11.2 | 10.1 | 8.7 | 8.9 | 10.3 | 10.7 | 10.7 | 11 |
| Abilene, TX | I | Btu/ft ² /day | 959 | 1205 | 1557 | 1936 | 2052 | 2245 | 2252 | 2006 | 1701 | 1375 | 1046 | 902 | 1603 |
| Abilene, TX | P_A | psia | | | | | | | | | | | | | 13.79 |
| Amarillo, TX | T_{AN} | °F | 24.9 | 28 | 34.1 | 42.4 | 52.8 | 61.7 | 65.8 | 64.8 | 56.9 | 45.3 | 33.2 | 25.8 | 44.7 |
| Amarillo, TX | T_{AX} | °F | 50.1 | 54.4 | 61.9 | 70 | 78.9 | 87.1 | 90.5 | 88.3 | 81.8 | 71.3 | 59 | 50.1 | 70.3 |
| Amarillo, TX | V | mi/hr | 12.1 | 12.5 | 13.9 | 14.8 | 13.6 | 13.9 | 12.3 | 11.6 | 12.1 | 12.5 | 12.5 | 12.1 | 12.8 |
| Amarillo, TX | I | Btu/ft ² /day | 882 | 1232 | 1607 | 1972 | 2156 | 2357 | 2313 | 2021 | 1748 | 1388 | 1057 | 877 | 1634 |
| Amarillo, TX | P_A | psia | | | | | | | | | | | | | 12.95 |
| Austin, TX | T_{AN} | °F | 40.3 | 43.9 | 49.9 | 57.5 | 66.3 | 71.9 | 73.8 | 73.5 | 68.2 | 58.8 | 48.3 | 41 | 57.8 |
| Austin, TX | T_{AX} | °F | 61.6 | 65.3 | 71.6 | 78.9 | 85.9 | 91.5 | 94.4 | 95.5 | 89.8 | 81.4 | 70.5 | 63.1 | 79.1 |
| Austin, TX | V | mi/hr | 8.3 | 8.7 | 9.2 | 8.9 | 8.5 | 8.1 | 7.4 | 6.5 | 6.3 | 6.9 | 7.6 | 7.8 | 7.8 |
| Austin, TX | I | Btu/ft ² /day | 868 | 1085 | 1368 | 1699 | 1812 | 2094 | 2135 | 2023 | 1645 | 1313 | 956 | 806 | 1484 |
| Austin, TX | P_A | psia | | | | | | | | | | | | | 14.33 |
| Brownsville, TX | T_{AN} | °F | 52.8 | 56 | 60.7 | 66.6 | 72.7 | 76.4 | 76.9 | 76.8 | 73.6 | 67.6 | 59.9 | 53.5 | 66.1 |
| Brownsville, TX | T_{AX} | °F | 70.6 | 73.7 | 78.1 | 82.8 | 88 | 91.6 | 92.8 | 93.5 | 89.6 | 84.7 | 78 | 71.6 | 82.9 |
| Brownsville, TX | V | mi/hr | 10.1 | 11.2 | 11.9 | 12.5 | 12.1 | 11 | 11 | 9.2 | 7.4 | 8.7 | 9.2 | 9.6 | 10.3 |
| Brownsville, TX | I | Btu/ft ² /day | 899 | 1152 | 1425 | 1673 | 1913 | 2051 | 2061 | 1951 | 1616 | 1386 | 1040 | 846 | 1501 |
| Brownsville, TX | P_A | psia | | | | | | | | | | | | | 14.68 |
| Corpus Christi, TX | T_{AN} | °F | 48.4 | 51.9 | 57.3 | 63.9 | 70.6 | 74.5 | 75.3 | 75.5 | 72.5 | 65.3 | 56.2 | 49.6 | 63.4 |
| Corpus Christi, TX | T_{AX} | °F | 66.9 | 70.6 | 75.5 | 81.1 | 86.2 | 90.4 | 92.4 | 93.8 | 89.3 | 83.7 | 75.1 | 68.5 | 81.1 |
| Corpus Christi, TX | V | mi/hr | 12.1 | 12.5 | 13.4 | 14.1 | 12.5 | 10.5 | 10.7 | 9.8 | 9.2 | 10.7 | 11.4 | 11.6 | 11.6 |
| Corpus Christi, TX | I | Btu/ft ² /day | 891 | 1113 | 1385 | 1636 | 1850 | 2072 | 2110 | 1975 | 1662 | 1397 | 1040 | 838 | 1497 |
| Corpus Christi, TX | P_A | psia | | | | | | | | | | | | | 14.68 |
| Dallas-Fort Worth, TX | T_{AN} | °F | 37 | 40.8 | 47.8 | 55.8 | 65.4 | 72.6 | 76.3 | 76.1 | 68.6 | 57.8 | 47.1 | 38.8 | 57 |

| | | | | | | | | | | | | | | | |
|-----------------------|----------|--------------------------|------|------|------|------|------|------|------|------|------|------|------|------|-------|
| Dallas-Fort Worth, TX | T_{AX} | °F | 56.2 | 60.7 | 67.8 | 75.7 | 83.4 | 91 | 95.3 | 95.3 | 87.8 | 78 | 66.2 | 57.7 | 76.3 |
| Dallas-Fort Worth, TX | V | mi/hr | 10.5 | 10.7 | 11.9 | 12.1 | 11 | 10.5 | 9.8 | 8.5 | 8.3 | 9.4 | 10.3 | 10.3 | 10.3 |
| Dallas-Fort Worth, TX | I | Btu/ft ² /day | 837 | 1089 | 1388 | 1744 | 1860 | 2087 | 2171 | 1981 | 1623 | 1263 | 933 | 795 | 1481 |
| Dallas-Fort Worth, TX | P_A | psia | | | | | | | | | | | | | 14.4 |
| El Paso, TX | T_{AN} | °F | 34.6 | 38.8 | 44.3 | 52.2 | 62.3 | 69.8 | 72.2 | 70.6 | 64.5 | 53.3 | 40.8 | 33.9 | 53.1 |
| El Paso, TX | T_{AX} | °F | 58.2 | 63.2 | 70.3 | 78.7 | 88.2 | 95.4 | 94.4 | 92.4 | 87.4 | 78.3 | 66.1 | 57.3 | 77.5 |
| El Paso, TX | V | mi/hr | 7.8 | 8.9 | 10.1 | 11 | 10.1 | 9.2 | 8.1 | 7.4 | 7.4 | 7.6 | 7.4 | 7.4 | 8.5 |
| El Paso, TX | I | Btu/ft ² /day | 1125 | 1406 | 1856 | 2259 | 2494 | 2537 | 2276 | 2106 | 1895 | 1574 | 1244 | 1048 | 1818 |
| El Paso, TX | P_A | psia | | | | | | | | | | | | | 12.76 |
| Houston, TX | T_{AN} | °F | 43.8 | 47 | 52.7 | 59.6 | 67.9 | 73.4 | 75.1 | 74.7 | 69.9 | 61 | 51.2 | 44.9 | 60.1 |
| Houston, TX | T_{AX} | °F | 62.6 | 66.4 | 72.3 | 78.7 | 85.9 | 90.7 | 93.1 | 93.4 | 88.9 | 81.2 | 71.2 | 64.1 | 79 |
| Houston, TX | V | mi/hr | 7.8 | 8.3 | 8.5 | 8.9 | 8.1 | 6.7 | 5.8 | 5.6 | 6 | 6.7 | 7.2 | 7.6 | 7.4 |
| Houston, TX | I | Btu/ft ² /day | 832 | 1022 | 1333 | 1635 | 1828 | 1915 | 1930 | 1804 | 1567 | 1288 | 930 | 767 | 1404 |
| Houston, TX | P_A | psia | | | | | | | | | | | | | 14.65 |
| Lubbock, TX | T_{AN} | °F | 28 | 31.6 | 38.2 | 46.8 | 57.3 | 65.4 | 69 | 67.5 | 59.6 | 48.6 | 36.6 | 28.5 | 48.1 |
| Lubbock, TX | T_{AX} | °F | 54 | 58.8 | 66.1 | 74.7 | 83.3 | 90.3 | 92.3 | 90.6 | 84 | 74.8 | 62.7 | 54.6 | 73.9 |
| Lubbock, TX | V | mi/hr | 11.6 | 12.3 | 13.9 | 14.3 | 13.6 | 13 | 11 | 9.8 | 10.1 | 11 | 11.4 | 11.4 | 11.9 |
| Lubbock, TX | I | Btu/ft ² /day | 968 | 1252 | 1627 | 2008 | 2166 | 2352 | 2283 | 2060 | 1728 | 1406 | 1081 | 904 | 1653 |
| Lubbock, TX | P_A | psia | | | | | | | | | | | | | 13.07 |
| Lufkin, TX | T_{AN} | °F | 39.3 | 42.4 | 48.6 | 55.6 | 64.7 | 70.7 | 72.8 | 72.1 | 66.8 | 56.5 | 46.8 | 40.3 | 56.4 |
| Lufkin, TX | T_{AX} | °F | 59.8 | 64 | 70.5 | 77.5 | 84.6 | 90 | 93.1 | 93.6 | 88.3 | 79.5 | 68.8 | 61.1 | 77.6 |
| Lufkin, TX | V | mi/hr | 6.9 | 7.4 | 7.6 | 7.6 | 6.9 | 5.8 | 5.4 | 4.9 | 5.4 | 5.8 | 6.3 | 6.5 | 6.5 |
| Lufkin, TX | I | Btu/ft ² /day | 796 | 1027 | 1342 | 1686 | 1856 | 1988 | 2043 | 1915 | 1590 | 1275 | 913 | 747 | 1432 |
| Lufkin, TX | P_A | psia | | | | | | | | | | | | | 14.55 |
| Midland, TX | T_{AN} | °F | 31.8 | 35.9 | 42.1 | 50.1 | 60.9 | 68.5 | 71 | 69.7 | 62.7 | 52.4 | 39.8 | 32.1 | 51.4 |
| Midland, TX | T_{AX} | °F | 57.4 | 62.2 | 69.4 | 78.4 | 87.1 | 93 | 93.8 | 92.4 | 86 | 77.5 | 65.6 | 58.1 | 76.7 |
| Midland, TX | V | mi/hr | 10.1 | 11 | 12.1 | 12.8 | 12.3 | 12.3 | 10.7 | 9.6 | 9.6 | 10.3 | 9.8 | 9.8 | 11 |
| Midland, TX | I | Btu/ft ² /day | 1015 | 1294 | 1695 | 2089 | 2226 | 2365 | 2272 | 2073 | 1776 | 1458 | 1140 | 973 | 1698 |

| | | | | | | | | | | | | | | | |
|-----------------|----------|--------------------------|------|------|------|------|------|------|------|------|------|------|------|------|-------|
| Midland, TX | P_A | psia | | | | | | | | | | | | | 13.26 |
| Port Arthur, TX | T_{AN} | °F | 44.6 | 47.7 | 53.2 | 60.1 | 68 | 73.5 | 75 | 74.7 | 70.6 | 61.5 | 51.7 | 45.7 | 60.5 |
| Port Arthur, TX | T_{AX} | °F | 61.9 | 65.3 | 71.2 | 77.3 | 84.3 | 89.1 | 91 | 91.5 | 87.8 | 80.2 | 70.5 | 63.4 | 77.8 |
| Port Arthur, TX | V | mi/hr | 9.6 | 10.1 | 10.3 | 10.3 | 9.2 | 7.6 | 6 | 5.8 | 7.2 | 8.1 | 8.5 | 9.2 | 8.5 |
| Port Arthur, TX | I | Btu/ft ² /day | 824 | 1017 | 1355 | 1646 | 1868 | 1931 | 1918 | 1801 | 1552 | 1300 | 955 | 773 | 1412 |
| Port Arthur, TX | P_A | psia | | | | | | | | | | | | | 14.68 |
| San Angelo, TX | T_{AN} | °F | 34.4 | 38 | 45.2 | 52.8 | 62.8 | 69.6 | 72.1 | 71.3 | 64 | 53.8 | 42.7 | 35.1 | 53.5 |
| San Angelo, TX | T_{AX} | °F | 59.5 | 63.7 | 70.7 | 79.5 | 87.4 | 92.4 | 95.1 | 94 | 87.4 | 78.6 | 67.4 | 60.5 | 78 |
| San Angelo, TX | V | mi/hr | 9.6 | 10.1 | 10.7 | 11.4 | 10.5 | 10.1 | 9.2 | 8.1 | 7.8 | 8.5 | 9.2 | 9.4 | 9.6 |
| San Angelo, TX | I | Btu/ft ² /day | 968 | 1229 | 1591 | 1961 | 2072 | 2236 | 2220 | 2021 | 1711 | 1382 | 1090 | 921 | 1617 |
| San Angelo, TX | P_A | psia | | | | | | | | | | | | | 13.71 |
| San Antonio, TX | T_{AN} | °F | 42 | 45.8 | 51.8 | 59.1 | 67.6 | 73.2 | 75.2 | 75.3 | 69.8 | 60.8 | 50.5 | 43.1 | 59.5 |
| San Antonio, TX | T_{AX} | °F | 62.9 | 67.2 | 73.1 | 79.9 | 86.6 | 91.9 | 94 | 95 | 89.5 | 81.6 | 71.3 | 64.3 | 79.8 |
| San Antonio, TX | V | mi/hr | 7.6 | 7.8 | 8.9 | 9.4 | 9.4 | 9.2 | 8.5 | 7.8 | 6.9 | 7.4 | 7.6 | 7.4 | 8.1 |
| San Antonio, TX | I | Btu/ft ² /day | 893 | 1083 | 1377 | 1682 | 1821 | 2059 | 2081 | 1961 | 1640 | 1323 | 985 | 825 | 1477 |
| San Antonio, TX | P_A | psia | | | | | | | | | | | | | 14.27 |
| Victoria, TX | T_{AN} | °F | 44.5 | 48 | 53.7 | 60.5 | 68.3 | 73.3 | 74.8 | 74.4 | 70.1 | 61.6 | 51.9 | 45.5 | 60.5 |
| Victoria, TX | T_{AX} | °F | 64.6 | 68.2 | 73.5 | 79.6 | 86.1 | 91 | 93.1 | 94 | 89.5 | 82.7 | 73.1 | 66.1 | 80.1 |
| Victoria, TX | V | mi/hr | 9.8 | 10.1 | 10.5 | 11 | 10.3 | 9.2 | 8.3 | 7.4 | 7.4 | 8.3 | 8.7 | 9.2 | 9.2 |
| Victoria, TX | I | Btu/ft ² /day | 849 | 1038 | 1328 | 1597 | 1823 | 2009 | 2029 | 1887 | 1596 | 1328 | 989 | 801 | 1439 |
| Victoria, TX | P_A | psia | | | | | | | | | | | | | 14.63 |
| Waco, TX | T_{AN} | °F | 37.6 | 41.3 | 48.1 | 55.7 | 64.7 | 71.7 | 75 | 74.4 | 67.3 | 57.2 | 46.9 | 39 | 56.6 |
| Waco, TX | T_{AX} | °F | 58.4 | 62.4 | 69.2 | 77.1 | 84.7 | 91.5 | 95.8 | 96 | 89.4 | 79.8 | 68 | 59.7 | 77.7 |
| Waco, TX | V | mi/hr | 9.8 | 10.1 | 11 | 11.2 | 10.1 | 9.6 | 9.6 | 8.5 | 7.8 | 8.7 | 9.4 | 9.4 | 9.6 |
| Waco, TX | I | Btu/ft ² /day | 864 | 1081 | 1387 | 1732 | 1890 | 2135 | 2198 | 2022 | 1674 | 1302 | 958 | 823 | 1505 |
| Waco, TX | P_A | psia | | | | | | | | | | | | | 14.43 |
| Cedar City, UT | T_{AN} | °F | 19.2 | 23.3 | 28.3 | 33.5 | 42.2 | 50.9 | 59 | 57.7 | 47.7 | 36 | 25 | 18.7 | 36.8 |
| Cedar City, UT | T_{AX} | °F | 41.9 | 46 | 54.6 | 61.1 | 72.3 | 82.5 | 89.5 | 87.2 | 79.3 | 65.7 | 51.7 | 41.5 | 64.4 |
| Cedar City, UT | V | mi/hr | 6.3 | 6.7 | 8.1 | 8.9 | 8.7 | 8.7 | 7.6 | 7.6 | 7.2 | 6.7 | 6.3 | 6.3 | 7.4 |
| Cedar City, UT | I | Btu/ft ² /day | 818 | 1072 | 1548 | 1969 | 2299 | 2534 | 2285 | 2082 | 1827 | 1355 | 944 | 741 | 1623 |

| | | | | | | | | | | | | | | | |
|--------------------|----------|--------------------------|------|------|------|------|------|------|------|------|------|------|------|------|-------|
| Cedar City, UT | P_A | psia | | | | | | | | | | | | | 12.01 |
| Salt Lake City, UT | T_{AN} | °F | 23.3 | 26.9 | 34.4 | 40.2 | 49 | 57.3 | 66.4 | 64.9 | 54.3 | 42.2 | 31.1 | 24.1 | 42.9 |
| Salt Lake City, UT | T_{AX} | °F | 37.7 | 43.1 | 53.4 | 60.3 | 71.5 | 81.8 | 92.4 | 90.1 | 78.9 | 64 | 48.7 | 38 | 63.3 |
| Salt Lake City, UT | V | mi/hr | 6.7 | 7.2 | 8.7 | 9.6 | 8.9 | 9.2 | 8.9 | 9.6 | 8.7 | 8.1 | 7.4 | 7.2 | 8.3 |
| Salt Lake City, UT | I | Btu/ft ² /day | 596 | 877 | 1348 | 1685 | 2071 | 2336 | 2338 | 2052 | 1689 | 1144 | 700 | 469 | 1442 |
| Salt Lake City, UT | P_A | psia | | | | | | | | | | | | | 12.62 |
| Burlington, VT | T_{AN} | °F | 11.6 | 13.1 | 22.7 | 35.1 | 46.1 | 56.4 | 61 | 59.2 | 51.5 | 40.2 | 31.6 | 19.8 | 37.4 |
| Burlington, VT | T_{AX} | °F | 27 | 29.8 | 39.6 | 54.1 | 66.8 | 76.2 | 79.9 | 78.6 | 70.3 | 56.6 | 45.1 | 33.2 | 54.8 |
| Burlington, VT | V | mi/hr | 8.9 | 8.5 | 8.5 | 8.7 | 8.1 | 7.4 | 6.9 | 6.9 | 7.6 | 8.1 | 8.7 | 8.9 | 8.1 |
| Burlington, VT | I | Btu/ft ² /day | 474 | 733 | 1046 | 1449 | 1720 | 1874 | 1835 | 1642 | 1239 | 770 | 464 | 377 | 1135 |
| Burlington, VT | P_A | psia | | | | | | | | | | | | | 14.52 |
| DC-Dulles, VA | T_{AN} | °F | 25.8 | 26.7 | 33.9 | 43.4 | 52.3 | 61.9 | 66.5 | 65.4 | 57.6 | 44.8 | 36.2 | 28.2 | 45.2 |
| DC-Dulles, VA | T_{AX} | °F | 42.4 | 45.2 | 54.4 | 66.3 | 74 | 82.5 | 86.4 | 85.9 | 78.3 | 67 | 56.2 | 45.2 | 65.3 |
| DC-Dulles, VA | V | mi/hr | 7.8 | 8.1 | 8.5 | 8.1 | 6.7 | 6 | 5.8 | 5.6 | 6 | 6 | 6.7 | 7.2 | 6.9 |
| DC-Dulles, VA | I | Btu/ft ² /day | 653 | 939 | 1233 | 1567 | 1771 | 1900 | 1862 | 1684 | 1376 | 1062 | 711 | 590 | 1279 |
| DC-Dulles, VA | P_A | psia | | | | | | | | | | | | | 14.55 |
| DC-Reagan, VA | T_{AN} | °F | 30 | 31.2 | 38.3 | 47.9 | 57 | 66.7 | 71.5 | 70.4 | 63.2 | 51.2 | 41.7 | 33.3 | 50.2 |
| DC-Reagan, VA | T_{AX} | °F | 43.6 | 46.3 | 55.2 | 66.3 | 74.6 | 83.3 | 87.6 | 86.3 | 79 | 67.6 | 57 | 46.5 | 66.1 |
| DC-Reagan, VA | V | mi/hr | 9.6 | 9.6 | 10.5 | 9.8 | 8.9 | 8.5 | 8.1 | 7.8 | 8.3 | 8.1 | 8.7 | 8.9 | 8.9 |
| DC-Reagan, VA | I | Btu/ft ² /day | 653 | 934 | 1246 | 1578 | 1767 | 1903 | 1864 | 1712 | 1371 | 1045 | 718 | 587 | 1282 |
| DC-Reagan, VA | P_A | psia | | | | | | | | | | | | | 14.69 |
| Lynchburg, VA | T_{AN} | °F | 27.6 | 29.1 | 35.9 | 44.7 | 53 | 61.9 | 65.8 | 64.7 | 57.5 | 45.5 | 36.5 | 29.1 | 46 |
| Lynchburg, VA | T_{AX} | °F | 45.5 | 48.3 | 57.2 | 67.9 | 74.6 | 82.2 | 85.6 | 84.7 | 77.9 | 67.9 | 57.7 | 47.4 | 66.4 |
| Lynchburg, VA | V | mi/hr | 6 | 6 | 6.7 | 6.5 | 5.6 | 4.7 | 4.3 | 3.8 | 4.3 | 4.3 | 4.9 | 5.1 | 5.1 |
| Lynchburg, VA | I | Btu/ft ² /day | 740 | 1006 | 1334 | 1655 | 1855 | 2001 | 1913 | 1758 | 1439 | 1128 | 807 | 662 | 1358 |
| Lynchburg, VA | P_A | psia | | | | | | | | | | | | | 14.2 |
| Norfolk, VA | T_{AN} | °F | 34.5 | 35.2 | 41.6 | 50.2 | 58.7 | 68.1 | 72.7 | 71.6 | 66.4 | 54.8 | 45.1 | 37.2 | 53 |
| Norfolk, VA | T_{AX} | °F | 49.3 | 50.9 | 58.3 | 68.1 | 75.1 | 83.1 | 87.2 | 85.2 | 79.3 | 70 | 60.6 | 52.1 | 68.3 |
| Norfolk, VA | V | mi/hr | 9.8 | 10.1 | 10.5 | 10.7 | 9.8 | 8.7 | 8.3 | 7.8 | 9.2 | 8.7 | 8.9 | 9.2 | 9.2 |
| Norfolk, VA | I | Btu/ft ² /day | 723 | 962 | 1312 | 1674 | 1872 | 1989 | 1940 | 1743 | 1406 | 1101 | 807 | 655 | 1349 |

| | | | | | | | | | | | | | | | |
|----------------|----------|--------------------------|------|------|------|------|------|------|------|------|------|------|------|------|-------|
| Norfolk, VA | P_A | psia | | | | | | | | | | | | | 14.68 |
| Richmond, VA | T_{AN} | °F | 30.2 | 31 | 38 | 47.2 | 55.8 | 65.2 | 69.5 | 68.3 | 61.2 | 49.2 | 40.2 | 32.3 | 49 |
| Richmond, VA | T_{AX} | °F | 47.5 | 50.5 | 59 | 69.7 | 76.6 | 84.7 | 88.5 | 86.9 | 80.3 | 70.2 | 60.2 | 50.1 | 68.7 |
| Richmond, VA | V | mi/hr | 8.3 | 8.5 | 9.2 | 8.9 | 7.8 | 7.2 | 6.7 | 6.3 | 6.9 | 6.7 | 7.4 | 7.6 | 7.6 |
| Richmond, VA | I | Btu/ft ² /day | 723 | 993 | 1305 | 1650 | 1856 | 1986 | 1890 | 1735 | 1415 | 1099 | 798 | 649 | 1341 |
| Richmond, VA | P_A | psia | | | | | | | | | | | | | 14.61 |
| Roanoke, VA | T_{AN} | °F | 29.4 | 31 | 37.9 | 46.7 | 54.7 | 63.4 | 67.2 | 66.2 | 58.8 | 47.7 | 38.7 | 31.3 | 47.8 |
| Roanoke, VA | T_{AX} | °F | 45.8 | 48.7 | 57.3 | 67.8 | 75 | 82.3 | 85.9 | 85.1 | 78 | 68.4 | 57.7 | 47.4 | 66.6 |
| Roanoke, VA | V | mi/hr | 8.1 | 8.1 | 8.3 | 7.8 | 6.5 | 5.8 | 5.6 | 4.9 | 5.1 | 5.6 | 6.5 | 7.4 | 6.7 |
| Roanoke, VA | I | Btu/ft ² /day | 729 | 986 | 1293 | 1611 | 1795 | 1892 | 1860 | 1699 | 1395 | 1104 | 781 | 646 | 1316 |
| Roanoke, VA | P_A | psia | | | | | | | | | | | | | 14.1 |
| Olympia, WA | T_{AN} | °F | 33.8 | 32.9 | 35.3 | 38 | 43.4 | 47.8 | 51.3 | 50.9 | 46.4 | 40.9 | 36.6 | 33.4 | 40.9 |
| Olympia, WA | T_{AX} | °F | 45.7 | 49.3 | 53.2 | 58 | 64.9 | 69.7 | 76.7 | 76.6 | 71.5 | 59.7 | 50.2 | 44.5 | 60 |
| Olympia, WA | V | mi/hr | 6 | 5.6 | 6.3 | 6.3 | 6 | 6 | 5.4 | 4.9 | 4.7 | 5.1 | 6 | 6 | 5.6 |
| Olympia, WA | I | Btu/ft ² /day | 319 | 562 | 866 | 1257 | 1574 | 1721 | 1876 | 1624 | 1257 | 676 | 352 | 264 | 1029 |
| Olympia, WA | P_A | psia | | | | | | | | | | | | | 14.58 |
| Quillayute, WA | T_{AN} | °F | 36.4 | 35.6 | 37 | 39.1 | 43.5 | 47.9 | 51.2 | 51 | 47.5 | 42.4 | 38.6 | 35.7 | 42.2 |
| Quillayute, WA | T_{AX} | °F | 47.1 | 49.5 | 50.8 | 54.2 | 59.1 | 62.7 | 66.9 | 67.6 | 65.8 | 57.9 | 50.7 | 46.5 | 56.6 |
| Quillayute, WA | V | mi/hr | 6.5 | 6 | 6.3 | 5.8 | 5.4 | 4.9 | 4.7 | 4.5 | 4 | 4.9 | 6 | 6.3 | 5.4 |
| Quillayute, WA | I | Btu/ft ² /day | 304 | 556 | 831 | 1225 | 1520 | 1600 | 1681 | 1469 | 1170 | 653 | 351 | 257 | 968 |
| Quillayute, WA | P_A | psia | | | | | | | | | | | | | 14.59 |
| Seattle, WA | T_{AN} | °F | 37.6 | 37.8 | 39.7 | 42.8 | 48 | 52.4 | 56.4 | 56.5 | 52.9 | 46.5 | 40.5 | 36.8 | 45.7 |
| Seattle, WA | T_{AX} | °F | 46.4 | 49.4 | 52.4 | 57.2 | 63.7 | 68.5 | 75.1 | 74.8 | 69.5 | 58.6 | 50.3 | 45.4 | 59.3 |
| Seattle, WA | V | mi/hr | 8.5 | 8.3 | 8.5 | 7.8 | 7.6 | 7.6 | 7.2 | 6.9 | 6.7 | 7.2 | 8.1 | 8.7 | 7.8 |
| Seattle, WA | I | Btu/ft ² /day | 316 | 595 | 882 | 1329 | 1678 | 1842 | 1951 | 1679 | 1235 | 671 | 356 | 267 | 1067 |
| Seattle, WA | P_A | psia | | | | | | | | | | | | | 14.47 |
| Spokane, WA | T_{AN} | °F | 24.3 | 26.4 | 30.9 | 36.4 | 43.8 | 49.9 | 56.7 | 55.7 | 47.7 | 37.3 | 29.3 | 23.7 | 38.5 |
| Spokane, WA | T_{AX} | °F | 34.1 | 39.7 | 48.1 | 56 | 65.8 | 72.5 | 83.2 | 82.2 | 72.8 | 57.2 | 41.5 | 33 | 57.2 |
| Spokane, WA | V | mi/hr | 8.3 | 8.3 | 9.6 | 9.6 | 9.4 | 9.2 | 8.5 | 8.1 | 7.8 | 8.1 | 8.3 | 8.3 | 8.7 |
| Spokane, WA | I | Btu/ft ² /day | 345 | 650 | 1060 | 1497 | 1893 | 2071 | 2274 | 1947 | 1430 | 841 | 401 | 283 | 1224 |

| | | | | | | | | | | | | | | | |
|-------------------|----------|--------------------------|------|------|------|------|------|------|------|------|------|------|------|------|-------|
| Spokane, WA | P_A | psia | | | | | | | | | | | | | 13.4 |
| Stampede Pass, WA | T_{AN} | °F | 24 | 25.7 | 28.6 | 31.8 | 37.8 | 42.4 | 49 | 49.3 | 45.5 | 36.7 | 29.2 | 23.5 | 35.3 |
| Stampede Pass, WA | T_{AX} | °F | 30.7 | 33.8 | 37.9 | 43.1 | 51 | 56.6 | 65.7 | 65.7 | 60 | 47.3 | 36.2 | 30.1 | 46.5 |
| Stampede Pass, WA | V | mi/hr | 7.4 | 7.4 | 6.9 | 6.7 | 6.9 | 7.4 | 7.4 | 6.9 | 6.7 | 6.7 | 6.9 | 7.4 | 7.2 |
| Stampede Pass, WA | I | Btu/ft ² /day | 345 | 595 | 857 | 1281 | 1599 | 1703 | 1946 | 1676 | 1218 | 678 | 366 | 286 | 1046 |
| Stampede Pass, WA | P_A | psia | | | | | | | | | | | | | 12.73 |
| Yakima, WA | T_{AN} | °F | 24.1 | 27.1 | 30.8 | 35.5 | 43.5 | 49.6 | 55.1 | 53 | 45 | 35.2 | 27.5 | 23.4 | 37.5 |
| Yakima, WA | T_{AX} | °F | 38.1 | 46 | 55.3 | 62.6 | 71.8 | 78.6 | 87.9 | 86.2 | 77.9 | 63 | 47.3 | 36.6 | 62.6 |
| Yakima, WA | V | mi/hr | 4.3 | 5.4 | 6.7 | 7.4 | 7.4 | 7.6 | 7.2 | 6.7 | 6.3 | 5.6 | 4.7 | 4 | 6 |
| Yakima, WA | I | Btu/ft ² /day | 399 | 740 | 1187 | 1639 | 1987 | 2252 | 2374 | 2033 | 1537 | 937 | 483 | 315 | 1324 |
| Yakima, WA | P_A | psia | | | | | | | | | | | | | 14.14 |
| Beckley, WV | T_{AN} | °F | 24.2 | 26.2 | 32.9 | 42.7 | 50.3 | 58.6 | 62 | 61.1 | 54.2 | 43.8 | 35.2 | 27 | 43.2 |
| Beckley, WV | T_{AX} | °F | 39.5 | 42.2 | 50.7 | 62.6 | 69.3 | 76 | 78.7 | 78.4 | 72.3 | 62.8 | 51.9 | 41.6 | 60.5 |
| Beckley, WV | V | mi/hr | 8.3 | 8.1 | 8.1 | 7.8 | 6.7 | 5.6 | 5.1 | 4.9 | 5.6 | 6.3 | 6.9 | 7.6 | 6.7 |
| Beckley, WV | I | Btu/ft ² /day | 632 | 847 | 1144 | 1499 | 1680 | 1797 | 1752 | 1643 | 1346 | 1018 | 691 | 538 | 1216 |
| Beckley, WV | P_A | psia | | | | | | | | | | | | | 13.42 |
| Charleston, WV | T_{AN} | °F | 26.8 | 28.6 | 35.1 | 44.9 | 52.6 | 61.6 | 65.2 | 64.3 | 56.6 | 45 | 36.4 | 29.2 | 45.5 |
| Charleston, WV | T_{AX} | °F | 43.1 | 46.3 | 55.5 | 68.1 | 74.5 | 81.6 | 84.4 | 83.9 | 77.7 | 67.6 | 56.3 | 45.5 | 65.4 |
| Charleston, WV | V | mi/hr | 5.4 | 5.1 | 5.1 | 5.1 | 4 | 3.4 | 3.1 | 2.7 | 2.9 | 3.1 | 4 | 4.7 | 4 |
| Charleston, WV | I | Btu/ft ² /day | 579 | 814 | 1126 | 1524 | 1737 | 1916 | 1843 | 1721 | 1378 | 1024 | 667 | 512 | 1237 |
| Charleston, WV | P_A | psia | | | | | | | | | | | | | 14.16 |
| Elkins, WV | T_{AN} | °F | 20.6 | 21.5 | 28.1 | 37 | 45.9 | 55.1 | 58.9 | 58.3 | 50.7 | 38.1 | 30.3 | 22.9 | 39 |
| Elkins, WV | T_{AX} | °F | 39.7 | 42.3 | 51.2 | 63.3 | 70.5 | 77.7 | 80.5 | 80.3 | 73.9 | 64 | 52.7 | 42.2 | 61.5 |
| Elkins, WV | V | mi/hr | 5.8 | 5.8 | 5.8 | 5.8 | 4.5 | 3.6 | 3.1 | 2.7 | 2.9 | 3.6 | 4.7 | 5.1 | 4.5 |
| Elkins, WV | I | Btu/ft ² /day | 574 | 794 | 1113 | 1461 | 1619 | 1793 | 1738 | 1611 | 1293 | 972 | 618 | 498 | 1173 |
| Elkins, WV | P_A | psia | | | | | | | | | | | | | 13.69 |
| Huntington, WV | T_{AN} | °F | 26.7 | 28.9 | 35.9 | 45.8 | 53.7 | 62.5 | 66.1 | 65 | 57.1 | 45.7 | 37.2 | 29.4 | 46.2 |
| Huntington, WV | T_{AX} | °F | 42.4 | 45.9 | 55.5 | 67.7 | 74.7 | 82 | 85 | 84.7 | 78.2 | 67.6 | 55.7 | 44.9 | 65.3 |

| | | | | | | | | | | | | | | | |
|----------------|-----------------------|--------------------------|------|------|------|------|------|------|------|------|------|------|------|------|-------|
| Huntington, WV | <i>V</i> | mi/hr | 6.9 | 6.7 | 6.9 | 6.7 | 5.6 | 4.9 | 4.7 | 4.3 | 4.5 | 4.9 | 5.8 | 6.3 | 5.6 |
| Huntington, WV | <i>I</i> | Btu/ft ² /day | 570 | 828 | 1163 | 1545 | 1751 | 1915 | 1856 | 1725 | 1404 | 1045 | 676 | 519 | 1250 |
| Huntington, WV | <i>P_A</i> | psia | | | | | | | | | | | | | 14.26 |
| Eau Claire, WI | <i>T_{AN}</i> | °F | 6.6 | 11.2 | 22 | 34.8 | 46.1 | 56.4 | 60.5 | 58.9 | 49.8 | 38.1 | 25.7 | 12.8 | 35.2 |
| Eau Claire, WI | <i>T_{AX}</i> | °F | 22.7 | 28.6 | 40.7 | 56.9 | 68.6 | 77.6 | 81.4 | 79.6 | 71.2 | 57.7 | 41.2 | 27.9 | 54.5 |
| Eau Claire, WI | <i>V</i> | mi/hr | 7.4 | 7.6 | 7.6 | 8.7 | 8.3 | 7.2 | 6.5 | 6.3 | 6.9 | 7.6 | 7.6 | 7.2 | 7.4 |
| Eau Claire, WI | <i>I</i> | Btu/ft ² /day | 485 | 734 | 1116 | 1485 | 1716 | 1866 | 1895 | 1616 | 1234 | 802 | 484 | 377 | 1151 |
| Eau Claire, WI | <i>P_A</i> | psia | | | | | | | | | | | | | 14.23 |
| Green Bay, WI | <i>T_{AN}</i> | °F | 10.7 | 14 | 23.7 | 35.1 | 45.5 | 55.9 | 59.2 | 58 | 49.6 | 39.1 | 28.4 | 16.9 | 36.3 |
| Green Bay, WI | <i>T_{AX}</i> | °F | 24.9 | 29.1 | 39.9 | 54.3 | 66.2 | 75.7 | 79.6 | 78.1 | 70.8 | 57.5 | 43.1 | 30.3 | 54.1 |
| Green Bay, WI | <i>V</i> | mi/hr | 9.6 | 9.4 | 9.4 | 10.5 | 9.2 | 7.6 | 7.2 | 6.7 | 7.6 | 8.7 | 9.2 | 8.9 | 8.7 |
| Green Bay, WI | <i>I</i> | Btu/ft ² /day | 426 | 678 | 1103 | 1501 | 1748 | 1923 | 1900 | 1624 | 1274 | 820 | 504 | 373 | 1156 |
| Green Bay, WI | <i>P_A</i> | psia | | | | | | | | | | | | | 14.33 |
| La Crosse, WI | <i>T_{AN}</i> | °F | 9.9 | 15 | 25.7 | 38.7 | 49.5 | 59.6 | 63.6 | 61.9 | 53.2 | 41.6 | 29.3 | 16.5 | 38.7 |
| La Crosse, WI | <i>T_{AX}</i> | °F | 25.6 | 31.4 | 43.7 | 58.7 | 70.1 | 79.5 | 83.2 | 81 | 73.2 | 60 | 43.8 | 30.4 | 56.7 |
| La Crosse, WI | <i>V</i> | mi/hr | 8.7 | 8.9 | 9.2 | 9.8 | 9.2 | 8.1 | 7.6 | 7.4 | 8.3 | 9.2 | 9.4 | 8.7 | 8.7 |
| La Crosse, WI | <i>I</i> | Btu/ft ² /day | 507 | 767 | 1131 | 1445 | 1723 | 1887 | 1895 | 1615 | 1260 | 829 | 512 | 397 | 1164 |
| La Crosse, WI | <i>P_A</i> | psia | | | | | | | | | | | | | 14.36 |
| Madison, WI | <i>T_{AN}</i> | °F | 12.1 | 16.2 | 25.4 | 36.7 | 47.3 | 57.6 | 61.5 | 59.8 | 51 | 40.1 | 29.3 | 17.6 | 37.9 |
| Madison, WI | <i>T_{AX}</i> | °F | 26.7 | 31.6 | 43.3 | 57 | 68.3 | 77.8 | 81 | 79.2 | 72.1 | 59.4 | 44.5 | 31.4 | 56 |
| Madison, WI | <i>V</i> | mi/hr | 8.5 | 8.5 | 8.9 | 9.6 | 8.3 | 6.9 | 6.5 | 6 | 6.7 | 7.8 | 8.5 | 8.1 | 7.8 |
| Madison, WI | <i>I</i> | Btu/ft ² /day | 441 | 718 | 1122 | 1478 | 1735 | 1931 | 1911 | 1634 | 1324 | 871 | 541 | 422 | 1177 |
| Madison, WI | <i>P_A</i> | psia | | | | | | | | | | | | | 14.24 |
| Milwaukee, WI | <i>T_{AN}</i> | °F | 16.9 | 20.6 | 28.5 | 38.1 | 47.7 | 58.5 | 64.2 | 64.1 | 55.9 | 44.6 | 33 | 21.9 | 41.2 |
| Milwaukee, WI | <i>T_{AX}</i> | °F | 29.5 | 33.1 | 42.5 | 53.6 | 64.5 | 75 | 79.6 | 78.4 | 71.5 | 59.6 | 46.1 | 33.8 | 55.6 |
| Milwaukee, WI | <i>V</i> | mi/hr | 11 | 10.7 | 10.7 | 11.6 | 10.3 | 8.7 | 8.9 | 8.5 | 8.9 | 10.1 | 10.5 | 10.5 | 10.1 |
| Milwaukee, WI | <i>I</i> | Btu/ft ² /day | 477 | 755 | 1096 | 1444 | 1729 | 1926 | 1894 | 1612 | 1322 | 873 | 536 | 411 | 1173 |
| Milwaukee, WI | <i>P_A</i> | psia | | | | | | | | | | | | | 14.34 |
| Casper, WY | <i>T_{AN}</i> | °F | 16.2 | 18.1 | 23.7 | 30 | 38.7 | 46.7 | 54.4 | 53.3 | 43.4 | 32.7 | 23.8 | 16.4 | 33.1 |
| Casper, WY | <i>T_{AX}</i> | °F | 35.1 | 38.5 | 47.8 | 55.6 | 66.5 | 77.7 | 87.6 | 85.6 | 74.2 | 59 | 44.7 | 35.1 | 58.9 |

| | | | | | | | | | | | | | | | |
|------------------|-----------------|--------------------------|------|------|------|------|------|------|------|------|------|------|------|------|-------|
| Casper, WY | V | mi/hr | 14.8 | 13.4 | 12.5 | 11.6 | 10.5 | 10.3 | 9.2 | 9.4 | 9.8 | 11 | 13.4 | 15 | 11.6 |
| Casper, WY | I | Btu/ft ² /day | 601 | 877 | 1259 | 1631 | 1980 | 2243 | 2292 | 1988 | 1552 | 1046 | 650 | 505 | 1385 |
| Casper, WY | P _A | psia | | | | | | | | | | | | | 12.13 |
| Cheyenne, WY | T _{AN} | °F | 18.8 | 19.8 | 25.1 | 31.3 | 40.7 | 49.2 | 56.1 | 54.6 | 45.4 | 34.4 | 25.1 | 19.1 | 35 |
| Cheyenne, WY | T _{AX} | °F | 38.8 | 40.4 | 47.3 | 53.7 | 63.9 | 74.3 | 82.6 | 80.2 | 71.3 | 58 | 45.8 | 38.6 | 57.9 |
| Cheyenne, WY | V | mi/hr | 14.1 | 13.6 | 13.6 | 13.2 | 12.1 | 11 | 9.8 | 9.8 | 10.5 | 11.9 | 13.2 | 13.9 | 12.3 |
| Cheyenne, WY | I | Btu/ft ² /day | 712 | 975 | 1360 | 1668 | 1919 | 2196 | 2163 | 1883 | 1588 | 1131 | 761 | 609 | 1414 |
| Cheyenne, WY | P _A | psia | | | | | | | | | | | | | 11.78 |
| Lander, WY | T _{AN} | °F | 12.5 | 16.2 | 24.9 | 32.5 | 41.6 | 49.6 | 57.5 | 56.1 | 46.4 | 34.2 | 21.8 | 13.2 | 33.9 |
| Lander, WY | T _{AX} | °F | 32 | 36.2 | 46.9 | 55.1 | 65.7 | 76 | 86.2 | 84.3 | 73 | 57.8 | 42.6 | 32.3 | 57.3 |
| Lander, WY | V | mi/hr | 4.9 | 4.9 | 6.7 | 7.4 | 7.4 | 7.4 | 7.2 | 6.9 | 6.5 | 5.6 | 5.1 | 4.9 | 6.3 |
| Lander, WY | I | Btu/ft ² /day | 640 | 920 | 1320 | 1658 | 2026 | 2242 | 2256 | 1966 | 1564 | 1086 | 696 | 551 | 1411 |
| Lander, WY | P _A | psia | | | | | | | | | | | | | 12.02 |
| Rock Springs, WY | T _{AN} | °F | 13.6 | 15.5 | 23.8 | 29.7 | 38.6 | 46.8 | 55 | 53.3 | 43.6 | 33.2 | 22.1 | 14.2 | 32.5 |
| Rock Springs, WY | T _{AX} | °F | 29.2 | 32.3 | 42.8 | 51.9 | 62.7 | 73 | 82.9 | 80.2 | 69.4 | 55.5 | 39.9 | 29.6 | 54.1 |
| Rock Springs, WY | V | mi/hr | 12.1 | 11.2 | 12.1 | 12.3 | 11.2 | 10.7 | 9.4 | 8.9 | 9.4 | 11 | 11.2 | 11.4 | 11 |
| Rock Springs, WY | I | Btu/ft ² /day | 654 | 928 | 1342 | 1738 | 2044 | 2307 | 2301 | 2019 | 1673 | 1186 | 716 | 564 | 1456 |
| Rock Springs, WY | P _A | psia | | | | | | | | | | | | | 13.05 |
| Sheridan, WY | T _{AN} | °F | 13 | 16.8 | 23.4 | 31.4 | 39.8 | 47.9 | 54.8 | 53.2 | 43.5 | 32.5 | 21.5 | 13.6 | 32.6 |
| Sheridan, WY | T _{AX} | °F | 34.4 | 38.5 | 47.5 | 55.7 | 65.4 | 74.8 | 85.9 | 85.2 | 74 | 58.8 | 45.5 | 35.4 | 58.4 |
| Sheridan, WY | V | mi/hr | 6.5 | 6.9 | 7.8 | 8.9 | 8.3 | 7.2 | 6.5 | 6 | 6.3 | 6.7 | 6.5 | 6.5 | 6.9 |
| Sheridan, WY | I | Btu/ft ² /day | 482 | 767 | 1145 | 1509 | 1850 | 2030 | 2152 | 1860 | 1419 | 909 | 569 | 429 | 1260 |
| Sheridan, WY | P _A | psia | | | | | | | | | | | | | 12.73 |

^a Reference 14. Data for this table are 20-year averages for the years 1991 through 2010, prepared by the National Renewable Energy Laboratory and compiled in the National Solar Radiation Database. Only Class I sites are summarized in this table, but similar meteorological data for several hundred Class II sites may be obtained from this reference. Similar historical averages of meteorological data from nearby National Weather Service sites or site-specific data may also be used. *NOTE: The current table reflects the average minimum and maximum ambient temperatures.*

T_{AX} = average maximum ambient temperature (°F)

T_{AN} = average minimum ambient temperature (°F)

V = average wind speed (miles/hour)

I = average daily total insolation factor (Btu/ft²/day)

P_A = average atmospheric pressure (psia)

Table 7.1-8. Rim-Seal Loss Factors, K_{Ra} , K_{Rb} , and n For Floating Roof Tanks ^a

| Tank Construction And Rim-Seal System | Average-Fitting Seals: K_{Ra} (lb-mole/ft-yr) | Average-Fitting Seals: K_{Rb} [lb-mole/(mph) ⁿ -ft-yr] | Average-Fitting Seals: n (dimensionless) |
|---|--|--|---|
| Welded Tanks Mechanical-shoe seal Primary only ^b | 5.8 | 0.3 | 2.1 |
| Welded Tanks Mechanical-shoe seal Shoe-mounted secondary | 1.6 | 0.3 | 1.6 |
| Welded Tanks Mechanical-shoe seal Rim-mounted secondary | 0.6 | 0.4 | 1.0 |
| Welded Tanks Liquid-mounted seal Primary only | 1.6 | 0.3 | 1.5 |
| Welded Tanks Liquid-mounted seal Weather shield | 0.7 | 0.3 | 1.2 |
| Welded Tanks Liquid-mounted seal Rim-mounted secondary | 0.3 | 0.6 | 0.3 |
| Welded Tanks Vapor-mounted seal Primary only | 6.7 ^c | 0.2 | 3.0 |
| Welded Tanks Vapor-mounted seal Weather shield | 3.3 | 0.1 | 3.0 |
| Welded Tanks Vapor-mounted seal Rim-mounted secondary | 2.2 | 0.003 | 4.3 |
| Riveted Tanks - Mechanical-shoe seal Primary only | 10.8 | 0.4 | 2.0 |
| Riveted Tanks - Mechanical-shoe seal Shoe-mounted secondary | 9.2 | 0.2 | 1.9 |
| Riveted Tanks - Mechanical-shoe seal Rim-mounted secondary | 1.1 | 0.3 | 1.5 |

| Tank Construction And Rim-Seal System for Welded Tanks | Tight-Fitting ^d Seals: K_{Ra} (lb-mole/ft-yr) | Tight-Fitting ^d Seals: K_{Rb} [lb-mole/(mph) ⁿ -ft-yr] | Tight-Fitting ^d Seals: n (dimensionless) |
|--|---|---|--|
| Mechanical-shoe seal Primary only | 1.5 | 0.4 | 1.9 |
| Mechanical-shoe seal Shoe-mounted secondary | 1.0 | 0.4 | 1.5 |
| Mechanical-shoe seal Rim-mounted secondary | 0.4 | 0.4 | 1.0 |
| Liquid-mounted seal Primary only | 1.0 | 0.08 | 1.8 |
| Liquid-mounted seal Weather shield | 0.4 | 0.2 | 1.3 |
| Liquid-mounted seal Rim-mounted secondary | 0.2 | 0.4 | 0.4 |
| Vapor-mounted seal Primary only | 5.6 | 0.2 | 2.4 |
| Vapor-mounted seal Weather shield | 2.8 | 0.1 | 2.3 |
| Vapor-mounted seal Rim-mounted secondary | 2.2 | 0.02 | 2.6 |

Note: The rim-seal loss factors K_{Ra} , K_{Rb} , and n may only be used for wind speeds below 15 miles per hour.

^a References 5 and 15.

^b If no specific information is available, a welded tank with an average-fitting mechanical-shoe primary seal can be used to represent the most common or typical construction and rim-seal system in use for external and domed external floating roof tanks.

^c If no specific information is available, this value can be assumed to represent the most common or typical rim-seal system currently in use for internal floating roof tanks.

^d “Tight-fitting” means that the rim seal is maintained with no gaps greater than 1/8 in. wide between the rim seal and the tank shell. It is not appropriate to use the values for tight-fitting seals unless the seal is known to be maintained with gaps no greater than 1/8 in. through the full range of liquid level in the tank.

Table 7.1-9. RESERVED

Table 7.1-10. Average Clingage Factors, C_s (bbl/10³ ft²)^a

| Product Stored | Shell Condition Light Rust | Shell Condition Dense Rust | Shell Condition Gunite Lining |
|-------------------------|-------------------------------|-------------------------------|----------------------------------|
| Gasoline | 0.0015 | 0.0075 | 0.15 |
| Single-component stocks | 0.0015 | 0.0075 | 0.15 |
| Crude oil | 0.0060 | 0.030 | 0.60 |

^a Reference 5. If no specific information is available, the values in this table can be assumed to represent the most common or typical condition of tanks currently in use.

Table 7.1-11. Typical Number Of Columns As A Function Of Tank Diameter For Internal Floating Roof Tanks With Column Supported Fixed Roofs^a

| Tank Diameter Range D, (ft) | Typical Number Of Columns, N_c |
|-----------------------------|----------------------------------|
| 0 < D ≤ 85 | 1 |
| 85 < D ≤ 100 | 6 |
| 100 < D ≤ 120 | 7 |
| 120 < D ≤ 135 | 8 |
| 135 < D ≤ 150 | 9 |
| 150 < D ≤ 170 | 16 |
| 170 < D ≤ 190 | 19 |
| 190 < D ≤ 220 | 22 |
| 220 < D ≤ 235 | 31 |
| 235 < D ≤ 270 | 37 |
| 270 < D ≤ 275 | 43 |
| 275 < D ≤ 290 | 49 |
| 290 < D ≤ 330 | 61 |
| 330 < D ≤ 360 | 71 |
| 360 < D ≤ 400 | 81 |

^a Reference 5. This table was derived from a survey of users and manufacturers. The actual number of columns in a particular tank may vary greatly with age, fixed roof style, loading specifications, and manufacturing prerogatives. Data in this table should not be used when actual tank data are available.

Table 7.1-12. Deck-Fitting Loss Factors, K_{Fa} , K_{Fb} , and m , and Typical Number Of Deck Fittings, N_F ^a

| Fitting Type And Construction Details ^a | Loss Factor K_{Fa} (lb-mole/yr) | Loss Factor K_{Fb} (lb-mole/(mph) ^m -yr) | Loss Factor m (dimensionless) | Typical Number Of Fittings, N_F |
|---|--------------------------------------|--|------------------------------------|--------------------------------------|
| Access hatch Bolted cover, gasketed ^b | 1.6 | 0 | 0 | 1 |
| Access hatch Unbolted cover, ungasketed | 36 ^c | 5.9 | 1.2 | 1 |
| Access hatch Unbolted cover, gasketed | 31 | 5.2 | 1.3 | 1 |
| Fixed roof support column well ^d Round pipe, ungasketed sliding cover | 31 | p | | N_C (Table 7.1-11) |
| Fixed roof support column well ^d Round pipe, gasketed sliding cover | 25 | P | | N_C (Table 7.1-11) |
| Fixed roof support column well ^d Round pipe, flexible fabric sleeve seal | 10 | p | | N_C (Table 7.1-11) |
| Fixed roof support column well ^d Built-up column, ungasketed sliding cover ^c | 51 | p | | N_C (Table 7.1-11) |
| Fixed roof support column well ^d Built-up column, gasketed sliding cover | 33 | p | | N_C (Table 7.1-11) |
| Unslotted guidepole and well Ungasketed sliding cover | 31 | 150 | 1.4 | f |
| Unslotted guidepole and well Ungasketed sliding cover w/pole sleeve | 25 | 2.2 | 2.1 | f |
| Unslotted guidepole and well Gasketed sliding cover | 25 | 13 | 2.2 | f |
| Unslotted guidepole and well Gasketed sliding cover w/pole wiper | 14 | 3.7 | 0.78 | f |
| Unslotted guidepole and well Gasketed sliding cover w/pole sleeve | 8.6 | 12 | 0.81 | f |
| Slotted guidepole/sample well ^e Ungasketed or gasketed sliding cover | 43 | 270 | 1.4 | f |
| Slotted guidepole/sample well ^e Ungasketed or gasketed sliding cover, with float ^g | 31 | 36 | 2.0 | f |
| Slotted guidepole/sample well ^e Gasketed sliding cover, with pole wiper | 41 | 48 | 1.4 | f |
| Slotted guidepole/sample well ^e Gasketed sliding cover, with pole sleeve | 11 | 46 | 1.4 | f |
| Slotted guidepole/sample well ^e Gasketed sliding cover, with pole sleeve and pole wiper | 8.3 | 4.4 | 1.6 | f |
| Slotted guidepole/sample well ^e Gasketed sliding cover, with float and pole wiper ^g | 21 | 7.9 | 1.8 | f |
| Slotted guidepole/sample well ^e Gasketed sliding cover, with float, pole sleeve, and pole wiper ^h | 11 | 9.9 | 0.89 | f |
| Slotted guidepole/sample well ^e Flexible enclosure ⁱ | 21 | 7.9 | 1.8 | f |
| Gauge-float well (automatic gauge) Unbolted cover, ungasketed ^b | 14 ^c | 5.4 | 1.1 | 1 |
| Gauge-float well (automatic gauge) Unbolted cover, gasketed | 4.3 | 17 | 0.38 | 1 |
| Gauge-float well (automatic gauge) Bolted cover, gasketed | 2.8 | 0 | 0 | 1 |

| Fitting Type And Construction Details ^a | Loss Factor K_{Fa} (lb-mole/yr) | Loss Factor K_{Fb} (lb-mole/(mph) ^m -yr) | Loss Factor m (dimensionless) | Typical Number Of Fittings, N_f |
|--|--------------------------------------|--|------------------------------------|--|
| Gauge-hatch/sample port Weighted mechanical actuation, gasketed ^b | 0.47 | 0.02 | 0.97 | 1 |
| Gauge-hatch/sample port Weighted mechanical actuation, ungasketed | 2.3 | 0 | 0 | 1 |
| Gauge-hatch/sample port Slit fabric seal, 10% open area ^c | 12 | p | | 1 |
| Vacuum breaker Weighted mechanical actuation, ungasketed | 7.8 | 0.01 | 4.0 | N_{vb} (Table 7.1-13) ^j |
| Vacuum breaker Weighted mechanical actuation, gasketed ^b | 6.2 ^c | 1.2 | 0.94 | N_{vb} (Table 7.1-13) ^j |
| Deck drain (3-inch diameter) Open ^b | 1.5 | 0.21 | 1.7 | N_d (Table 7.1-13) |
| Deck drain (3-inch diameter) 90% closed | 1.8 | 0.14 | 1.1 | N_d (Table 7.1-15) |
| Deck drain (3-inch diameter) Stub drain (1-inch diameter) ^k | 1.2 | p | 1.1 | |
| Deck leg, IFR-type (total sleeve length approx. 12 inches) ^m Adjustable ^c | 7.9 | p | | N_i (Table 7.1-15) |
| Deck leg, EFR-type (pontoon area of pontoon roofs; total sleeve length approx. 30 inches) Adjustable - ungasketed ^b | 2.0 | 0.37 | 0.91 | N_i (Table 7.1-14) |
| Deck leg, EFR-type (pontoon area of pontoon roofs; total sleeve length approx. 30 inches) Adjustable - gasketed | 1.3 | 0.08 | 0.65 | N_i (Table 7.1-14) |
| Deck leg, EFR-type (pontoon area of pontoon roofs; total sleeve length approx. 30 inches) Adjustable - sock | 1.2 | 0.14 | 0.65 | N_i (Table 7.1-14) |
| Deck leg, EFR-type (double-deck roofs and center area of pontoon roofs, total sleeve length approx. 48 inches) Adjustable - ungasketed ^b | 0.82 | 0.53 | 0.14 | N_i (Table 7.1-14) |
| Deck leg, EFR-type (double-deck roofs and center area of pontoon roofs, total sleeve length approx. 48 inches) Adjustable - gasketed | 0.53 | 0.11 | 0.13 | N_i (Table 7.1-14) |
| Deck leg, EFR-type (double-deck roofs and center area of pontoon roofs, total sleeve length approx. 48 inches) Adjustable - sock | 0.49 | 0.16 | 0.14 | N_i (Table 7.1-14) |
| Deck leg or hanger (no opening through deck) Fixed | 0 | | 0 | N_i may be set as 0 (no openings) |
| Rim vent ⁿ Weighted mechanical actuation, ungasketed | 0.68 | 1.8 | 1.0 | 1 |
| Rim vent ⁿ Weighted mechanical actuation, gasketed ^b | 0.71 | 0.10 | 1.0 | 1 |

| Fitting Type And Construction Details ^a | Loss Factor K_{Fa} (lb-mole/yr) | Loss Factor K_{Fb} (lb-mole/(mph) ^m -yr) | Loss Factor m (dimensionless) | Typical Number Of Fittings, N_f |
|--|--------------------------------------|--|----------------------------------|--------------------------------------|
| Ladder well Sliding cover, ungasketed ^c | 98 | p | | 1 ^d |
| Ladder well Sliding cover, gasketed | 56 | p | | 1 ^d |
| Ladder-slotted guidepole combination well Sliding cover, ungasketed | 98 | p | | 1 ^d |
| Ladder-slotted guidepole combination well Ladder sleeve, ungasketed sliding cover | 65 | p | | 1 ^d |
| Ladder-slotted guidepole combination well Ladder sleeve, gasketed sliding cover | 60 | p | | 1 ^d |

Note: The deck-fitting loss factors, K_{Fa} , K_{Fb} , and m, may only be used for wind speeds below 15 miles per hour.

^a Reference 5, unless otherwise indicated.

^b If no specific information is available, this value can be assumed to represent the most common or typical deck fitting currently in use for external and domed external floating roof tanks.

^c If no specific information is available, this value can be assumed to represent the most common or typical deck fitting currently in use for internal floating roof tanks.

^d Column wells and ladder wells are not typically used with self-supported fixed roofs.

^e References 16,19.

^f There is no typical quantity or configuration of unslotted or slotted guidepoles, and thus tank specific data should be obtained.

^g Tests were conducted with floats positioned with the float wiper at and 1 inch above the sliding cover. The user is cautioned against applying these factors to floats that are positioned with the wiper or top of the float below the sliding cover ("short floats"). The emission factor for such a float is expected to be between the factors for a guidepole without a float and with a float, depending upon the position of the float top and/or wiper within the guidepole.

^h Tests were conducted with floats positioned with the float wiper at varying heights with respect to the sliding cover. This fitting configuration also includes a pole sleeve which restricts the airflow from the well vapor space into the slotted guidepole. Consequently, the float position within the guidepole (at, above, or below the sliding cover) is not expected to significantly affect emission levels for this fitting configuration, since the function of the pole sleeve is to restrict the flow of vapor from the vapor space below the deck into the guidepole.

ⁱ A flexible enclosure surrounds the guidepole from the gasketed cover at the deck opening up to an elevation on the guidepole above all slots or holes through the guidepole. EPA's Storage Tank Emission Reduction Partnership Program granted the flexible enclosure system equivalency to the pole float system. [65 FR 19891(04/13/00)]

^j $N_{vb} = 1$ for internal floating roof tanks.

^k Stub drains are not used on welded contact internal floating decks.

^m Loss factors for EFR-type deck legs may be used for an IFR if the total height of the leg sleeves, including the portion extending down into the liquid, is similar to that of the EFR-type deck leg.

ⁿ Rim vents are used only with mechanical-shoe primary seals.

^p Deck fittings with only a K_{Fa} factor and no K_{Fb} or m factor should not be applied to external floating roof tanks because the emission factor for such deck fittings does not account for wind effects.

^q Emission factors for IFR deck fittings that are not listed in this table may be calculated using equation 2-17.

Table 7.1-13. External Floating Roof Tanks: Typical Number Of Vacuum Breakers, N_{vb} , and Deck Drains, N_d ^a

| Tank Diameter D (feet) ^b | Number Of Vacuum Breakers, N_{vb} Pontoon Roof | Number Of Vacuum Breakers, N_{vb} Double-Deck Roof | Number Of Deck drains, N_d |
|--|--|--|------------------------------|
| 50 | 1 | 1 | 1 |
| 100 | 1 | 1 | 1 |
| 150 | 2 | 2 | 2 |
| 200 | 3 | 2 | 3 |
| 250 | 4 | 3 | 5 |
| 300 | 5 | 3 | 7 |
| 350 | 6 | 4 | ND |
| 400 | 7 | 4 | ND |

^a Reference 5. This table was derived from a survey of users and manufacturers. The actual number of vacuum breakers may vary greatly depending on throughput and manufacturing prerogatives. The actual number of deck drains may also vary greatly depending on the design rainfall and manufacturing prerogatives. For tanks more than 350 feet in diameter, actual tank data or the manufacturer's recommendations may be needed for the number of deck drains. This table should not be used when actual tank data are available. ND = no data.

^b If the actual diameter is between the diameters listed, the closest diameter listed should be used. If the actual diameter is midway between the diameters listed, the next larger diameter should be used.

Table 7.1-14. External Floating Roof Tanks: Typical Number Of Roof Legs, NI ^a

| Tank Diameter, D (feet) ^b | Pontoon Roof Number Of Pontoon Legs | Pontoon Roof Number Of Center Legs | Number Of Legs On Double-Deck Roof |
|--------------------------------------|-------------------------------------|------------------------------------|------------------------------------|
| 30 | 4 | 2 | 6 |
| 40 | 4 | 4 | 7 |
| 50 | 6 | 6 | 8 |
| 60 | 9 | 7 | 10 |
| 70 | 13 | 9 | 13 |
| 80 | 15 | 10 | 16 |
| 90 | 16 | 12 | 20 |
| 100 | 17 | 16 | 25 |
| 110 | 18 | 20 | 29 |
| 120 | 19 | 24 | 34 |
| 130 | 20 | 28 | 40 |
| 140 | 21 | 33 | 46 |
| 150 | 23 | 38 | 52 |
| 160 | 26 | 42 | 58 |
| 170 | 27 | 49 | 66 |
| 180 | 28 | 56 | 74 |
| 190 | 29 | 62 | 82 |
| 200 | 30 | 69 | 90 |
| 210 | 31 | 77 | 98 |
| 220 | 32 | 83 | 107 |
| 230 | 33 | 92 | 115 |
| 240 | 34 | 101 | 127 |
| 250 | 35 | 109 | 138 |
| 260 | 36 | 118 | 149 |
| 270 | 36 | 128 | 162 |
| 280 | 37 | 138 | 173 |
| 290 | 38 | 148 | 186 |
| 300 | 38 | 156 | 200 |
| 310 | 39 | 168 | 213 |
| 320 | 39 | 179 | 226 |
| 330 | 40 | 190 | 240 |
| 340 | 41 | 202 | 255 |
| 350 | 42 | 213 | 270 |
| 360 | 44 | 226 | 285 |
| 370 | 45 | 238 | 300 |
| 380 | 46 | 252 | 315 |
| 390 | 47 | 266 | 330 |
| 400 | 48 | 281 | 345 |

^a Reference 5. This table was derived from a survey of users and manufacturers. The actual number of roof legs may vary greatly depending on age, style of floating roof, loading specifications, and manufacturing prerogatives. This table should not be used when actual tank data are available.

^b If the actual diameter is between the diameters listed, the closest diameter listed should be used. If the actual diameter is midway between the diameters listed, the next larger diameter should be used.

Table 7.1-15. Internal Floating Roof Tanks: Typical Number Of Deck Legs, N_L , and Stub Drains, N_d ^a

| Deck fitting type | Typical Number Of Fittings, N_F |
|---|--|
| Deck leg or hanger well ^b | $(5 + \frac{D}{10} + \frac{D^2}{600})$ |
| Stub drain (1-inch diameter) ^{b,c} | $(\frac{D^2}{125})$ |

^a Reference 5.

^b D = tank diameter, ft

^c Not used on welded contact internal floating decks.

Table 7.1-16. Deck Seam Length Factors (S_D) For Typical Deck Constructions For Internal Floating Roof Tanks ^a

| Deck Construction | Typical Deck Seam Length Factor, S_D (ft/ft ²) |
|--|---|
| Continuous sheet construction ^b - 5 ft wide | 0.20 ^c |
| Continuous sheet construction ^b - 6 ft wide | 0.17 |
| Continuous sheet construction ^b - 7 ft wide | 0.14 |
| Panel construction ^d - 5 x 7.5 ft rectangular | 0.33 |
| Panel construction ^d - 5 x 12 ft rectangular | 0.28 |

^a Reference 5. Deck seam loss applies to bolted decks only.

^b $S_D = 1/W$, where W = sheet width (ft).

^c If no specific information is available, this value can be assumed to represent the most common bolted decks currently in use.

^d $S_D = (L+W)/LW$, where W = panel width (ft) and L = panel length (ft).

Table 7.1-17. Roof Landing Losses For Internal Or Domed External Floating Roof Tank With A Liquid Heel^a

| | |
|---------------------------------|---|
| Standing Idle Loss | $L_{SL} = n_d K_E \frac{P_V V_V}{R T_V} M_V K_S$ <p style="text-align: right;">Equation 3-7</p> |
| Standing Idle Loss | $L_{SLmax} = 5.9 D^2 h_{ie} W_L$ <p style="text-align: right;">Equation 3-4</p> |
| Standing Idle Saturation Factor | $K_S = \frac{1}{1 + 0.053 P_{VA} H_{VO}}$ <p>Where H_{VO} is set equal to h_v.</p> $K_S \leq S$ <p style="text-align: right;">Equation 1-23</p> |
| Filling Loss Equation | $L_{FL} = \left(\frac{P_{VA} V_V}{R T_V} \right) M_V (C_{sf} S)$ <p>Where C_{sf} is set equal to 1.</p> <p style="text-align: right;">Equation 3-18</p> |
| Filling Loss Equation | $L_{FL} \leq (5.9 D^2 h_{ie} W_L) - L_{SL} + 0.15 \frac{P_{VA} V_V}{R T_V} M_V$ <p style="text-align: right;">Equation 3-16</p> |
| Filling Saturation Factor (S) | <p>S = 0.60 for a full liquid heel</p> <p>S = 0.50 for a partial liquid heel</p> |

^a Reference 21.

Table 7.1-18. Roof Landing Losses For External Floating Roof Tank With A Liquid Heel ^a

| | | |
|---------------------------------|---|---------------|
| Standing Idle Loss | $L_{SL\ wind} = 0.57 n_D DP^* M_V$ | Equation 3-10 |
| Standing Idle Loss | $L_{SLmax} = 5.9 D^2 h_{ie} W_L$ | Equation 3-4 |
| Standing Idle Saturation Factor | Not applicable | |
| Filling Loss Equation | $L_{FL} = \left(\frac{P_{VA} V_V}{R T_V} \right) M_V (C_{sf} S)$ | Equation 3-18 |
| | $C_{sf} = 1 - \left(\frac{(0.57 \cdot 1 \cdot D \cdot P^* \cdot M_V) - \left(1 \cdot K_E \left(\frac{P_{VA} V_V}{R T_V} \right) \cdot M_V \cdot K_S \right)}{\left(1 \cdot K_E \left(\frac{P_{VA} V_V}{R T_V} \right) \cdot M_V \cdot K_S \right) + \left(\left(\frac{P_{VA} V_V}{R T_V} \right) \cdot M_V \cdot (1 \cdot S) \right)} \right)$ | Equation 3-21 |
| Filling Loss Equation | $L_{FL} \leq (5.9 D^2 h_{ie} W_L) - L_{SL} + 0.15 \frac{P_{VA} V_V}{R T_V} M_V$ | Equation 3-16 |
| Filling Saturation Factor (S) | <p>S = 0.6 for a full liquid heel S = 0.5 for a partial liquid heel</p> <p>$C_{sf} S \geq 0.15$</p> | |

^a Reference 21.

Table 7.1-19. Roof Landing Losses For All Drain-Dry Tanks^a

| | | |
|---------------------------------|--|---------------|
| Standing Idle Loss | $L_{SL} = 0.0063 W_L \frac{\pi D^2}{4}$ | Equation 3-13 |
| Standing Idle Loss | $L_{SL} \leq 0.60 \frac{P_{VA} V_V}{R T_V} M_V$ | Equation 3-15 |
| Standing Idle Saturation Factor | Not applicable | |
| Filling Loss Equation | $L_{FL} = \left(\frac{P_{VA} V_V}{R T_V} \right) M_V (C_{sf} S)$ <p>Where C_{sf} is set equal to 1.</p> | Equation 3-18 |
| Filling Saturation Factor (S) | S = 0.15 | |

^a Reference 21.

Table 7.1-20. Tank Cleaning Equations – Vapor Space Purge Emissions^a

| | |
|---------------------------|---|
| Vapor Space Purge | $L_P = \frac{P_{VA} V_V}{R T_V} M_V S$ <p style="text-align: right;">Equation 4-2</p> |
| Vapor Space Volume, V_V | <p><u>Fixed Roof Tank</u></p> $V_V = H_{VO} (\pi D^2/4)$ <p style="text-align: right;">Equation 4-3</p> <p>where: H_{VO} = the fixed-roof tank vapor space outage (ft)</p> |
| Vapor Space Volume, V_V | <p><u>Floating Roof Tank</u></p> $V_V = h_v (\pi D^2/4)$ <p style="text-align: right;">Equation 4-9</p> <p>where: h_v = the height of the vapor space under the landed floating roof (ft)</p> |
| Saturation Factor, S | <p><u>Fixed Roof Tank</u></p> $S = (0.5 n_d + 1) / 6$ <p style="text-align: right;">Equation 4-6</p> <p>where: n_d = period of time standing idle after emptying and before commencement of forced ventilation (days)</p> $S \geq 0.25$ <p style="text-align: right;">Equation 4-7</p> $S \leq 0.5$ <p style="text-align: right;">Equation 4-8</p> |
| Saturation Factor, S | <p><u>Floating Roof Tank (function of heel condition and tank type)</u></p> $S = 0.6 C_{sf}$ full liquid heel $S = 0.5 C_{sf}$ partial liquid heel $S = 0$ drain dry tanks <p>where: $C_{sf} = 1.0$ for IFRTs (and Domed EFRTs); C_{sf} evaluated per Equation 3-21 for EFRTs for the initial vapor space purge; set to 1.0 for subsequent vapor space purges that follow ventilation having been shut off overnight.</p> |

^a Reference 23.

Table 7.1-21. Tank Cleaning Equations – Continued Forced Ventilation Emissions ^a

| | |
|------------------------------|--|
| Continued Forced Ventilation | $L_{CV} = 60 Q_V n_{CV} t_V C_V \left(\frac{P_a M_{CG}}{RT_V} \right)$ <p style="text-align: right;">Equation 4-10</p> |
| Prior Stock Remains | $L_{CV} \leq 5.9 D^2 h_{ie} W_L$ <p style="text-align: right;">Equation 4-12</p> |
| Distillate Flushing | If liquid is being circulated through the tank, there would be no mass-based limit on emissions in that the liquid is being continually replenished. If a fixed amount of liquid is added to the tank, emissions could not then exceed the mass of the remaining heel plus the added distillate. |
| Only Sludge Remains | $L_{CV} = 0.49 D^2 F_e d_s W_L$ <p style="text-align: right;">Equation 4-13</p> |

^a Reference 23.

7.1.7 Sample Calculations

The examples given in this section present estimated emissions to two significant figures. This level of precision is chosen arbitrarily and may overstate the accuracy of the loss estimates given the uncertainty associated with the multiple parameters affecting emissions from storage tanks.

Example 1 - Chemical Mixture in a Vertical Fixed Roof Tank

Determine the yearly emission rate of the total product mixture and each component for a chemical mixture stored in a vertical cone roof tank in Denver, Colorado. The chemical mixture contains (for every 3,171 lb of mixture) 2,812 lb of benzene, 258 lb of toluene, and 101 lb of cyclohexane. The tank is 6 ft in diameter, 12 ft high, usually holds about 8 ft of product, and is painted white. The shell is light gray. The liquid level typically ranges between 4.5 feet and 11.5 feet, and thus the tank working volume is 1,480 gallons. The throughput of the tank is 8,450 gal/yr. The liquid bulk temperature is not known, but the tank is not insulated and storage conditions are in approximate equilibrium with ambient conditions.

Example 1 Solution

1. Determine tank type. The tank is a fixed-cone roof, vertical tank.
2. Determine estimating methodology. The product is made up of three organic liquids, all of which are miscible in each other, which makes a homogenous mixture if the material is well mixed. The tank emission rate will be based upon the properties of the mixture. Raoult's Law (as discussed in the Speciation Section) is assumed to apply to the mixture and will be used to determine the properties of the mixture.
3. Select equations to be used. For a vertical, fixed roof storage tank, the following equations apply:

$$L_T = L_S + L_W \quad (1-1)$$

$$L_S = 365 V_V W_V K_E K_S \quad (1-2)$$

$$L_W = V_Q K_N K_P W_V K_B \quad (1-37)$$

where:

L_T = total loss, lb/yr

L_S = standing loss, lb/yr

L_W = working loss, lb/yr

V_V = tank vapor space volume, ft³

$$V_V = \pi/4 D^2 H_{VO} \quad (1-3)$$

W_V = vapor density, lb/ft³

$$W_V = \frac{M_V P_{VA}}{R T_V} \quad (1-24)$$

K_E = vapor space expansion factor, per day

$$K_E = \frac{\Delta T_V}{T_{LA}} + \frac{\Delta P_V - \Delta P_B}{P_A - P_{VA}} \quad (1-5)$$

K_S = vented vapor space saturation factor, dimensionless

$$K_S = \frac{1}{1 + 0.053 P_{VA} H_{VO}} \quad (1-23)$$

D = diameter, ft

H_{VO} = vapor space outage, ft

M_V = molecular weight of vapor, lb/lb-mole

P_{VA} = vapor pressure at the average daily liquid surface temperature, psia

R = ideal gas constant = $\frac{10.731 \text{ psia} \cdot \text{ft}^3}{\text{lb-mole} \cdot ^\circ\text{R}}$

T_V = average vapor temperature, $^\circ\text{R}$

T_{LA} = average daily liquid surface temperature, $^\circ\text{R}$

ΔT_V = average daily vapor temperature range, $^\circ\text{R}$

ΔP_V = average daily vapor pressure range, psia

ΔP_B = breather vent pressure setting range, psi

P_A = atmospheric pressure, psia

V_Q = net working loss throughput, ft^3/yr

K_N = working loss turnover factor, dimensionless

K_P = working loss product factor, dimensionless

K_B = vent setting correction factor, dimensionless

4. Calculate each component of the standing loss and working loss functions.

a. Tank vapor space volume, V_V :

$$V_V = (\pi/4) D^2 H_{VO} \quad (1-3)$$

where:

D = 6 ft (given)

For a cone roof, the vapor space outage, H_{VO} is calculated by:

$$H_{VO} = H_S - H_L + H_{RO} \quad (1-18)$$

where:

H_S = tank shell height, 12 ft (given)

H_L = stock liquid height, 8 ft (given)

$$H_{RO} = \text{roof outage, } 1/3 H_R = 1/3(S_R)(R_S) \quad (1-19)$$

S_R = tank cone roof slope, 0.0625 ft/ft (given) (see Note 1 to Equation 1-18)

R_S = tank shell radius = $1/2 D = 1/2 (6) = 3$

Substituting values in Equation 1-19 yields,

$$H_{RO} = (1/3) (0.0625)(3) = 0.0625 \text{ ft}$$

Then use Equation 1-18 to calculate H_{VO} ,

$$H_{VO} = 12 - 8 + 0.0625 = 4.0625 \text{ ft}$$

Therefore,

$$V_V = \frac{\pi}{4} (6)^2 (4.0625) = 114.86 \text{ ft}^3$$

b. Vapor density, W_V :

$$W_V = \frac{M_V P_{VA}}{R T_V} \quad (1-24)$$

where:

$$R = \text{ideal gas constant} = \frac{10.731 \text{ psia} \cdot \text{ft}^3}{\text{lb} - \text{mole} \cdot ^\circ\text{R}}$$

M_V = stock vapor molecular weight, lb/lb-mole

P_{VA} = stock vapor pressure at the average daily liquid surface temperature T_{LA} , psia

T_V = average vapor temperature, $^\circ\text{R}$

First, calculate T_{LA} using Equation 1-29.

$$T_{LA} = \left(0.5 - \frac{0.8}{4.4(H_S/D) + 3.8} \right) T_{AA} + \left(0.5 + \frac{0.8}{4.4(H_S/D) + 3.8} \right) T_B + \frac{0.021 \alpha_R I + 0.013(H_S/D) \alpha_S I}{4.4(H_S/D) + 3.8} \quad (1-29)$$

where:

H_S = tank shell height = 12 ft (given)

D = tank diameter = 6 ft (given),

T_{AA} = average daily ambient temperature, $^\circ\text{R}$;

T_B = liquid bulk temperature, $^\circ\text{R}$;

α_R = tank roof surface solar absorptance = 0.25 (see Table 7.1-6, for white paint in average condition)

α_S = tank shell surface solar absorptance = 0.58 (see Table 7.1-6, for light gray paint in average condition)

I = average daily total insolation factor, Btu/(ft² day) = 1,491 (see Table 7.1-7)

T_{AA} and T_B must be calculated from Equations 1-32 and 1-33.

$$T_{AA} = \frac{T_{AX} + T_{AN}}{2} \quad (1-32)$$

$$T_B = T_{AA} + 0.003 \alpha_S I \quad (1-33)$$

from Table 7.1-7, for Denver, Colorado:

T_{AX} = average daily maximum ambient temperature = 63.5 °F

T_{AN} = average daily minimum ambient temperature = 37.9°F

Converting to °R:

$$T_{AX} = 63.5 + 459.67 = 523.2 \text{ °R}$$

$$T_{AN} = 37.9 + 459.67 = 497.6 \text{ °R}$$

Therefore,

$$T_{AA} = (523.2 + 497.6)/2 = 510.37 \text{ °R}$$

$$T_B = \text{liquid bulk temperature} = T_{AA} + 0.003 \alpha_S I$$

α_S = surface solar absorptance = 0.58 (see Table 7.1-6)

I = average daily total insolation on a horizontal surface = 1,491 Btu/ft²•d (see Table 7.1-7)

Substituting values in Equation 1-33

$$T_B = 510.37 + 0.003 (0.58) 1,491 = 512.96 \text{ °R}$$

Using Equation 1-29,

$$T_{LA} = \left(0.5 - \frac{0.8}{4.4(H_S/D) + 3.8} \right) T_{AA} + \left(0.5 + \frac{0.8}{4.4(H_S/D) + 3.8} \right) T_B + \frac{0.021 \alpha_R I + 0.013(H_S/D) \alpha_S I}{4.4(H_S/D) + 3.8}$$

$$T_{LA} = \left(0.5 - \frac{0.8}{4.4 \left(\frac{12}{6} \right) + 3.8} \right) * 510.37 + \left(0.5 + \frac{0.8}{4.4 \left(\frac{12}{6} \right) + 3.8} \right) * 512.96 + (0.021 * 0.25 * 1491 + 0.13 (12/6) * 0.58 * 1491) / (4.4 * (12/6) + 3.8)$$

$$T_{LA} = 514.24 \text{ °R}$$

Second, calculate P_{VA} using Raoult's Law.

According to Raoult's Law, the partial pressure of a component is the product of its pure vapor pressure and its liquid mole fraction. The total vapor pressure of the component mixture stock is equal to the sum of the partial pressures of its components.

The pure vapor pressures for benzene, toluene, and cyclohexane can be calculated from Antoine's equation. Table 7.1-3 provides the Antoine's coefficients for benzene, which are $A = 6.906$, $B = 1,211.0$,

and C = 220.79. For toluene, A = 7.017, B = 1,377.6, and C = 222.64. For cyclohexane, A = 6.845, B = 1,203.5, and C = 222.86. Therefore:

$$\log P = A - \frac{B}{T + C}$$

$$T_{LA}, \text{ average liquid surface temperature } (^{\circ}\text{C}) = (514.24 - 491.67)/1.8 = 12.54$$

For benzene,

$$\log P = 6.906 - \frac{1,211.0}{12.54 + 220.79}$$

$$\log P = 1.7159 \text{ mmHg}$$

$$P = 10^{1.7159} = 51.99 \text{ mmHg} = 1.005 \text{ psia}$$

Similarly, for toluene and cyclohexane:

$$P = 0.279 \text{ psia for toluene}$$

$$P = 1.044 \text{ psia for cyclohexane}$$

In order to calculate the mixture vapor pressure, the partial pressures need to be calculated for each component. The partial pressure is the product of the pure vapor pressures of each component (calculated above) and the mole fractions of each component in the liquid.

The mole fractions of each component are calculated as follows:

| Component | Amount, lb | M _i | Moles | x _i |
|-------------|------------|----------------|-------|----------------|
| Benzene | 2,812 | 78.11 | 36.0 | 0.90 |
| Toluene | 258 | 92.14 | 2.80 | 0.07 |
| Cyclohexane | 101 | 84.16 | 1.20 | 0.03 |
| Total | | | 40.0 | 1.00 |

where:

M_i = molecular weight of component

x_i = liquid mole fraction

The partial pressures of the components can then be calculated by multiplying the pure vapor pressure by the liquid mole fraction as follows:

| Component | P at 53.2°F | x _i | P _{partial} |
|-------------|-------------|----------------|----------------------|
| Benzene | 1.005 | 0.90 | 0.9045 |
| Toluene | 0.279 | 0.07 | 0.0195 |
| Cyclohexane | 1.044 | 0.03 | 0.0313 |
| Total | | 1.0 | 0.9553 |

The vapor pressure of the mixture is then 0.9553 psia.

Third, calculate the molecular weight of the vapor, M_v . Molecular weight of the vapor depends upon the mole fractions of the components in the vapor.

$$M_v = \sum M_i y_i$$

where:

M_i = molecular weight of the component

y_i = vapor mole fraction

The vapor mole fractions, y_i , are equal to the partial pressure of the component divided by the total vapor pressure of the mixture.

Therefore,

$$y_{\text{benzene}} = P_{\text{partial}}/P_{\text{total}} = 0.9045/0.9553 = 0.947$$

Similarly, for toluene and cyclohexane,

$$y_{\text{toluene}} = P_{\text{partial}}/P_{\text{total}} = 0.020$$

$$y_{\text{cyclohexane}} = P_{\text{partial}}/P_{\text{total}} = 0.033$$

The mole fractions of the vapor components sum to 1.0.

The molecular weight of the vapor can be calculated using the following equation:

$$M_v = \sum M_i y_i$$

Calculated values are shown in the next table:

| Component | M_i | y_i | M_v |
|-------------|-------|-------|-------|
| Benzene | 78.11 | 0.947 | 73.97 |
| Toluene | 92.14 | 0.020 | 1.84 |
| Cyclohexane | 84.16 | 0.033 | 2.78 |
| Total | | 1.0 | 78.59 |

Now calculate T_v using Equation 1-34.

$$T_v = \frac{[2.2 (H_S/D) + 1.1] T_{AA} + 0.8 T_B + 0.021 \alpha_R I + 0.013 (H_S/D) \alpha_S I}{2.2 (H_S/D) + 1.9} \quad (1-34)$$

$$T_v = \frac{[(2.2 (12/6) + 1.1) * 510.4 + 0.8 * 512.96 + 0.021 * 0.25 * 1491 + 0.013 * (12/6) * 0.58 * 1491]}{(2.2 (12/6) + 1.9)}$$

$$T_v = \frac{[(5.5) * 510.4 + 0.8 * 512.96 + 7.82 + 22.48]}{[6.3]}$$

$$T_v = \frac{[2807.2 + 410.4 + 7.82 + 22.48]}{[6.3]}$$

$$T_v = 515.5 \text{ } ^\circ\text{R}$$

Since all variables have now been solved, the stock density, W_V , can be calculated:

$$W_V = \frac{M_V P_{VA}}{R T_V}$$

$$W_V = \frac{(78.6)(0.9553)}{(10.731)(515.5)}$$

$$W_V = 1.36 \times 10^{-2} \text{ lb/ft}^3$$

c. Vapor space expansion factor, K_E :

$$K_E = \frac{\Delta T_V}{T_{LA}} + \frac{\Delta P_V - \Delta P_B}{P_A - P_{VA}} \quad (1-5)$$

where:

ΔT_V = average daily vapor temperature range, °R

ΔP_V = average daily vapor pressure range, °R

ΔP_B = breather vent pressure setting range, psia

P_A = atmospheric pressure, 12.08 psia for Denver, Colorado

P_{VA} = vapor pressure at average daily liquid surface temperature, psia = 0.9553 psia (from Step 4b)

T_{LA} = average daily liquid surface temperature, °R = 514.24°R (from Step 4b)

First, calculate the average daily vapor temperature range from Equation 1-6:

$$\Delta T_V = \left(1 - \frac{0.8}{2.2 (H_S/D) + 1.9}\right) \Delta T_A + \frac{0.042\alpha_R I + 0.026(H_S/D)\alpha_S I}{2.2 (H_S/D) + 1.9} \quad (1-6)$$

where:

ΔT_V = average daily vapor temperature range, °R

H_S = tank shell height, 12 ft (given)

D = tank diameter, 6 ft (given)

ΔT_A = average daily ambient temperature range, °R = $T_{AX} - T_{AN}$

α_R = tank roof surface solar absorptance, 0.25 (given)

α_S = tank shell surface solar absorptance, 0.58 (given)

I = average daily total insolation factor, 1,491 Btu/ft² d (given)

from Table 7.1-7, for Denver, Colorado:

$$T_{AX} = 63.5^\circ\text{F}$$

$$T_{AN} = 37.9^\circ\text{F}$$

Converting to °R,

$$T_{AX} = 63.5 + 459.67 = 523.2^\circ\text{R}$$

$$T_{AN} = 37.9 + 459.67 = 497.6^{\circ}\text{R}$$

From Equation 1-11: $\Delta T_A = T_{AX} - T_{AN}$

$$\Delta T_A = 523.2 - 497.6 = 25.6^{\circ}\text{R}$$

Therefore,

$$\begin{aligned} \Delta T_V &= [1 - (0.8 / (2.2 (12/6) + 1.9))] * 25.6 + (0.042 * 0.25 * 1491 + 0.026 * (12/6) * 0.58 * 1491) / (2.2 (12/6) + 1.9) \\ &= (1 - (0.8 / 6.3)) * 25.6 + (15.656 + 44.969) / 6.3 \\ &= 22.35 + 9.62 \\ &= 31.97^{\circ}\text{R} \end{aligned}$$

Second, calculate the average daily vapor pressure range using Equation 1-9:

$$\Delta P_V = P_{VX} - P_{VN} \quad (1-9)$$

P_{VX} , P_{VN} = vapor pressures at the average daily maximum, minimum liquid temperatures can be calculated in a manner similar to the P_{VA} calculation shown earlier.

T_{LX} = maximum liquid temperature, $T_{LA} + 0.25 \Delta T_V$ (from Figure 7.1-17)

T_{LN} = minimum liquid temperature, $T_{LA} - 0.25 \Delta T_V$ (from Figure 7.1-17)

T_{LA} = 514.24 (from Step 4b)

ΔT_V = 31.97°R

T_{LX} = 514.24 + (0.25) (31.97) = 522.23°R or 62.56°F

T_{LN} = 514.24 - (0.25) (31.97) = 506.25°R or 46.58°F

Using Antoine's equation, the pure vapor pressures of each component at the minimum liquid surface temperature are:

$$P_{\text{benzene}} = 0.797 \text{ psia}$$

$$P_{\text{toluene}} = 0.215 \text{ psia}$$

$$P_{\text{cyclohexane}} = 0.833 \text{ psia}$$

The partial pressures for each component at T_{LN} can then be calculated using this equation:

$$P_i = (P)(x_i) \quad (40-3)$$

where:

P_i = partial pressure of component i, psia

P = vapor pressure of pure component i at 46.58 °F, psia

x_i = liquid mole fraction, lb-mole/lb-mole

| Component | P at 46.58°F | x _i | P _i |
|-------------|--------------|----------------|----------------|
| Benzene | 0.797 | 0.90 | 0.717 |
| Toluene | 0.215 | 0.07 | 0.015 |
| Cyclohexane | 0.833 | 0.03 | 0.025 |
| Total | | 1.0 | 0.757 |

Using Antoine's equation, the pure vapor pressures of each component at the maximum liquid surface temperature are:

$$P_{\text{benzene}} = 1.257 \text{ psia}$$

$$P_{\text{toluene}} = 0.358 \text{ psia}$$

$$P_{\text{cyclohexane}} = 1.299 \text{ psia}$$

The partial pressures for each component at T_{LX} can then be calculated as follows:

| Component | P at 62.56°F | x _i | P _i |
|-------------|--------------|----------------|----------------|
| Benzene | 1.257 | 0.90 | 1.131 |
| Toluene | 0.358 | 0.07 | 0.025 |
| Cyclohexane | 1.299 | 0.03 | 0.039 |
| Total | | 1.0 | 1.195 |

Therefore, the vapor pressure range, $\Delta P_V = P_{LX} - P_{LN} = 1.195 - 0.757 = 0.438 \text{ psia}$.

Next, calculate the breather vent pressure, ΔP_B , from Equation 1-10:

$$\Delta P_B = P_{BP} - P_{BV} \quad (1-10)$$

where:

$$P_{BP} = \text{breather vent pressure setting} = 0.03 \text{ psia (given) (see Note 3 to Equation 1-5)}$$

$$P_{BV} = \text{breather vent vacuum setting} = -0.03 \text{ psig (given) (see Note 3 to Equation 1-5)}$$

$$\Delta P_B = 0.03 - (-0.03) = 0.06 \text{ psig}$$

$$P_A = 12.08 \text{ psia from Table 7.1-7, for Denver, Colorado}$$

Finally, K_E can be calculated by substituting values into Equation 1-5.

$$K_E = \frac{31.97}{514.24} + \frac{(0.438 - 0.06)}{(12.08 - 0.9553)}$$

$$K_E = 0.0961$$

d. Vented vapor space saturation factor, K_S:

$$K_S = \frac{1}{1 + 0.053 \frac{P_{VA}}{P_{V0}}} \quad (1-23)$$

where:

$$P_{VA} = 0.9553 \text{ psia (from Step 4b)}$$

$$H_{VO} = 4.0625 \text{ ft (from Step 4a)}$$

$$K_S = 1 / (1 + 0.053 * 0.9553 * 4.0625)$$

$$K_S = 0.829$$

Calculate standing losses.

$$L_S = 365 V_V W_V K_E K_S$$

Using the values calculated above:

$$W_V = 1.36 \times 10^{-2} \text{ lb/ft}^3 \text{ (from step 4b)}$$

$$V_V = 114.86 \text{ ft}^3 \text{ (from Step 4a)}$$

$$K_E = 0.0961 \text{ (from Step 4c)}$$

$$K_S = 0.829 \text{ (from Step 4d)}$$

$$L_S = 365 (1.36 \times 10^{-2})(114.86)(0.0961)(0.829) = 45.4 \text{ lb/yr}$$

6. Calculate working losses.

The amount of VOCs emitted as a result of filling operations can be calculated from the following equation:

$$L_W = V_Q K_N K_P W_V K_B \quad (1-37)$$

where:

$$V_Q = 5.614 Q \text{ (when } \Sigma H_{Qi} \text{ is unknown; equation 1-41)}$$

$$Q = 8,450 \text{ gal/yr} / 42 \text{ bbl/gal} = 201.2 \text{ bbl/yr (given)}$$

$$V_Q = 5.614 (201.2) \text{ ft}^3/\text{yr}$$

$$K_N = 1 \text{ for turnovers } N \leq 36 \text{ (given)}$$

$$K_P = \text{product factor, dimensionless} = 0.75 \text{ for crude oils, 1.0 for all other stocks}$$

$$N = \text{turnovers per year}$$

$$N = \Sigma H_{Qi} / (H_{LX} - H_{LN}) \quad (1-38)$$

$$\Sigma H_{Qi} = (5.614 Q) / ((\pi/4) D^2) \quad (1-39)$$

$$\Sigma H_{Qi} = (5.614) (201.2) / ((\pi/4) 6^2) = 39.9 \text{ ft}$$

$$H_{LX} = 11.5 \text{ ft (given)}$$

$$H_{LN} = 4.5 \text{ ft (given)}$$

$$N = 39.9 / (11.5 - 4.5) = 5.7$$

$$W_V = 1.36 \times 10^{-2} \text{ lb/ft}^3 \text{ (from Step 4b)}$$

$$K_B = 1 \text{ for vent settings of } \pm 0.03 \text{ psig (from Equation 1-37)}$$

$$L_W = (5.614) * (201.2) * (1) * (1) * (0.0136) (1) = 15.4 \text{ lb/yr}$$

7. Calculate total losses, L_T .

$$L_T = L_S + L_W$$

where:

$$L_S = 45.4 \text{ lb/yr}$$

$$L_W = 15.4 \text{ lb/yr}$$

$$L_T = 45.4 + 15.4 = 60.8 \text{ lb/yr}$$

8. Calculate the amount of each component emitted from the tank.

The amount of each component emitted is equal to the weight fraction of the component in the vapor times the amount of total VOC emitted. Assuming 100 moles of vapor are present, the number of moles of each component will be equal to the mole fraction multiplied by 100. This assumption is valid regardless of the actual number of moles present. The vapor mole fractions were determined in Step 4b. The weight of a component present in a mixture is equal to the product of the number of moles and molecular weight, M_i , of the component. The weight fraction of each component is calculated as follows:

$$\text{Weight fraction}_i = \frac{\text{pounds}_i}{\text{total pounds}}$$

Therefore,

| Component | No. of Moles ^a | M_i ^a | Pounds _i ^a | Weight fraction |
|-------------|-----------------------------|--------------------|----------------------------------|-----------------|
| Benzene | $(0.947 \times 100) = 94.7$ | 78.11 | 7,397 | 0.94 |
| Toluene | $(0.021 \times 100) = 2.1$ | 92.14 | 193 | 0.02 |
| Cyclohexane | $(0.033 \times 100) = 3.3$ | 84.16 | 278 | 0.04 |
| Total | 100 | | 7,868 | 1.0 |

^a No. of moles x M_i = Pounds_i

The amount of each component emitted is then calculated as:

$$\text{Emissions of component}_i = (\text{weight fraction}_i)(L_T)$$

| Component | Weight fraction ^a | Total VOC emitted, lb/yr ^a | Emissions, lb/yr ^a |
|-------------|------------------------------|---------------------------------------|-------------------------------|
| Benzene | 0.94 | 60.8 | 57.2 |
| Toluene | 0.02 | 60.8 | 1.2 |
| Cyclohexane | 0.04 | 60.8 | 2.4 |
| Total | | | 60.8 |

^a Weight fraction x Total VOC emitted (lb/yr) = Emissions, lb/yr

Example 2 - Chemical Mixture in a Horizontal Fixed Roof Tank

Assuming that the tank mentioned in Example 1 is now horizontal, calculate emissions. (Tank diameter is 6 ft and length is 12 ft.)

Example 2 Solution:

Emissions from horizontal tanks can be calculated by adjusting parameters in the fixed roof equations. Specifically, an effective diameter, D_E , is used in place of the tank diameter, D . The vapor space height, H_{VO} , is assumed to be half the actual tank diameter.

1. Horizontal tank adjustments. Make adjustments to horizontal tank values so that fixed roof tank equations can be used. The effective diameter, D_E , is calculated as follows:

$$D_E = \sqrt{\frac{LD}{\pi/4}}$$

$$D_E = \sqrt{\frac{12 \cdot 6}{\pi/4}} = 9.57 \text{ ft}$$

The vapor space height, H_{VO} is calculated as follows:

H_{VO} = vapor space outage, ft; use $H_{Eh}/2$ from Equation 1-15 for horizontal tanks

$$H_{Eh} = \frac{\pi}{4} D \quad (1-15)$$

where:

H_{Eh} = effective height of the horizontal tank, ft
 D = diameter of a vertical cross-section of the horizontal tank, ft
 H_{VO} = $(\pi/4) D / 2$
= 2.36 ft

2. Calculate vapor density, W_V :

$$W_V = \frac{M_V P_{VA}}{R T_V} \quad (1-24)$$

where:

R = ideal gas constant = 10.731 psia ft³ / lb-mole °R
 M_V = stock vapor molecular weight, lb/lb-mole
 P_{VA} = stock vapor pressure at the average daily liquid surface temperature T_{LA} , psia
 T_V = average vapor temperature, °R

First, calculate T_{LA} using Equation 1-30.

$$T_{LA} = 0.4 T_{AA} + 0.6 T_B + 0.005 \alpha I \quad (1-30)$$

where:

T_{AA} = average daily ambient temperature, °R

T_B = liquid bulk temperature, °R

I = average daily total insolation, Btu/ft²•d = 1,491 (see Table 7.1-7)

α = tank surface solar absorptance = 0.25 (see Table 7.1-6, for white paint in average condition)

T_{AA} and T_B must be calculated from Equations 1-32 and 1-33.

$$T_{AA} = \frac{T_{AX} + T_{AN}}{2} \quad (1-32)$$

from Table 7.1-7, for Denver, Colorado:

T_{AX} = average daily maximum ambient temperature = 63.5 °F

T_{AN} = average daily minimum ambient temperature = 37.9 °F

Converting to °R:

$T_{AX} = 63.5 + 459.67 = 523.2$ °R

$T_{AN} = 37.9 + 459.67 = 497.6$ °R

Therefore,

$T_{AA} = (523.2 + 497.6)/2 = 510.37$ °R

$$T_B = \text{liquid bulk temperature} = T_{AA} + 0.003 \alpha I \quad (1-33)$$

α = surface solar absorptance = 0.58 (see Table 7.1-6)

I = average daily total insolation on a horizontal surface = 1,491 Btu/ft²•d (see Table 7.1-7)

Substituting values in Equation 1-33

$$T_B = 510.37 + 0.003 (0.58) 1,491 = 512.96$$
 °R

Substituting values into Equation 1-30 above, the average daily liquid surface temperature is calculated:

$$T_{LA} = (0.4) 510.37^\circ\text{R} + 0.6 (512.96^\circ\text{R}) + 0.005 (0.58) (1,491) = 516.25$$
 °R

Second, calculate P_{VA} using Raoult's Law.

According to Raoult's Law, the partial pressure of a component is the product of its pure vapor pressure and its liquid mole fraction. The total vapor pressure of the component mixture stock is equal to the sum of the partial pressures of its components.

The pure vapor pressures for benzene, toluene, and cyclohexane can be calculated from Antoine's equation.

$$\log P_{VA} = A - \left(\frac{B}{T_{LA} + C} \right) \quad (1-28)$$

where:

$\log = \log 10$

A = constant in vapor pressure equation, dimensionless

B = constant in vapor pressure equation, °C

C = constant in vapor pressure equation, °C

T_{LA} = average daily liquid surface temperature, °C

P_{VA} = vapor pressure at average daily liquid surface temperature, mm Hg

Table 7.1-3 provides the Antoine's coefficients for benzene, which are $A = 6.906$, $B = 1,211.0$, and $C = 220.79$. For toluene, $A = 7.017$, $B = 1,377.6$, and $C = 222.64$. For cyclohexane, $A = 6.845$, $B = 1,203.5$, and $C = 222.86$.

$$T_{LA}, \text{ average liquid surface temperature } (^\circ\text{C}) = (516.25 - 491.67)/1.8 = 13.64$$

Therefore, for benzene,

$$\log P = 6.906 - \frac{1,211.0}{(13.64 + 220.79)}$$

$P = 55.03 \text{ mmHg} = 1.064 \text{ psia}$ for benzene

Similarly, for toluene and cyclohexane:

$P = 0.298 \text{ psia}$ for toluene

$P = 1.104 \text{ psia}$ for cyclohexane

In order to calculate the mixture vapor pressure, the partial pressures need to be calculated for each component. The partial pressure is the product of the pure vapor pressures of each component (calculated above) and the mole fractions of each component in the liquid.

The number of moles of the component multiplied by the molecular weight, M_i , of the component equals the amount of each component. Therefore, the number of moles equals the amount of each component divided by the molecular weight. The liquid mole fraction of each component is the number of moles of each component divided by the total moles.

Using the information above, the moles and mole fractions of each component are shown below:

| Component | Amount, lb | M_i | Moles | x_i |
|-------------|------------|-------|-------|-------|
| Benzene | 2,812 | 78.11 | 36.0 | 0.90 |
| Toluene | 258 | 92.14 | 2.80 | 0.07 |
| Cyclohexane | 101 | 84.16 | 1.20 | 0.03 |
| Total | | | 40.0 | 1.00 |

where:

M_i = molecular weight of component

x_i = liquid mole fraction

For example:

The moles of benzene in the liquid is $2,812 / 78.11 = 36.0$

The mole fraction of benzene in the liquid is $36.0 / 40.0 = 0.90$.

The partial pressures of the components can then be calculated as follows:

$$P_i = (P)(x_i) \quad (40-3)$$

where:

P_i = partial pressure of component i, psia

P = vapor pressure of pure component i at the average daily liquid surface temperature, psia

x_i = liquid mole fraction, lb-mole/lb-mole

| Component | P at 516.25°R | x_i | P_i |
|-------------|---------------|-------|-------|
| Benzene | 1.064 | 0.90 | 0.958 |
| Toluene | 0.298 | 0.07 | 0.021 |
| Cyclohexane | 1.104 | 0.03 | 0.033 |
| Total | | 1.0 | 1.012 |

The vapor pressure of the mixture is then 1.012 psia.

Third, calculate the molecular weight of the vapor, M_v . Molecular weight of the vapor depends upon the mole fractions of the components in the vapor.

$$M_v = \sum M_i y_i$$

where:

M_i = molecular weight of the component

y_i = vapor mole fraction

The vapor mole fractions, y_i , are equal to the partial pressure of the component divided by the total vapor pressure of the mixture.

Therefore,

$$y_{\text{benzene}} = P_{\text{partial}}/P_{\text{total}} = 0.958/1.012 = 0.9466$$

Similarly, for toluene and cyclohexane,

$$y_{\text{toluene}} = P_{\text{partial}}/P_{\text{total}} = 0.0208$$

$$y_{\text{cyclohexane}} = P_{\text{partial}}/P_{\text{total}} = 0.0326$$

The mole fractions of the vapor components sum to 1.0.

The molecular weight of the vapor depends upon the mole fractions of the components in the vapor.

$$M_v = \sum M_i y_i$$

where:

M_i = molecular weight of the component

y_i = vapor mole fraction

The values for each component are shown below:

| Component | M_i | y_i | M_v |
|-------------|-------|--------|-------|
| Benzene | 78.11 | 0.9466 | 73.9 |
| Toluene | 92.14 | 0.0208 | 1.92 |
| Cyclohexane | 84.16 | 0.0326 | 2.74 |
| Total | | 1.0 | 78.6 |

Now calculate T_v using Equation 1-35.

$$T_v = 0.7T_{AA} + 0.3T_B + 0.009 \alpha I \quad (1-35)$$

$$T_v = 0.7 (510.37) + 0.3 (512.96) + 0.009 (0.58) (1,491)$$

$$T_v = 518.93 \text{ } ^\circ\text{R}$$

Since all variables have now been solved, the stock density, W_v , can be calculated:

$$W_v = \frac{M_v P_{VA}}{R T_v} \quad (1-24)$$

where:

R = ideal gas constant = 10.731 psia ft³ / lb-mole °R

M_v = stock vapor molecular weight, lb/lb-mole

P_{VA} = stock vapor pressure at the average daily liquid surface temperature T_{LA} , psia

T_v = average vapor temperature, °R

$$W_v = \frac{(78.6)(1.012)}{(10.731)(518.93)} = 0.0143$$

3. Vapor space expansion factor, K_E :

$$K_E = \frac{\Delta T_v}{T_{LA}} + \frac{\Delta P_v - \Delta P_B}{P_A - P_{VA}} \quad (1-5)$$

where:

ΔT_v = average daily vapor temperature range, °R

- ΔP_V = average daily vapor pressure range, °R
- ΔP_B = breather vent pressure setting range, psia
- P_A = atmospheric pressure, 12.08 psia for Denver, Colorado
- P_{VA} = vapor pressure at average daily liquid surface temperature, psia = 1.012 psia (from Step 2)
- T_{LA} = average daily liquid surface temperature, °R = 516.25°R (from Step 2)

First, calculate the average daily vapor temperature range from Equation 1-7:

$$\Delta T_V = 0.7 \Delta T_A + 0.02 \alpha I \quad (1-7)$$

where:

- ΔT_V = average daily vapor temperature range, °R
- ΔT_A = average daily ambient temperature range
- = $T_{AX} - T_{AN}$

where

- T_{AX} = average daily maximum ambient temperature
- T_{AN} = average daily minimum ambient temperature
- T_{AX} = average daily maximum ambient temperature
- T_{AN} = average daily minimum ambient temperature
- α = tank surface solar absorptance, 0.58 (given)
- I = average daily total insolation, 1,491 Btu/ft²•d (given)

from Table 7.1-7, for Denver, Colorado:

- $T_{AX} = 63.5^\circ\text{F}$
- $T_{AN} = 37.9^\circ\text{F}$

Convert to °R by adding 459.67 to the temperature in °F,

- $T_{AX} = 63.5 + 459.67 = 523.2^\circ\text{R}$
- $T_{AN} = 37.9 + 459.67 = 497.6^\circ\text{R}$

From Equation 1-11: $\Delta T_A = T_{AX} - T_{AN}$

$$\Delta T_A = 523.2 - 497.6 = 25.6^\circ\text{R}$$

Therefore,

$$\Delta T_V = 0.7 (25.6) + (0.02)(0.58) (1,491) = 35.22^\circ\text{R}$$

Second, calculate the average daily vapor pressure range using Equation 1-9:

$$\Delta P_V = P_{VX} - P_{VN} \quad (1-9)$$

- P_{VX}, P_{VN} = vapor pressures at the average daily maximum, minimum liquid temperatures can be calculated in a manner similar to the P_{VA} calculation shown earlier.
- T_{LX} = maximum liquid temperature, $T_{LA} + 0.25 \Delta T_V$ (from Figure 7.1-17)

$$\begin{aligned}
T_{LN} &= \text{minimum liquid temperature, } T_{LA} - 0.25 \Delta T_V \text{ (from Figure 7.1-17)} \\
T_{LA} &= 516.25 \text{ (from Step 2)} \\
\Delta T_V &= 35.22^\circ\text{R} \\
T_{LX} &= 516.25 + (0.25) (35.22) = 525.05^\circ\text{R or } 65.38^\circ\text{F} \\
T_{LN} &= 516.25 - (0.25) (35.22) = 507.45^\circ\text{R or } 47.78^\circ\text{F}
\end{aligned}$$

The vapor pressure at P_{VN} for benzene, toluene, and cyclohexane can be calculated from Antoine's equation.

$$\log P_{VN} = A - \left(\frac{B}{T_{LN} + C} \right) \quad (1-28)$$

where:

- log = log 10
- A = constant in vapor pressure equation, dimensionless
- B = constant in vapor pressure equation, °C
- C = constant in vapor pressure equation, °C
- T_{LN} = minimum liquid temperature, °C
- P_{VN} = vapor pressure at minimum liquid temperature, mm Hg

Using Antoine's equation, the pure vapor pressures of each component at the minimum liquid surface temperature ($T_{LN}=507.45^\circ\text{R}$) are:

$$\begin{aligned}
P_{\text{benzene}} &= 0.826 \text{ psia} \\
P_{\text{toluene}} &= 0.224 \text{ psia} \\
P_{\text{cyclohexane}} &= 0.862 \text{ psia}
\end{aligned}$$

The partial pressures of the components can then be calculated as follows:

$$P_i = (P)(x_i) \quad (40-3)$$

where:

- P_i = partial pressure of component i, psia
- P = vapor pressure of pure component i at 507.45°R , psia
- x_i = liquid mole fraction, lb-mole/lb-mole

| Component | P at 507.45°R | x_i | P_i |
|-------------|-----------------------------|-------|-------|
| Benzene | 0.826 | 0.90 | 0.743 |
| Toluene | 0.224 | 0.07 | 0.016 |
| Cyclohexane | 0.862 | 0.03 | 0.026 |
| Total | | 1.0 | 0.785 |

The vapor pressure at P_{VN} for benzene, toluene, and cyclohexane can be calculated from Antoine's equation.

$$\log P_{VX} = A - \left(\frac{B}{T_{LX} + C} \right) \quad (1-28)$$

where:

log = log 10

A = constant in vapor pressure equation, dimensionless

B = constant in vapor pressure equation, °C

C = constant in vapor pressure equation, °C

T_{LX} = maximum liquid temperature, °C

P_{VX} = vapor pressure at maximum liquid temperature, mm Hg

Using Antoine's equation, the pure vapor pressures of each component at the maximum liquid surface temperature (T_{LX}=525.05°R) are:

P_{benzene} = 1.357 psia

P_{toluene} = 0.391 psia

P_{cyclohexane} = 1.400 psia

The partial pressures of the components at T_{LX} can then be calculated as follows:

$$P_i = (P)(x_i) \quad (40-3)$$

where:

P_i = partial pressure of component i, psia

P = vapor pressure of pure component i at 525.05°R, psia

x_i = liquid mole fraction, lb-mole/lb-mole

| Component | P at 525.05°R | x _i | P _i |
|-------------|---------------|----------------|----------------|
| Benzene | 1.357 | 0.90 | 1.221 |
| Toluene | 0.391 | 0.07 | 0.027 |
| Cyclohexane | 1.400 | 0.03 | 0.042 |
| Total | | 1.0 | 1.29 |

Therefore, the vapor pressure range, $\Delta P_V = P_{LX} - P_{LN} = 1.29 - 0.785 = 0.505$ psia.

Next, calculate the breather vent pressure, ΔP_B , from Equation 1-10:

$$\Delta P_B = P_{BP} - P_{BV} \quad (1-10)$$

where:

P_{BP} = breather vent pressure setting = 0.03 psia (given)

P_{BV} = breather vent vacuum setting = -0.03 psig (given)

$\Delta P_B = 0.03 - (-0.03) = 0.06$ psig

Finally, K_E , can be calculated by substituting values into Equation 1-5.

$$K_E = \frac{\Delta T_V}{T_{LA}} + \frac{\Delta P_V - \Delta P_B}{P_A - P_{VA}} \quad (1-5)$$

where:

ΔT_V = average daily vapor temperature range, 35.22°R

ΔP_V = average daily vapor pressure range, 0.505 psia

ΔP_B = breather vent pressure setting range, 0.06 psig

P_A = atmospheric pressure, 12.08 psia for Denver, Colorado

P_{VA} = vapor pressure at average daily liquid surface temperature, psia = 1.012 psia (from Step 2)

T_{LA} = average daily liquid surface temperature, °R = 516.25°R (from Step 2)

$$K_E = \frac{35.22}{516.25} + \frac{(0.505 - 0.06)}{(12.08 - 1.012)} = 0.108$$

4. Given the above adjustments, the standing loss, L_S , can be calculated.

Calculate values for each effected variable in the standing loss equation.

$$L_S = 365 V_V W_V K_E K_S$$

V_V and K_S depend on the effective tank diameter, D_E , and vapor space height, H_{VO} .

These variables can be calculated using the values derived in Step 1 and Step 2:

$D_E = 9.57$ ft

$H_{VO} = 2.36$ ft

$P_{VA} = 1.012$ psia

$$V_V = \frac{\pi}{4} (D_E)^2 H_{VO}$$

$$V_V = \frac{\pi}{4} (9.57)^2 (2.36) = 169.6 \text{ ft}^3$$

$$K_S = \frac{1}{1 + (0.053) (P_{VA}) (H_{VO})}$$

$$K_S = \frac{1}{1 + 0.053(1.012)(2.36)} = 0.888$$

5. Calculate standing loss using the values calculated in Step 2.

$$L_S = 365 V_V W_V K_E K_S$$

$$V_V = 169.6 \text{ ft}^3 \text{ (from Step 2)}$$

$$W_V = 0.0143 \text{ lb/ft}^3 \text{ (from Step 2)}$$

$$K_E = 0.108 \text{ (from Step 3)}$$

$$K_S = 0.888 \text{ (from Step 4)}$$

$$L_S = (365)(0.0143)(169.6)(0.108)(0.888)$$

$$L_S = 85 \text{ lb/yr}$$

6. Calculate working loss.

$$L_W = V_Q K_N K_P W_V K_B \quad (1-37)$$

where:

$$V_Q = 5.614 Q \text{ (when } \Sigma H_{QI} \text{ is unknown; equation 1-41)}$$

$$Q = 8,450 \text{ gal/yr} / 42 \text{ bbl/gal} = 201.2 \text{ bbl/yr (given)}$$

$$V_Q = 5.614 (201.2) \text{ ft}^3/\text{yr}$$

$$K_N = 1 \text{ for turnovers } N \leq 36 \text{ (given)}$$

$$K_P = \text{product factor, dimensionless} = 0.75 \text{ for crude oils, } 1.0 \text{ for all other stocks}$$

$$N = \text{turnovers per year}$$

$$N = \Sigma H_{QI} / (H_{LX} - H_{LN}) \quad (1-38)$$

$$\Sigma H_{QI} = (5.614 Q) / ((\pi/4) D^2) \quad (1-39)$$

$$\Sigma H_{QI} = (5.614) (201.2) / ((\pi/4) 6^2) = 39.9 \text{ ft}$$

$$H_{LX} = 11.5 \text{ ft (given)}$$

$$H_{LN} = 4.5 \text{ ft (given)}$$

$$N = 39.9 / (11.5 - 4.5) = 5.7$$

$$W_V = 0.0143 \text{ lb/ft}^3 \text{ (from Step 2)}$$

$$K_B = 1 \text{ for vent settings of } +/- 0.03 \text{ psig (from Equation 1-37)}$$

$$L_W = (5.614) * (201.2) * (1) * (1) * (0.0143) (1) = 16.1 \text{ lb/yr}$$

$$L_W = 16.1 \text{ lb/yr}$$

7. Calculate total emissions.

$$L_T = L_S + L_W$$

$$L_T = 85 + 16.1 = 101.3 \text{ lb/yr}$$

8. Calculate the amount of each component emitted from the tank (see Step 2).

| Component | No. of Moles ^a | M _i ^a | Pounds _i ^a | Weight fraction |
|-------------|---------------------------|-----------------------------|----------------------------------|-----------------|
| Benzene | (0.9466 x 100) = 94.66 | 78.11 | 7,394 | 0.941 |
| Toluene | (0.0208 x 100) = 2.08 | 92.14 | 192 | 0.024 |
| Cyclohexane | (0.0326 x 100) = 3.26 | 84.16 | 274 | 0.035 |
| Total | 100 | | 7,860 | 1.0 |

^a No. of moles x M_i = Pounds_i

The amount of each component emitted is then calculated as:

$$\text{Emissions of component}_i = (\text{weight fraction}_i)(L_T)$$

| Component | Weight fraction | Total VOC emitted, lb/yr | Emissions, lb/yr |
|-------------|-----------------|--------------------------|------------------|
| Benzene | 0.941 | 101.3 | 95.32 |
| Toluene | 0.024 | 101.3 | 2.43 |
| Cyclohexane | 0.035 | 101.3 | 3.54 |
| Total | | | 101.3 |

^a Weight fraction x Total VOC emitted (lb/yr) = Emissions, lb/yr

Example 3 - Chemical Mixture in an External Floating Roof Tank

Determine the yearly emission rate of a mixture that is 75 percent benzene, 15 percent toluene, and 10 percent cyclohexane, by weight, from a 100,000-gallon external floating roof tank with a pontoon roof. The tank is 20 feet in diameter. The tank has 10 turnovers per year. The tank has a mechanical shoe seal (primary seal) and a shoe-mounted secondary seal. The tank is made of welded steel and has a light rust covering the inside surface of the shell. The tank shell is painted white, and the tank is located in Newark, New Jersey. The floating deck is equipped with the following fittings: (1) an ungasketed access hatch with an unbolted cover, (2) an unspecified number of ungasketed vacuum breakers with weighted mechanical actuation, and (3) ungasketed gauge hatch/sample ports with weighted mechanical actuation.

Example 3 Solution:

1. Determine tank type. The tank is an external floating roof storage tank.
2. Determine estimating methodology. The product consists of three organic liquids, all of which are miscible in each other, which make a homogenous mixture if the material is well mixed. The tank emission rate will be based upon the properties of the mixture. Because the components have similar structures and molecular weights, Raoult's Law is assumed to apply to the mixture.
3. Select equations to be used. For an external floating roof tank,

$$L_T = L_S + L_W \quad (2-1)$$

$$L_S = L_R + L_F + L_D \quad (2-2)$$

$$L_W = (0.943) Q C_S W_L / D \quad (2-19)$$

$$L_R = (K_{Ra} + K_{Rb} V^n) P^* D M_V K_C \quad (2-3)$$

$$L_F = F_F P^* M_V K_C \quad (2-13)$$

$$L_D = K_D S_D D^2 P^* M_V K_C \quad (2-18)$$

where:

L_T = total loss, lb/yr

L_W = working (withdrawal) loss, lb/yr

L_R = rim seal loss from external floating roof tanks, lb/yr

L_F = deck fitting loss, lb/yr

L_D = deck seam loss, lb/yr = 0 for external floating roof tanks

Q = product average throughput, bbl/yr

C_S = product withdrawal shell clingage factor, bbl/1,000 ft²; see Table 7.1-10

W_L = density of liquid, lb/gal

D = tank diameter, ft

- H= shell height, ft
- K_{Ra} = zero wind speed rim seal loss factor, lb-mole/ft•yr; see Table 7.1.8
- K_{Rb} = wind speed dependent rim seal loss factor, lb-mole/(mph)ⁿft•yr; see Table 7.1-8
- v = average ambient wind speed for the tank site, mph
- n = seal wind speed exponent, dimensionless
- K_D = deck seam loss per unit seam length factor, lb-mole/ft/yr
- S_D = deck seam length factor, ft/ft²

Volume of tank = $\pi * \text{radius}^2 * h$
 (100,000 gallons / 7.48 gallons/ft³) = $\pi * (D/2)^2 * h$
 13,368.98 ft³ = $\pi * (20/2)^2 * h$
 13,368.98 ft³ = $\pi * (10)^2 * h$
 $h = 13,368.98 \text{ ft}^3 / (\pi * (36)^2)$
 $h = 42.55 \text{ ft}$

P^* = the vapor pressure function, dimensionless

$$P^* = \frac{\frac{P_{VA}}{P_A}}{\left(1 + \left[1 - \left(\frac{P_{VA}}{P_A}\right)\right]^{0.5}\right)^2}$$

where:

- P_{VA} = the true vapor pressure of the materials stored, psia
- P_A = atmospheric pressure, psia = 14.69 psia from Table 7.1-7 for Newark, New Jersey
- M_V = molecular weight of product vapor, lb/lb-mole
- K_C = product factor, dimensionless
- F_F = the total deck fitting loss factor, lb-mole/yr

$$= \sum_{i=1}^{n_f} (N_{F_i} K_{F_i}) = \left[(N_{F_1} K_{F_1}) + (N_{F_2} K_{F_2}) + \dots + (N_{F_{n_f}} K_{F_{n_f}}) \right]$$

where:

- N_{F_i} = number of fittings of a particular type, dimensionless. N_{F_i} is determined for the specific tank or estimated from Tables 7.1-12, 7.1-13, or 7.1-14
- K_{F_i} = deck fitting loss factor for a particular type of fitting, lb-mole/yr. K_{F_i} is determined for each fitting type from Equation 2-15 and the loss factors in Table 7.1-12
- n_f = number of different types of fittings, dimensionless; $n_f = 3$ (given)

4. Identify parameters to be calculated/determined from tables. In this example, the following parameters are not specified: W_L , F_F , C , K_{Ra} , K_{Rb} , v , n , P_{VA} , P^* , M_V , and K_C . The following values are obtained from tables or assumptions:

- K_C = 1.0 for all stocks other than crude oil (given in Section 7.1.3.2)
- C = 0.0015 bbl/1,000 ft² for tanks with light rust (from Table 7.1-10)

$$K_{Ra} = 1.6 \text{ (from Table 7.1-8)}$$

$$K_{Rb} = 0.3 \text{ (from Table 7.1-8)}$$

$$n = 1.6 \text{ (from Table 7.1-8)}$$

The wind speed for Newark, New Jersey is:

$$v = 9.8 \text{ mph (see Table 7.1-7)}$$

F_F , W_L , P_{VA} , P^* , and M_V still need to be calculated.

F_F is estimated by calculating the individual K_{Fi} and N_{Fi} for each of the three types of deck fittings used in this example. For the ungasketed access hatches with unbolted covers, the K_F value can be calculated using information from Table 7.1-12. For this fitting, $K_{Fa} = 36$, $K_{Fb} = 5.9$, and $m = 1.2$. The value for K_V for external floating roof tanks is 0.7 (see Section 7.1.3, Equation 2-15). There is normally one access hatch. So,

$$K_{F_{\text{access hatch}}} = K_{Fa} + K_{Fb}(K_V v)^m = 36 + 5.9 [(0.7)(9.8)]^{1.2}$$

$$K_{F_{\text{access hatch}}} = 95.5 \text{ lb-mole/yr}$$

$$N_{F_{\text{access hatch}}} = 1$$

The number of vacuum breakers can be taken from Table 7.1-13. For a tank with a diameter of 20 feet and a pontoon roof, the typical number of vacuum breakers is one. Table 7.1-12 provides fitting factors for weighted mechanical actuation, ungasketed vacuum breakers when the average wind speed is 10.3 mph.

Based on this table, $K_{Fa} = 7.8$, $K_{Fb} = 0.01$, and $m = 4$. So,

$$K_{F_{\text{vacuum breaker}}} = K_{Fa} + K_{Fb} (K_V v)^m$$

$$K_{F_{\text{vacuum breaker}}} = 7.8 + 0.01 [(0.7)(9.8)]^4$$

$$K_{F_{\text{vacuum breaker}}} = 29.9 \text{ lb-mole/yr}$$

$$N_{F_{\text{vacuum breaker}}} = 1$$

For the ungasketed gauge hatch/sample ports with weighted mechanical actuation, Table 7.1-12 indicates that floating roof tanks normally have only one. This table also indicates that $K_{Fa} = 2.3$, $K_{Fb} = 0$, and $m = 0$. Therefore,

$$K_{F_{\text{gauge hatch/sample port}}} = K_{Fa} + K_{Fb} (K_V v)^m$$

$$K_{F_{\text{gauge hatch/sample port}}} = 2.3 + 0$$

$$K_{F_{\text{gauge hatch/sample port}}} = 2.3 \text{ lb-mole/yr}$$

$$N_{F_{\text{gauge hatch/sample port}}} = 1$$

F_F can be calculated from Equation 2-14:

$$F_F = \sum_{i=1}^3 (K_{Fi}) (N_{Fi})$$

where:

N_{Fi} = number of deck fittings of a particular type ($i = 3$), dimensionless

K_{Fi} = deck fitting loss factor for a particular type ($i = 3$) fitting, lb-mole/yr

$$= (95.5)(1) + (29.9)(1) + (2.3)(1)$$

$$= 127.7 \text{ lb-mole/yr}$$

5. Calculate mole fractions in the liquid. The mole fractions of components in the liquid must be calculated in order to estimate the vapor pressure of the liquid using Raoult's Law. For this example, the weight fractions (given as 75 percent benzene, 15 percent toluene, and 10 percent cyclohexane) of the mixture must be converted to mole fractions. First, assume that there are 1,000 lb of liquid mixture. Using this assumption, the mole fractions calculated will be valid no matter how many pounds of liquid actually are present. The corresponding amount (pounds) of each component is equal to the product of the weight fraction and the assumed total pounds of mixture of 1,000. The number of moles of each component is calculated by dividing the weight of each component by the molecular weight of the component. The mole fraction of each component is equal to the number of moles of each component divided by the total number of moles.

Using the information in the preceding paragraph, the following values are calculated:

| Component | Weight fraction | Weight, lb | Molecular weight, M_i , lb/lb-mole | Moles | Mole fraction |
|-------------|-----------------|------------|--------------------------------------|--------|---------------|
| Benzene | 0.75 | 750 | 78.11 | 9.603 | 0.773 |
| Toluene | 0.15 | 150 | 92.14 | 1.629 | 0.131 |
| Cyclohexane | 0.10 | 100 | 84.16 | 1.188 | 0.096 |
| Total | 1.00 | 1,000 | | 12.420 | 1.000 |

For example:

The moles of benzene in the liquid is $750 / 78.11 = 9.603$.

The mole fraction of benzene in the liquid is $9.603/12.420 = 0.773$.

6. Determine the average daily liquid surface temperature. The average daily liquid surface temperature is equal to:

$$T_{LA} = 0.7 T_{AA} + 0.3 T_B + 0.008 \alpha_R I$$

where:

$$T_{AA} = (T_{AX} + T_{AN})/2$$

$$T_B = T_{AA} + [0.71 \alpha_R I + 0.485 (H_z/D) \alpha_S I] / (170 H_z/D + 57)$$

For Newark, New Jersey (see Table 7.1-7):

$$T_{AX} = 63.1^\circ\text{F} + 459.67 = 522.77^\circ\text{R}$$

$$T_{AN} = 47.6^\circ\text{F} + 459.67 = 507.27^\circ\text{R}$$

$$I = 1,226 \text{ Btu/ft}^2 \cdot \text{d}$$

From Table 7.1-6, $\alpha_R = 0.25$ and $\alpha_S = 0.25$

Therefore;

$$T_{AA} = (522.77 + 507.27)/2 = 515.02^\circ\text{R}$$

$$T_B = 515.02 + [0.71 \cdot 0.25 \cdot 1226 + 0.485 \cdot 42.55/20 \cdot 0.25 \cdot 1226] / (170 \cdot 42.55/20 + 57)$$

$$T_B = 515.02 + [217.62 + 316.26]/(418.675) = 516.30^\circ\text{R}$$

$$T_{LA} = 0.7 (515.02) + 0.3 (516.30) + 0.008 (0.25)(1226)$$

$$= 517.86^{\circ}\text{R} = 58.18^{\circ}\text{F}$$

7. Calculate partial pressures and total vapor pressure of the liquid. The vapor pressure of each component at 58.18°F can be determined using Antoine's equation. Since Raoult's Law is assumed to apply in this example, the partial pressure of each component is the liquid mole fraction (x_i) times the vapor pressure of the component (P).

| Component | P at 58.18°F | x_i | P_{partial} |
|-------------|--------------|-------|----------------------|
| Benzene | 1.11 | 0.773 | 0.861 |
| Toluene | 0.31 | 0.131 | 0.041 |
| Cyclohexane | 1.15 | 0.096 | 0.110 |
| Totals | | 1.00 | 1.012 |

The total vapor pressure of the mixture is estimated to be 1.012 psia.

8. Calculate mole fractions in the vapor. The mole fractions of the components in the vapor phase are based upon the partial pressure that each component exerts (calculated in Step 7).

So for benzene:

$$y_{\text{benzene}} = P_{\text{partial}}/P_{\text{total}} = 0.861/1.012 = 0.851$$

where:

- y_{benzene} = mole fraction of benzene in the vapor
- P_{partial} = partial pressure of benzene in the vapor, psia
- P_{total} = total vapor pressure of the mixture, psia

Similarly,

$$y_{\text{toluene}} = 0.041/1.012 = 0.040$$

$$y_{\text{cyclohexane}} = 0.110/1.012 = 0.109$$

The vapor phase mole fractions sum to 1.0.

9. Calculate molecular weight of the vapor. The molecular weight of the vapor depends upon the mole fractions of the components in the vapor.

$$M_v = \sum M_i y_i$$

where:

- M_v = molecular weight of the vapor, lb/lb-mole
- M_i = molecular weight of component i, lb/lb-mole
- y_i = mole fraction of component i in the vapor, lb-mole/lb-mole

| Component | M_i | y_i | $M_v = \sum(M_i)(y_i)$ |
|-------------|-------|-------|------------------------|
| Benzene | 78.11 | 0.851 | 66.47 |
| Toluene | 92.14 | 0.040 | 3.69 |
| Cyclohexane | 84.16 | 0.109 | 9.17 |
| Total | | 1.00 | 79.33 |

The molecular weight of the vapor is 79.33 lb/lb-mole.

10. Calculate weight fractions of the vapor. The weight fractions of the vapor are needed to calculate the amount (in pounds) of each component emitted from the tank. The weight fractions are related to the mole fractions calculated in Step 7 and total molecular weight calculated in Step 9:

$$Z_{Vi} = \frac{y_i M_i}{M_v}$$

$$Z_{Vi} = (0.851) * (78.11) / 79.33 = 0.838 \text{ for benzene}$$

$$Z_{Vi} = (0.040) * (92.14) / 79.33 = 0.046 \text{ for toluene}$$

$$Z_{Vi} = (0.109) * (84.16) / 79.33 = 0.116 \text{ for cyclohexane}$$

11. Calculate total VOC emitted from the tank. The total VOC emitted from the tank is calculated using the equations identified in Step 3 and the parameters calculated in Steps 4 through 9.

$$L_T = L_W + L_S$$

$$L_S = L_R + L_F$$

a. Calculate working (withdrawal) losses:

$$L_W = 0.943 \text{ QCW}_L / D$$

where:

$$Q = 100,000 \text{ gal} \times 10 \text{ turnovers/yr (given)}$$

$$= 1,000,000 \text{ gal} \times 1 \text{ bbl}/42 \text{ gal} = 23,809.5 \text{ bbl/yr}$$

$$C = 0.0015 \text{ bbl}/10^3 \text{ ft}^2 \text{ (from Table 7.1-10)}$$

$$W_L = 1 / [\Sigma (\text{wt fraction in liquid}) / (\text{liquid component density from Table 7.1-3})]$$

Weight fractions

Benzene = 0.75 (given)

Toluene = 0.15 (given)

Cyclohexane = 0.10 (given)

Liquid densities

Benzene = 7.32 (see Table 7.1-3)

Toluene = 7.24 (see Table 7.1-3)

Cyclohexane = 6.46 (see Table 7.1-3)

$$W_L = 1 / [(0.75/7.32) + (0.15/7.24) + (0.10/6.46)]$$

$$= 1 / (0.1025 + 0.0207 + 0.0155)$$

$$= 1 / 0.1387$$

$$= 7.2 \text{ lb/gal}$$

$$D = 20 \text{ ft (given)}$$

$$L_W = 0.943 \text{ QCW}_L / D$$

$$= [0.943(23,809.5)(0.0015)(7.2) / 20]$$

$$= 12.1 \text{ lb of VOC/yr from withdrawal losses}$$

b. Calculate rim seal losses:

$$L_R = (K_{Ra} + K_{Rb}v^n)DP^*M_VK_C$$

where:

$$K_{Ra} = 1.6 \text{ (from Step 4)}$$

$$K_{Rb} = 0.3 \text{ (from Step 4)}$$

$$v = 9.8 \text{ mph (from Step 4)}$$

$$n = 1.6 \text{ (from Step 4)}$$

$$K_C = 1 \text{ (from Step 4)}$$

$$P_{VA} = 1.000 \text{ psia (from Step 7) (formula from Step 3)}$$

$$D = 20 \text{ ft}$$

$$M_V = 79.33 \text{ lb/lb-mole (from Step 9)}$$

$$P^* = \frac{\frac{P_{VA}}{P_A}}{\left(1 + \left[1 - \left(\frac{P_{VA}}{P_A}\right)^{0.5}\right]^2\right)}$$

$$= (1.019/14.69)/(1 + [1 - (1.019/14.69)]^{0.5})^2$$

$$= 0.01785$$

$$L_R = [(1.6 + (0.3)(9.8)^{1.6}](0.018)(20)(79.33)(1.0)$$

$$= (13.16)(0.01785)(20)(79.33)(1.0)$$

$$= 372.6 \text{ lb of VOC/yr from rim seal losses}$$

c. Calculate deck fitting losses:

$$L_F = F_F P^* M_V K_C$$

where:

$$F_F = 127.7 \text{ lb-mole/yr (from Step 4)}$$

$$P^* = 0.01785$$

$$M_V = 79.32 \text{ lb/lb-mole}$$

$$K_C = 1.0 \text{ (from Step 4)}$$

$$L_F = (127.7)(0.01785)(79.32)(1.0)$$

$$= 180.8 \text{ lb/yr of VOC emitted from deck fitting losses}$$

d. Calculate total losses:

$$L_T = L_W + L_R + L_F$$

$$= 12.1 + 372.6 + 180.8$$

$$= 565.5 \text{ lb/yr of VOC emitted from tank}$$

12. Calculate amount of each component emitted from the tank. For an external floating roof tank, the individual component losses are determined by Equation 40-2:

$$L_{T_i} = (Z_{V_i})(L_R + L_F) + (Z_{L_i})(L_W)$$

Therefore,

$$L_{T_{benzene}} = (0.838)(372.6+180.8) + (0.75)(12.1) = 472.8 \text{ lb/yr benzene}$$

$$L_{T_{toluene}} = (0.046)(372.6+180.8) + (0.15)(12.1) = 27.3 \text{ lb/yr toluene}$$

$$L_{T_{cyclohexane}} = (0.116)(372.6+180.8) + (0.10)(12.1) = 65.4 \text{ lb/yr cyclohexane}$$

Example 4 - Gasoline in an Internal Floating Roof Tank

Determine emissions of product from a 1 million gallon internal floating roof tank containing gasoline (RVP 13). The tank is painted white and is located in Tulsa, Oklahoma. Product is pumped into and out of the tank simultaneously. The sum of decreases in the liquid level is 1,735 feet. The tank is 70 ft in diameter and 35 ft high and is equipped with a liquid-mounted primary seal plus a secondary seal. The tank has a column-supported fixed roof. The tank's deck is welded and equipped with the following: (1) two access hatches with unbolted, ungasketed covers; (2) an automatic gauge float well with an unbolted, ungasketed cover; (3) a round pipe support column well with a flexible fabric sleeve seal; (4) a sliding cover, gasketed ladder well; (5) adjustable deck legs; (6) a slotted guidepole/sample pipe well with a gasketed sliding cover; and (7) a weighted, gasketed vacuum breaker. The following data are available on the concentrations of air toxics in the liquid phase, by weight:

| Component | Weight Percent In Liquid |
|--------------|--------------------------|
| Benzene | 0.55 |
| Toluene | 7.6 |
| Ethylbenzene | 1.4 |
| Xylenes | 6.9 |

Example 4 Solution:

1. Determine tank type. The following information must be known about the tank in order to use the floating roof equations:

- the number of columns
- the effective column diameter
- the rim seal description (vapor- or liquid-mounted, primary or secondary seal)
- the deck fitting types and the deck seam length

Some of this information depends on specific construction details, which may not be known. In these instances, approximate values are provided for use.

2. Determine estimating methodology. Gasoline consists of many organic compounds, all of which are miscible in each other, which form a homogenous mixture. The tank emission rate will be based on the properties of RVP 13 gasoline. Since Reid vapor pressure is available, Raoult's Law will not be used to determine the true vapor pressure of the liquid (as it was in the prior example), but it will be used to estimate vapor phase fractions of the air toxic components. The molecular weight of gasoline will be taken from a table and will not be calculated.

3. Select equations to be used.

$$L_T = L_S + L_W \quad (2-1)$$

$$L_S = L_R + L_F + L_D \quad (2-2)$$

$$L_W = \left(\frac{(0.943) Q C_S W_L}{D} \right) \left[1 + \left(\frac{N_C F_C}{D} \right) \right] \quad (2-19)$$

$$L_R = (K_{Ra} + K_{Rb} v^n) D P^* M_V K_C \quad (2-3)$$

$$L_F = F_F P^* M_V K_C \quad (2-13)$$

$$L_D = K_D S_D D^2 P^* M_V K_C \quad (2-18)$$

where:

L_T = total loss, lb/yr

L_S = standing loss, lb/yr

L_W = working (withdrawal) loss, lb/yr

L_R = rim seal loss, lb/yr

L_F = deck fitting loss, lb/yr

L_D = deck seam loss, lb/yr

Q = annual net throughput, bbl/yr

C_S = product withdrawal shell clingage factor, bbl/1,000 ft²

W_L = density of liquid, lb/gal

D = tank diameter, ft

N_C = number of fixed roof support columns, dimensionless

F_C = effective column diameter, ft

K_{Ra} = zero wind speed rim seal loss factor, lb-mole/ft•yr

K_{Rb} = wind speed dependent rim seal loss factor, lb-mole/(mph)ⁿft•yr

v = average ambient site wind speed (zero for internal floating roof tanks), mph

M_V = the average molecular weight of the product vapor, lb/lb-mole

K_C = the product factor, dimensionless

P^* = the vapor pressure function, dimensionless

$$P^* = \frac{\frac{P_{VA}}{P_A}}{\left(1 + \left[1 - \left(\frac{P_{VA}}{P_A} \right) \right]^{0.5} \right)^2}$$

P_{VA} = the vapor pressure of the material stored, psia

P_A = average atmospheric pressure at tank location, psia

F_F = the total deck fitting loss factor, lb-mole/yr

$$= \sum_{i=1}^{n_f} (K_{Fi}) (N_{Fi}) = [(N_{F1} K_{F1}) + (N_{F2} K_{F2}) + \dots + (N_{F_{n_f}} K_{F_{n_f}})]$$

- N_{Fi} = number of deck fittings of a particular type, dimensionless. N_{Fi} is determined for the specific tank or estimated from Table 7.1-12
 K_{Fi} = deck fitting loss factor for a particular type of deck fitting, lb-mole/yr. K_{Fi} is determined for each fitting type using Table 7.1-12 and, for an internal floating roof tank, Equation 2-16
 n_f = number of different types of fittings, dimensionless
 K_D = the deck seam loss factor, lb-mole/ft²•yr
 = 0.14 for nonwelded decks
 = 0 for welded decks
 S_D = deck seam length factor, ft/ft²
 = L_{seam}/A_{deck}

where:

- L_{seam} = total length of deck seams, ft
 A_{deck} = area of deck, ft² = $\pi D^2/4$

4. Identify parameters to be calculated or determined from tables. In this example, the following parameters are not specified: W_L , N_C , F_C , C , P_{VA} , M_V , K_{Ra} , v , P^* , K_C , F_F , K_D , S_D , and weight fractions of air toxic components in the vapor.

The wind speed, v , is assumed to be zero for an internal floating roof tank, and thus values are not needed for K_{Rb} and n for the rim seal. Similarly, the deck fitting loss factor K_{Fi} is equal to K_{Fai} , from Equation 2-16.

The following parameters can be obtained from tables or assumptions:

- K_C = 1.0 for all stocks other than crude oil
 N_C = 1 (from Table 7.1-11)
 F_C = 1.0 (assumed)
 K_{Ra} = 0.3 (from Table 7.1-8)
 v = 0 for internal floating roof tanks
 M_V = 62 lb/lb-mole (from Table 7.1-2)
 W_L = 5.6 lb/gal (from Table 7.1-2)
 C = 0.0015 bbl/1,000 ft² (from Table 7.1-10)
 K_D = 0 for welded decks so S_D is not needed
 F_F = $\sum (K_{Fai} N_{Fi})$, where values for K_{Fai} are from Table 7.1-12

5. Calculate mole fractions in the liquid. Mole fractions of the air toxic components in the liquid can be calculated using Raoult's Law. Assume that the properties of m-xylene will suitably represent the component identified as Xylenes. The molecular weight of the liquid stock is given as 92 lb/lb-mole, and thus liquid mole fractions of individual components can be calculated using Equation 40-4.

$$x_i = \frac{Z_{Li} M_L}{M_i}$$

- x_i = (0.0055)*(92) / 78.11 = 0.0065 for benzene
 x_i = (0.076)*(92) / 92.14 = 0.0759 for toluene
 x_i = (0.014)*(92) / 106.17 = 0.0121 for ethylbenzene

$$x_i = (0.069)(92) / 106.17 = 0.0598 \text{ for xylenes}$$

6. Calculate the average daily liquid surface temperature. The average daily liquid surface temperature is equal to:

$$T_{LA} = \frac{[2.86 (H_S/D) + 1.43] T_{AA} + [3.52 (H_S/D) + 3.79] T_B + 0.027 \alpha_R I + 0.017(H_S/D) \alpha_S I}{6.38 (H_S/D) + 5.22}$$

$$T_{AA} = (T_{AX} + T_{AN})/2$$

$$T_B = T_{AA} + 0.003 \alpha I$$

For Tulsa, Oklahoma (see Table 7.1-7):

$$T_{AX} = 70.8^\circ\text{F} = 530.5^\circ\text{R}$$

$$T_{AN} = 51.1^\circ\text{F} = 510.8^\circ\text{R}$$

$$I = 1,407 \text{ Btu/ft}^2 \cdot \text{d}$$

From Table 7.1-6, $\alpha = 0.25$

Therefore,

$$T_{AA} = (530.5 + 510.8)/2 = 520.65^\circ\text{R}$$

$$T_B = 520.65 + 0.003 (0.25) 1,407 = 521.705^\circ\text{R}$$

$$T_{LA} = 0.34 (520.65) + 0.66 (521.705) + 0.0032 (0.25)(1,407) + 0.0010 (0.25)(1,407)$$

$$T_{LA} = 177.021 + 344.325 + 1.1256 + 0.35175$$

$$T_{LA} = 522.82^\circ\text{R} \text{ or } 63.15^\circ\text{F}$$

7. Calculate partial pressures and total vapor pressure of the liquid. The total vapor pressure of gasoline RVP 13 can be calculated from Equation 1-27, using values for the vapor pressure constants A and B from Table 7.1-2.

$$P_{VA} = \exp \left[A - \frac{B}{T_{LA}} \right]$$

$$P_{VA} = \exp \left[11.644 - \frac{5043.6}{63.1 + 459.7} \right]$$

$$P_{VA} = 7.36 \text{ psia at } 63.15^\circ\text{F}$$

From Table 7.1-7, $P_A = 14.36 \text{ psia}$

Therefore,

$$P^* = \frac{\frac{P_{VA}}{P_A}}{\left[1 + \left(1 - \frac{P_{VA}}{P_A} \right)^{0.5} \right]^2}$$

$$P^* = (7.36/14.36)/[1 + (1-(7.36/14.36))^{0.5}]^2$$

$$P^* = 0.178$$

The vapor pressure of each component at 63.15°F can be determined using Antoine's equation. Since Raoult's Law is assumed to apply in this example, the partial pressure of each component is the liquid mole fraction (x_i) times the vapor pressure of the component (P), from Equation 40-3.

For benzene,

$$\log P = 6.906 - (1211.0 / ((522.82 - 491.67) / 1.8 + 220.79)) = 1.8198 \text{ mmHg}$$

$$P = 10^{1.8198} \text{ mmHg}$$

$$P = 66.046 \text{ mmHg} * 14.7 / 760 =$$

$$P = 1.277 \text{ psia}$$

| Component | P at 63.15°F | x _i | P _{partial} |
|--------------|--------------|----------------|----------------------|
| Benzene | 1.277 | 0.0065 | 0.0083 |
| Toluene | 0.365 | 0.0759 | 0.0277 |
| Ethylbenzene | 0.116 | 0.0121 | 0.0014 |
| Xylenes | 0.1008 | 0.0598 | 0.0060 |

8. Calculate mole fractions of components in the vapor. The mole fraction of each component in the vapor phase is the partial pressure of the component (P_{partial}) divided by the total vapor pressure of the mixture (P_{VA}), from Equation 40-3.

$$y_i = P_{\text{partial}} / P_{\text{VA}}$$

$$y_i = 0.0083 / 7.36 = 0.0011 \text{ for benzene}$$

$$y_i = 0.0277 / 7.36 = 0.0038 \text{ for toluene}$$

$$y_i = 0.0014 / 7.36 = 0.0002 \text{ for ethylbenzene}$$

$$y_i = 0.0060 / 7.36 = 0.0008 \text{ for xylenes}$$

9. Calculate molecular weight of the vapor. This step is not required because the molecular weight of gasoline vapor is already specified.

10. Calculate weight fractions of components of the vapor. The weight fraction of each component in the vapor phase can be calculated using Equation 40-6.

$$Z_{vi} = \frac{y_i M_i}{M_v}$$

$$Z_{vi} = (0.0011) * (78.11) / 62 = 0.0014 \text{ for benzene}$$

$$Z_{vi} = (0.0038) * (92.14) / 62 = 0.0056 \text{ for toluene}$$

$$Z_{vi} = (0.0002) * (106.17) / 62 = 0.0003 \text{ for ethylbenzene}$$

$$Z_{vi} = (0.0008) * (106.17) / 62 = 0.0014 \text{ for xylenes}$$

11. Calculate total VOC emitted from the tank. The total VOC emitted from the tank is calculated using the equations identified in Step 3 and the parameters specified in Step 4.

$$L_T = L_W + L_S$$

$$L_S = L_R + L_F + L_D$$

a. Calculate working (withdrawal) losses:

$$L_W = [(0.943)QCW_t] / D [1 + (N_c F_c) / D]$$

where:

$$\begin{aligned}
Q &= (\pi/4) D^2 (\Sigma H_{QD}/5.614) \\
&= (\pi/4) (70)^2 (1,735/5.614) = 1,189,359 \text{ bbl/yr} \\
C &= 0.0015 \text{ bbl}/1,000 \text{ ft}^2 \\
W_L &= 5.6 \text{ lb/gal} \\
D &= 70 \text{ ft} \\
N_C &= 1 \\
F_C &= 1 \\
L_W &= [(0.943)(1,189,359) (0.0015)(5.6)]/70[1 + (1)(1)/70] \\
&= 136.5 \text{ lb/yr VOC for withdrawal losses}
\end{aligned}$$

b. Calculate rim seal losses:

$$L_R = (K_{Ra} + K_{Rb}v^n)DP^*M_VK_C$$

Since $v = 0$ for IFRT's:

$$L_R = K_{Ra}DP^*M_VK_C$$

where:

$$\begin{aligned}
K_{Ra} &= 0.3 \text{ lb-mole}/\text{ft}\cdot\text{yr} \\
D &= 70 \text{ ft} \\
P^* &= 0.178 \\
M_V &= 62 \text{ lb}/\text{lb-mole} \\
K_C &= 1.0 \\
L_R &= (0.3)(0.178)(70)(62)(1.0) = 231.8 \text{ lb/yr VOC from rim seals}
\end{aligned}$$

c. Calculate deck fitting losses:

$$L_F = F_F P^* M_V K_C$$

where:

$$\begin{aligned}
F_F &= \Sigma (K_{Fi} N_{Fi}) \\
K_{Fi} &= K_{Fa_i} \text{ for internal floating roof tanks since the wind speed is zero (see Equation 2-16).}
\end{aligned}$$

The number of deck legs is determined from Table 7.1-15 as follows:

$$\begin{aligned}
N_{fdl} &= (5 + D/10 + D^2/600) \\
N_{fdl} &= (5 + 70/10 + (70)^2/600) \\
N_{fdl} &= 20
\end{aligned}$$

Substituting values for K_{Fa_i} taken from Table 7.1-12 for access hatches, gauge float well, round pipe column well, ladder well, deck legs, sample pipe well, and vacuum breaker, respectively, yields:

$$\begin{aligned}
F_F &= (36)(2) + (14)(1) + (10)(1) + (56)(1) + (7.9)(20) + (43)(1) + (6.2)(1) \\
&= 359 \text{ lb-mole/yr} \\
P^* &= 0.178 \\
M_V &= 62 \text{ lb}/\text{lb-mole} \\
K_C &= 1 \\
L_F &= (359)(0.178)(62)(1.0) = 3,961.9 \text{ lb/yr VOC from deck fittings}
\end{aligned}$$

d. Calculate deck seam losses:

$$L_D = K_D S_D D^2 P^* M_V K_C$$

Since $K_D = 0$ for IFRT's with welded decks,

$$L_D = 0 \text{ lb/yr VOC from deck seams}$$

e. Calculate total losses:

$$\begin{aligned} L_T &= L_W + L_R + L_F + L_D \\ &= 136.5 + 231.8 + 3,961.9 + 0 = 4,330.2 \text{ lb/yr of VOC emitted from the tank} \end{aligned}$$

12. Calculate amount of each component emitted from the tank. The individual component losses are equal to:

$$L_{T_i} = (Z_{V_i})(L_R + L_F + L_D) + (Z_{L_i})(L_W)$$

Therefore,

$$\begin{aligned} L_{T_{\text{benzene}}} &= (0.0014)(4,193.7) + (0.0055)(136.5) = 6.6 \text{ lb/yr benzene} \\ L_{T_{\text{toluene}}} &= (0.0056)(4,193.7) + (0.076)(136.5) = 34 \text{ lb/yr toluene} \\ L_{T_{\text{ethylbenzene}}} &= (0.0003)(4,193.7) + (0.014)(136.5) = 3.2 \text{ lb/yr ethylbenzene} \\ L_{T_{\text{xylenes}}} &= (0.0014)(4,193.7) + (0.069)(136.5) = 15 \text{ lb/yr xylenes} \end{aligned}$$

Example 5 – Floating Roof Landing Loss for an External Floating Roof Tank

Determine emissions of product from the landing of a floating roof in an external floating roof tank containing gasoline during the month of April. The tank is painted white and is located in Port Arthur, Texas. The tank is 120 ft in diameter and 40 ft high and has a nominally flat bottom. The tank has a mechanical shoe seal (primary seal) and a shoe-mounted secondary seal. The tank is made of welded steel and has a light rust covering the inside surface of the shell. The floating deck is equipped with the following fittings: (1) an ungasketed access hatch with an unbolted cover, (2) an unspecified number of ungasketed vacuum breakers with weighted mechanical actuation, and (3) ungasketed gauge hatch/sample ports with weighted mechanical actuation. The floating roof is landed while the tank contains gasoline having an RVP of 12 and is reloaded with gasoline having an RVP of 7.0. For both gasolines, the benzene concentration is known to be 0.5 percent by weight in the liquid. The deck support legs are set at a height of 3 feet, and the liquid is lowered to a level of one foot. The tank is refilled three days after the landing of the floating roof.

Example 5 Solution

1. Determine tank type. The tank is an external floating roof storage tank.
2. Determine estimating methodology. Gasoline consists of many organic compounds, all of which are miscible in each other, which form a homogenous mixture. The molecular weight of gasoline will be taken from a table and the true vapor pressure will be calculated from the Reid vapor pressure of the mixture. Weight fractions of components of interest in the vapor phase will be calculated from concentrations in the liquid phase, using Raoult's Law.
3. Select equations to be used.

$$L_{TL} = L_{SL} + L_{FL} \quad (3-1)$$

$$L_{SLwind} = 0.62 n_d DP^* M_V \leq 5.9 D^2 h_{le} W_L \quad (3-4, 3-8)$$

$$L_{FL} = \left(\frac{P_{VA} V_V}{R T_V} \right) M_V (C_{if} S) \leq (5.9 D^2 h_{le} W_L - L_{SL}) + (0.15 P_{VA} V_V M_V / R T_V) \quad (3-16, 3-18)$$

where:

- L_{TL} = total losses during roof landing, lb
- L_{SL} = standing idle loss during roof landing, lb (= L_{SLwind} for external floating-roof tanks)
- L_{SLwind} = standing idle loss due to wind, lb
- 0.62 = daily rim seal factor; $(K_{Ra} + K_{Rb} v^n)/365$, where $K_{Ra} = 6.7$, $K_{Rb} = 0.2$, $v = 10.3$, and $n = 3.0$
- n_d = number of days that the tank is standing idle, days
- D = tank diameter, ft

- P* = a vapor pressure function, dimensionless
- M_v = stock vapor molecular weight, lb/lb-mole
- 5.9 = combination of constants (π/4) and 7.48 gal/ft³
- h_{le} = effective height of the stock liquid, feet
- W_L = density of the liquid inside the tank, lb/gal
- L_{FL} = filling loss during roof landing, lb
- P_v = true vapor pressure of the liquid inside the tank, psia
- V_v = volume of the vapor space, ft³
- R = ideal gas constant, 10.731 psia ft³ /lb-mole °R
- T_v = average temperature of the vapor and liquid below the floating roof, °R (= T_{AA})
- C_{sf} = filling saturation correction factor for wind, dimensionless
- S = filling saturation factor, dimensionless (0.60 for a full liquid heel; 0.50 for a partial liquid heel).

4. Identify parameters to be calculated/determined from tables. In this example, the following parameters are not specified: P*, M_v, W_L, P_{vA}, V_v, T_v, C_{sf} and S.

The following values are obtained from tables or assumptions:

- M_v = 66 lb/lb-mole, from Table 7.1-2 as a default value for the vapor phase molecular weight of all gasolines.
- W_L = 5.6 lb/gal, from Table 7.1-2 for gasoline.
- T_v = 68.7 °F (528.37°R) from Table 7.1-7, the average ambient temperature (T_{AA}) for April in Port Arthur, TX.
- S = 0.60 for a full liquid heel.

Values for the following parameters still need to be calculated:

- P* = a vapor pressure function, dimensionless. P* is needed to calculate the standing idle loss, which occurs with a heel of gasoline (RVP 12) in the tank.

$$P^* = \frac{\frac{P_v}{P_A}}{\left(1 + \left[1 - \left(\frac{P_v}{P_A}\right)\right]^{0.5}\right)^2}$$

The true vapor pressure, P_v, in the equation for P* is the same as the true vapor pressure, P_v, in the calculation of the landing loss. Typical atmospheric pressure, P_A, for Port Arthur, TX is obtained from Table 7.1-7, as 14.68 psi.

- P_v = true vapor pressure of the liquid inside the tank, psia

Note that the temperature beneath the landed floating roof (given that the tank bottom is in contact with the ground) is assumed to be equal to ground temperature, which is taken as the average ambient temperature for the month in which the landing occurs.

Therefore, T_{LA} is equal to T_{AA} or 528.37°R.

Determine P_v using Equation 1-27, with values for the constants A and B determined from the equations in Figure 7.1-15 using the given Reid vapor pressure and the default value of 3.0 given for the distillation slope S in Table 7.1-2.

$$A = 15.64 - 1.854 S^{0.5} - (0.8742 - 0.3280 S^{0.5}) \ln(\text{RVP})$$

$$B = 8,742 - 1,042 S^{0.5} - (1,049 - 179.4 S^{0.5}) \ln(\text{RVP})$$

For gasoline RVP 12, the calculated values of A, B, P and P* are:

$$A = 11.668$$

$$B = 5102.7$$

$$P_V = 7.47 \text{ psia at } 528.37 \text{ }^\circ\text{R}$$

$$P^* = 0.176$$

For gasoline RVP 7.0, the calculated values of A, B and P_{VA} are:

$$A = 11.833$$

$$B = 5500.6$$

$$P_V = 4.15 \text{ psia at } 528.37 \text{ }^\circ\text{R}$$

V_V = volume of the vapor space, ft³

Determine the vapor space volume V_V using Equation 3-22, where the height of the vapor space under the floating roof is the difference between the floating roof leg height and the depth of the liquid heel, which are given as 3 feet and 1 foot respectively. Thus the height of the vapor space under the floating roof is 2 feet, and the vapor space volume is:

$$V_V = (2) (\pi 120^2/4)$$

$$V_V = 22619 \text{ ft}^3$$

C_{sf} = filling saturation correction factor for wind, dimensionless

$$C_{sf} = 1 - \left(\frac{(0.62 \cdot 1 \cdot D \cdot P^* \cdot M_V) - (1 \cdot K_E \cdot \left(\frac{P_{VA} \cdot V_V}{R \cdot T_V}\right) \cdot M_V \cdot K_S)}{(1 \cdot K_E \cdot \left(\frac{P_{VA} \cdot V_V}{R \cdot T_V}\right) \cdot M_V \cdot K_S) + \left(\frac{P_{VA} \cdot V_V}{R \cdot T_V}\right) \cdot M_V \cdot (1 \cdot S)} \right) \quad (3-21)$$

Solve for K_E:

$$K_E = \frac{\Delta T_V}{T_{L4}} + \frac{\Delta P_V - \Delta P_B}{P_A - P_{V,A}} > 0 \quad (1-5)$$

where:

$$\Delta T_V = \left(1 - \frac{0.8}{2.2 (H_S/D) + 1.9} \right) \Delta T_A + \frac{0.042 \alpha_R I + 0.026 (H_S/D) \alpha_S I}{2.2 (H_S/D) + 1.9} \quad (1-6)$$

For Port Arthur, TX in April, T_{AX} equals 77.3°F, T_{AN} equals 60.1°F, and I equals 1,646 Btu/ft² d per Table 7.1-7.

$$\Delta T_V = (1 - (0.8 / (2.2 (40/120) + 1.9))) (77.3 - 60.1) + (0.042 * 0.25 * 1646 + 0.026 * 40/120 * 0.25 * 1646) / (2.2 * 40/120 + 1.9)$$

$$= 19.9 \text{ }^\circ\text{R}$$

$$\Delta P_V = P_{VX} - P_{VN}$$

P_{VX} and P_{VN} are the true vapor pressures at T_{LX} and T_{LN}, respectively. From Figure 7.1-17:

$$\begin{aligned}
T_{LX} &= T_{LA} + 0.25 \Delta T_V = 528.37 \text{ R} + 0.25 (19.9) = 533.3^\circ\text{R} \\
T_{LN} &= T_{LA} - 0.25 \Delta T_V = 528.37 \text{ R} - 0.25 (19.9) = 523.4^\circ\text{R} \\
P_{VX} &= 8.17 \text{ psia} \\
P_{VN} &= 6.81 \text{ psia} \\
\Delta P_V &= (8.17 - 6.81) = 1.36 \text{ psi} \\
K_E &= 19.9/528.37 + (1.36-0)/(14.68-7.47) \\
K_E &= 0.226
\end{aligned}$$

Solve for K_S :

$$K_S = \frac{1}{1 + 0.053 P_V H_{V0}} \quad (1-23)$$

where:

$$\begin{aligned}
P_V &= 7.47 \text{ psia} \\
H_{V0} &= 2 \text{ feet}
\end{aligned}$$

$$K_S = \frac{1}{1 + 0.053 (7.47)(2)} = 0.558$$

then:

$$\begin{aligned}
C_{sf} &= 1 - \left(\frac{(0.62 * 1 * 120 * 0.176 * 66) - (1 * 0.226 \left(\frac{7.47 * 22,619}{10.731 * 528.37} \right) * 66 * 0.558)}{(1 * 0.226 * \left(\frac{7.47 * 22,619}{10.731 * 528.37} \right) * 66 * 0.558) + \left(\left(\frac{7.47 * 22,619}{10.731 * 528.37} \right) * 66 * 0.60 \right)} \right) \\
&= 0.572
\end{aligned}$$

5. Calculate mole fractions in the liquid. The mole fraction of benzene in the liquid can be calculated using Raoult's Law. The molecular weight of the liquid stock is given as 92 lb/lb-mole, and thus liquid mole fractions of individual components can be calculated using Equation 40-4.

$$x_i = \frac{Z_{Li} M_L}{M_i}$$

$$x_i = \frac{(0.005)(92)}{78.1} = 0.0059 \text{ for benzene}$$

6. Calculate partial pressures and total vapor pressure of the liquid. The total vapor pressure of gasoline RVP 12 and of gasoline RVP 7 is given in Step 4.

For gasoline RVP 12, the calculated value of P_{VA} is:

$$P_V = 7.47 \text{ psia at } 68.7^\circ\text{F}$$

For gasoline RVP 7.0, the calculated value of P_{VA} is:

$$P_V = 4.15 \text{ psia at } 68.7^\circ\text{F}$$

From Table 7.1-7, $P_A = 14.68$ psi

The vapor pressure of benzene at 68.7°F can be determined using Antoine's equation. Since Raoult's Law is assumed to apply in this example, the partial pressure of benzene is the liquid mole fraction (x_i) times the vapor pressure of benzene (P), from Equation 40-3.

| Component | P at 68.7°F | x_i | P_{partial} |
|-----------|---------------------------|--------|----------------------|
| Benzene | 1.484 | 0.0059 | 0.0088 |

7. Calculate mole fractions of components in the vapor. The mole fraction of benzene in the vapor phase is the partial pressure of the component (P_{partial}) divided by the total vapor pressure of the mixture (P_V), from Equation 40-5. The total pressure depends upon the RVP, and thus the mole fraction of benzene must be calculated separately for gasoline RVP 12 and for gasoline RVP 7.0.

$$y_i = P_{\text{partial}}/P_{VA}$$

RVP 12

$$y_i = 0.0088 / 7.47 = 0.0012 \text{ for benzene}$$

RVP 7

$$y_i = 0.0088 / 4.15 = 0.0021 \text{ for benzene}$$

8. Calculate molecular weight of the vapor. This step is not required because the molecular weight of gasoline vapor is already specified.

9. Calculate weight fractions of components of the vapor. The weight fraction of each component in the vapor phase can be calculated using Equation 40-6.

$$Z_{Vi} = \frac{y_i M_i}{M_V}$$

RVP 12

$$Z_{Vi} = \frac{(0.0012)(78.1)}{66}$$

$$Z_{Vi} = 0.0014 \text{ for benzene}$$

RVP 7

$$Z_{Vi} = \frac{(0.0021)(78.1)}{68}$$

$$Z_{Vi} = 0.0024 \text{ for benzene}$$

10. Calculate standing idle loss.

a. Check the limit on standing idle loss:

$$L_{SLmax} \leq 5.9 D^2 h_{ie} W_L$$

$$L_{SLmax} \leq \pi/4 * 7.48 (120)^2 (1) (5.6) = 473,700 \text{ lb}$$

b. Check the calculated standing idle loss:

$$L_{SLwind} = 0.62 n_d D P^* M_V$$

$$L_{SLwind} = 0.62 (3) (120) (0.176) (66) = 2,579 \text{ lb} < 473,700 \text{ lb}$$

$$L_{SLwind} = 2,579 \text{ lb}$$

c. Calculate the benzene standing idle loss:

$$L_{SLbenzene} = 2,579(0.0014) \text{ lb benzene}$$

$$L_{SLbenzene} = 3.6 \text{ lb benzene}$$

11. Calculate the filling loss.

a. Check the limit on filling loss:

$$L_{FLmax} \leq (5.9 D^2 h_{ie} W_L) - L_{SL} + 0.15 (P_{VA} V_V / R T_V) M_V$$

$$L_{FLmax} \leq 5.9 (120)^2 (1) (5.6) - 2,579 + 0.15 [(4.15)(22,619)] / [(10.731)(528.37)] (68) = 471,332 \text{ lb}$$

b. Check the calculated filling loss:

$$L_{FL} = \left(\frac{P_V V_V}{R T_V} \right) M_V (C_{sf} S)$$

The prior stock was gasoline having an RVP of 12, and the roof was refloated with gasoline having an RVP of 7.0. It may be reasonably assumed that the arrival vapors were remaining from the prior stock, and the generated vapors were from the incoming stock. The vapor saturation factor for incoming vapors is 0.15 per the discussion on drain-dry tanks in section 7.1.3.3.2.

Check the total wind-corrected saturation factor for refilling of a landed external floating roof, using the value for C_{sf} calculated in Step 4:

$$C_{sf} S = (0.572) (0.60) = 0.34$$

Given the saturation factor of 0.15 for the generated vapors, the saturation factor for the arrival vapors is therefore $(0.34 - 0.15) = 0.19$.

Calculate the arrival loss:

$$L_{FL}(\text{arrival}) = \left(\frac{7.47 \cdot 22,619}{10.731 \cdot 528.37} \right) \cdot 66 \cdot 0.19$$
$$= 380 \text{ lb}$$

Calculate the generated loss:

$$L_{FL}(\text{generated}) = \left(\frac{4.15 \cdot 22,619}{10.731 \cdot 528.37} \right) \cdot 68 \cdot 0.15$$
$$= 169 \text{ lb}$$

Calculate the total filling loss:

$$L_{FL} = 380 + 169 = 549 \text{ lb} < 471,332 \text{ lb}$$

$$L_{FL} = 548 \text{ lb}$$

- c. Calculate the benzene filling loss: Apply the vapor weight fraction of RVP 12 gasoline to the arrival loss and the vapor weight fraction of RVP 7 gasoline to the generated loss.

$$L_{FL\text{benzene}} = 380(0.0014) + 169(0.0024) \text{ lb benzene}$$

$$L_{FL\text{benzene}} = 0.9 \text{ lb benzene}$$

12. Calculate total losses for the floating roof landing event. The total loss is the sum of the standing loss and the filling loss.

$$L_{TL} = L_{SL} + L_{FL}$$

$$L_{TL} = 2,579 + 548 = 3,126 \text{ lb}$$

$$L_{TL\text{benzene}} = 3.6 + 0.9 = 4.5 \text{ lb benzene}$$

Example 6 – Cleaning Loss for an External Floating Roof Tank

Calculate emissions for cleaning the tank mentioned in Example 5, assuming that tank cleaning operations began on the third day after the floating roof was landed, rather than the tank having been refilled as described in Example 5.

Assume that on the third day of the floating roof landing, forced ventilation was started up to vent the vapor space to a control device which had a vapor reduction efficiency of 95%. Commencement of forced ventilation marked the end of the floating roof landing and the beginning of the tank cleaning event. The one-foot heel of remaining gasoline described in Example 5 was removed by means of vacuum trucks. The amount of gasoline then remaining in puddles in the bottom of the tank was judged to be the equivalent of about one-eighth of an inch deep if it were spread evenly over the bottom of the tank, and about three inches of gasoline remained in the bottom of a 24-inch diameter sump. The equivalent of six inches of diesel was then added to the tank. The forced ventilation continued to be operated at 3,000 cubic feet per minute (cfm) throughout the day and night of the first day of tank cleaning. Methane is used as the calibration gas.

The next morning, the beginning of the second day of tank cleaning, the vapor concentration was found to be less than 10,000 ppmv. At this time the mixture of diesel and gasoline in the bottom of the tank was vacuumed out, leaving an average of about one-half inch of wet sludge remaining on the tank bottom. The control device was disconnected and forced ventilation continued through the second day of tank cleaning, venting directly to atmosphere, as workers cleaned out the sludge. At the end of the second day of tank cleaning, the vapor concentration was measured at 3,800 ppmv and the forced ventilation was turned off overnight. The equivalent of about one-eighth inch of wet sludge remained in the bottom of the tank.

The forced ventilation was restarted on the morning of the third day of tank cleaning, venting to atmosphere. Workers rinsed the tank bottom and removed all remaining volatile material, leaving the tank clean and gas free by the end of the day. At this point, the tank cleaning operation was deemed to be complete from an emissions estimating viewpoint, and the tank was deemed to be out of service. While forced ventilation was continued on subsequent days for the safety of workers inspecting the tank, emissions had ceased due to the removal of all volatile material.

The tank cleaning events and hourly readings of vapor concentration are listed below:

| <u>Day</u> | <u>Time</u> | <u>Hourly Concentration (ppmv)</u> | <u>Daily Activity Concentration (ppmv)</u> |
|------------|-------------|--|--|
| 1 | 10:00 | 380,000 | Start up forced ventilation to control device. Vacuum out gasoline heel. Begin pumping in diesel. First hour is considered vapor space purge. |
| | 11:00 | 190,000 | Continued forced ventilation, routed to control device. |
| | 12:00 | 130,000 | |
| | 13:00 | 101,000 | |
| | 14:00 | 85,000 | |
| | 15:00 | 73,000 | |

| <u>Day</u> | <u>Time</u> | <u>Hourly Concentration</u> (ppmv) | <u>Daily Activity</u> <u>Concentration</u> (ppmv) |
|------------|-------------|---------------------------------------|--|
| | 16:00 | 63,000 | |
| | 17:00 | 53,500 | |
| | 18:00 | 46,000 | |
| | 19:00 | 40,000 | |
| | 20:00 | 35,000 | |
| | 21:00 | 31,000 | |
| | 22:00 | 27,700 | |
| | 23:00 | 24,700 | |
| | 0:00 | 22,000 | |
| | 1:00 | 19,700 | |
| | 2:00 | 17,700 | |
| | 3:00 | 16,000 | |
| | 4:00 | 14,400 | |
| | 5:00 | 12,900 | |
| | 6:00 | 11,500 | |
| | 7:00 | 10,200 | |
| | 8:00 | 9,100 | |
| | 9:00 | 8,200 | 45,300 ppmv, average for first day of continued forced ventilation. Disconnect control device. Vacuum out all free flowing liquid. |
| 2 | 10:00 | 7,400 | Continued forced ventilation, vented to atmosphere. |
| | 11:00 | 6,700 | |
| | 12:00 | 6,100 | |
| | 13:00 | 5,550 | |
| | 14:00 | 5,100 | |
| | 15:00 | 4,700 | |
| | 16:00 | 4,350 | |
| | 17:00 | 4,050 | |
| | 18:00 | 3,800 | 5,300 ppmv, average for second day of continued forced ventilation. Forced ventilation turned off. |
| 3 | 6:00 | 19,000 | Re-start of forced ventilation (to atmosphere). First hour is considered vapor space purge. |
| | 7:00 | 10,100 | Continued forced ventilation, vented to atmosphere, |
| | 8:00 | 5,500 | |
| | 9:00 | 3,800 | |
| | 10:00 | 2,200 | |
| | 11:00 | 1,500 | |
| | 12:00 | 1,050 | |
| | 13:00 | 700 | |
| | 14:00 | 400 | |
| | 15:00 | 150 | |
| | 16:00 | 0 | |

| <u>Day</u> | <u>Time</u> | <u>Hourly Concentration</u> (ppmv) | <u>Daily Activity</u> <u>Concentration</u> (ppmv) |
|------------|-------------|---------------------------------------|---|
| | 17:00 | 0 | |
| | 18:00 | 0 | 2,100 ppmv, average for third day of continued forced ventilation. Tank cleaning is complete; forced ventilation may continue for worker safety during inspections, but all volatile material has been removed and the tank is deemed out of service. |

Example 6 Solution:

1. Select equations to be used.

$$L_{FV} = L_p + L_{CV} \quad (4-1)$$

$$L_p = \left(\frac{P_{VA} V_V}{R T_V} \right) M_V S \quad (4-2)$$

$$L_{CV} = 60 Q_V n_{CV} t_V C_V \left(\frac{P_a M_{CG}}{R T_V} \right) \leq 5.9 D^2 h_{ie} W_i \quad (4-10, 4-12)$$

$$L_{SR} = 60 Q_V n_{CV} t_V C_V \left(\frac{P_a M_{CG}}{R T_V} \right) \leq 0.49 F_e D^2 d_s W_i \quad (4-10, 4-13)$$

where:

- L_{FV} = total emissions due to forced ventilation during a tank cleaning event, lb
- L_p = vapor space purge emissions associated with the first air change following commencement of forced ventilation, lb
- L_{CV} = emissions from continued forced ventilation following the first air change, lb
- P_V = the true vapor pressure of the exposed volatile material in the tank (psia)
- V_V = volume (ft³) of the vapor space
- R = the ideal gas constant (psia ft³ per lb-mole °R)
= 10.731 psia ft³ per lb-mole °R
- T_V = the average temperature of the vapor space (°R)
= the average ambient temperature (°R),
- M_V = the stock vapor molecular weight (lb/lb-mole)
- S = the vapor space saturation factor during the initial vapor space purge (dimensionless)
- 60 = the conversion of hours to minutes, min/hr
- Q_V = average ventilation rate during continued forced ventilation, ft³/min
- n_{CV} = the duration of continued forced ventilation, days
- t_V = the daily period of forced ventilation, hr/day
- C_V = average vapor concentration by volume during continued forced ventilation, dimensionless

- P_A = atmospheric pressure at the tank location, psia
- M_{CG} = calibration gas molecular weight, lb/lb-mole
- D = the tank diameter, feet
- h_{le} = the effective height of the stock liquid and sludge for the given stage of continued forced ventilation, ft
- W_L = the density of the stock liquid, pounds per gallon
- 5.9 = combination of constants ($\pi/4$) and 7.48 gal/ft³
- F_e = the fraction of the sludge that evaporates (= 0.20 if unknown)
- d_s = the average depth of sludge, inches

2. Identify parameters to be calculated/determined from tables. In this example, the following parameters are not specified: P_{VA} , V_V , T_V , M_V , S , M_{CG} , and W_L .

The following values are obtained from tables or assumptions:

- P_V = 7.47 psia for the RVP 12 gasoline, from Example 5.
- V_V = 22,620 ft³ for the initial condition of one foot of stock remaining, from Example 5.
- T_V = 68.7 °F (528.37 °R), from Example 5.
- M_V = 66 lb/lb-mole for gasoline, from Table 7.1-2.
- S = 0.37 from Example 5.
- M_{CG} = 16 lb/lb-mole for methane, from Table 7.1-3.
- W_L = 5.6 lb/gal for gasoline and 7.1 lb/gal for diesel, from Table 7.1-2.

3. Calculate the initial vapor space purge emissions.

$$L_P = \left(\frac{P_{VA} V_V}{R T_V} \right) M_V S$$

$$L_P = \left(\frac{7.47 \cdot 22,620}{10.731 \cdot 528.4} \right) \cdot 66 \cdot 0.37 = 730 \text{ lb}$$

The vapor space purge emissions were routed to a control device having an efficiency of 95%, and thus the net vapor space purge emissions are calculated as follows:

$$L_{P1} = 730 (1 - 0.95) = 37 \text{ lb}$$

4. Calculate first day of continued ventilation emissions (routed to control device).

a. Check the limit on continued ventilation emissions for the first day:

Calculate the mass of liquid remaining in the tank after vacuuming out the one foot of remaining gasoline and flooding the tank bottom with diesel.

The remaining gasoline is the equivalent of one-eighth of an inch across the entire bottom of the tank, plus 3 inches in a 24-inch diameter sump.

Equivalent depth of the liquid in the sump, if spread across the entire tank bottom:

$$(3 \text{ inches}/12) * (\pi (24/12)^2/4) / (\pi 120^2/4) = 0.0007 \text{ inches}$$

Total effective depth of gasoline remaining in the bottom of the tank:

$$(0.125 \text{ inches}) + (0.0007 \text{ inches}) = 0.1257 \text{ inches} = 0.010 \text{ feet}$$

The depth of diesel in the bottom of the tank is: 6 inches = 0.5 feet

$$L_{CVmax} \leq 5.9 D^2 h_{le} W_L$$

$$L_{CVmax} \leq 5.9 (120)^2 (0.010 \times 5.6 + 0.5 \times 7.1) = 310,000 \text{ lb}$$

b. Check the calculated continued ventilation emissions for the first day:

$$L_{CV} = 60 Q_V n_{CV} t_V C_V \left(\frac{P_a M_{CG}}{R T_V} \right)$$

$$L_{CV} = 60 \cdot 3,000 \cdot 1 \cdot 24 \cdot \left(\frac{45,300}{1,000,000} \right) \cdot \left(\frac{14.68 \cdot 16}{10.731 \cdot 528.4} \right) = 8,100 \text{ lb} < 310,000 \text{ lb}$$

$$L_{CV1} = 8,100 \text{ lb}$$

The first day of continued ventilation emissions were routed to a control device having an efficiency of 95%, and thus the net vapor space purge emissions are calculated as follows:

$$L_{CV1} = 8,100 (1 - 0.95) = 410 \text{ lb}$$

5. Calculate the second day vapor space purge emissions.

The forced ventilation ran throughout the night on the first day of tank cleaning, and thus there was no standing idle period during which vapors could build up in the vapor space, and there were no vapor space purge emissions on the morning of the second day of tank cleaning.

$$L_{P2} = 0 \text{ lb}$$

6. Calculate second day of continued ventilation emissions (routed directly to atmosphere).

a. Check the limit on continued ventilation emissions for the second day:

Calculate the mass of liquid remaining in the tank after vacuuming out all free flowing liquid and leaving one-half inch of wet sludge in the bottom of the tank.

$$LCV \leq 0.49 F_e D^2 d_s W_l$$

where:

F_e = the fraction of the sludge that evaporates (= 0.20 if unknown)

D = the tank diameter, feet

d_s = the average depth of sludge, inches

W_L = the density of the stock liquid, pounds per gallon

the constant, 0.49, has units of gal/(in. ft²), and the other terms are defined as shown above.

In the liquid phase, the density of diesel is greater than the density of gasoline and, as shown in the calculations above for the first day, most of the remaining liquid is diesel. It would, then, be both reasonable and conservative to use the density of diesel in calculating the mass of remaining liquid.

$$L_{CV} \leq 0.49 (0.20) (120)^2 (0.5) (7.1) = 5,000 \text{ pounds}$$

b. Check the calculated continued ventilation emissions for the second day:

$$L_{CV} = 60 Q_V n_{CV} t_V C_V \left(\frac{P_a M_{CG}}{RT_V} \right)$$

$$L_{CV} = 60 \cdot 3,000 \cdot 1 \cdot 9 \cdot \left(\frac{5,300}{1,000,000} \right) \cdot \left(\frac{14.68 \cdot 16}{10.731 \cdot 528.4} \right) = 360 \text{ lb} < 5,000 \text{ lb}$$

$$L_{CV2} = 360 \text{ lb}$$

The second day of continued ventilation emissions were routed directly to atmosphere, and thus the net vapor space purge emissions are calculated as follows:

$$L_{CV2} = 360 (1 - 0.0) = 360 \text{ lb}$$

7. Calculate the third (last) day vapor space purge emissions.

The forced ventilation was discontinued overnight between the second and third days of tank cleaning, and thus there was an overnight standing idle period. There would, then, be a vapor space purge on the morning of the third day of tank cleaning. Note that C_{sf} is set to 1.0 for subsequent vapor space purges that follow ventilation having been shut off overnight. The vapors originated from a mixture of diesel and gasoline. While most of the liquid was pumped out during the second day, the relative volumes of diesel and gasoline would have been as described above for the limit on continued ventilation emissions for the first day. The effective depths were 0.01 feet for gasoline and 0.5 feet for diesel, for a total initial depth of 0.51 feet. The volumes are then calculated from the liquid depths and the diameter of the tank:

$$\text{Gasoline: } 0.01 (\pi)(120)^2 / 4 = 113 \text{ ft}^3$$

$$\text{Diesel: } 0.50 (\pi)(120)^2 / 4 = 5,655 \text{ ft}^3$$

Multiply the volumes of each liquid by its liquid density to calculate the mass of each. Values of 5.6 lb/gal for gasoline and 7.1 lb/gal for diesel are obtained from Table 7.1-2.

$$\text{Gasoline: } 113 (5.6) (7.48) = 4,733 \text{ lb}$$

$$\text{Diesel: } 5,655 (7.1) (7.48) = 300,326 \text{ lb}$$

The conversion factor of 7.48 has units of gallons per cubic foot.

The total weight is $4,733 + 300,326 = 305,059$ lb. The weight of each liquid may then be divided by the liquid phase molecular weight to calculate the number of moles of that liquid. Molecular weights are obtained from Table 7.1-2.

$$\text{Gasoline: } 4,733 / 92 = 51$$

$$\text{Diesel: } 300,326 / 188 = 1,597$$

The total number of moles is $(51 + 1,597) = 1,648$, and the mole (volume) fractions in the liquid phase may be calculated:

$$\text{Gasoline: } 51 / 1,648 = 0.031$$

$$\text{Diesel: } 1,597 / 1,648 = 0.969$$

From Example 5, the temperature at the bottom of the tank is 68.7 F, and the true vapor pressure of the gasoline at that temperature is 7.47 psia. Calculate the true vapor pressure of the diesel at 68.7 F, using Equation 1-27 with values for the A and B constants from Table 7.1-2.

$$P = \exp \left[A - \frac{B}{T} \right]$$

$$A = 12.101$$

$$B = 8,907 \text{ } ^\circ\text{R}$$

$$P = 0.0086 \text{ psia}$$

The partial pressure of each component is the liquid mole (volume) fraction times the true vapor pressure:

$$\text{Gasoline: } 0.031 * 7.47 = 0.232 \text{ psia}$$

$$\text{Diesel: } 0.969 * 0.0086 = 0.0083 \text{ psia}$$

The vapor space purge emissions for the third day can then be computed separately for each component:

$$L_P = \left(\frac{P_V A_V V_V}{R T_V} \right) M_V S$$

where:

P_V = the partial pressure of the given component, psia

V_V = the volume under the landed floating roof, cubic feet

Determine the vapor space volume V_V using Equation 3-22, where the height of the vapor space under the floating roof is the floating roof leg height (neglecting the one-eighth inch height of sludge remaining in the tank). In that this example is a continuation of the floating roof landing in Example 5, the leg height is given as 3 feet. However, it is more common for the legs to be set in the high leg position when cleaning the tank.

$$V_V = (3) (\pi 120^2/4) = 33,930 \text{ ft}^3$$

$$R = 10.731 \text{ psia ft}^3 \text{ per lb-mole } ^\circ\text{R}$$

$$T_V = \text{temperature } ^\circ\text{R} = 68.7 + 459.67 = 528.4$$

M_V = vapor phase molecular weight of the given component, from Table 7.1-2

Gasoline: 66

Diesel; 130

S = saturation factor = 0.50 from 7.1.3.4.1 for only wet sludge remaining

$$L_{P_{gasoline}} = \left(\frac{0.232 \cdot 33,930}{10.731 \cdot 528.4} \right) \cdot 66 \cdot 0.50 = 46 \text{ lb}$$

$$L_{P_{diesel}} = \left(\frac{0.0083 \cdot 33,930}{10.731 \cdot 528.4} \right) \cdot 130 \cdot 0.50 = 3 \text{ lb}$$

$$L_{P3} = 46 + 3 = 49 \text{ lb}$$

8. Calculate third (last) day of continued ventilation emissions (routed directly to atmosphere).

a. Check the limit on continued ventilation emissions for the last stage:

After a day of removing sludge, about one-eighth inch of sludge remained in the bottom of the tank.

$$L_{CV_{max}} \leq 0.49 F_e D^2 d_s W_L$$

$$L_{CV_{max}} \leq 0.49 (0.20) (120)^2 (0.125) (7.1) = 1,300 \text{ lb}$$

b. Check the calculated continued ventilation emissions for the last day:

$$L_{CV} = 60 Q_V n_{CV} t_V C_V \left(\frac{P_a M_{CG}}{R T_V} \right)$$

$$L_{CV} = 60 \cdot 3,000 \cdot 1 \cdot 12 \cdot \left(\frac{2,100}{1,000,000} \right) \cdot \left(\frac{14.68 \cdot 16}{10.731 \cdot 5284} \right)$$

$$L_{CV3} = 190 \text{ lb} < 1,300 \text{ lb}$$

The last day of continued ventilation emissions were routed directly to atmosphere, and thus the net vapor space purge emissions are calculated as follows:

$$L_{CV3} = 190 (1 - 0.0) = 190 \text{ lb}$$

9. Calculate total losses for the tank cleaning event. The total loss is the sum of the vapor space purge emissions and the continued ventilation emissions for each day of forced ventilation while volatile material remained in the tank. These emissions are summarized as follows:

| | L_P | L_{CV} |
|-------|-------|----------|
| Day 1 | 37 | 410 |
| Day 2 | 0 | 360 |

| | L_p | L_{cv} |
|-------|-------|----------|
| Day 3 | 49 | 190 |
| Total | 86 | 960 |

The total emissions during tank cleaning (forced ventilation) are then:

$$L_{FV} = L_p + L_{cv}$$

$$L_{FV} = 86 + 960 = 1,000 \text{ lb}$$

Note that emissions from this example were significantly mitigated by the flushing of the tank bottom with diesel to reduce the vapor concentration relatively quickly, and by the routing of vapors to a control device until the vapor concentration was reduced substantially (comparing the start of day 2 to the start of day 1 shows that the vapor concentration when the control device was disconnected was about two percent of the initial reading). It's evident from step 4.b above that emissions would have been several tons per day if these mitigation steps had not been taken.

7.1.8 Historical Equations

Equations in this section were historically used to obtain approximate values but have been replaced with more accurate equations.

7.1.8.1 Average Daily Vapor Pressure Range

The following method was historically available for approximating ΔP_V , with some loss of accuracy, however it is no longer recommended.

$$\Delta P_V = \frac{0.50 B P_{VA} \Delta T_V}{T_{LA}^2} \quad (60-1)$$

where:

ΔP_V = average daily vapor pressure range, psia

B = constant in the vapor pressure equation, °R; the value used here must be the B constant for the two-constant expression in Equation 1-27

P_{VA} = vapor pressure at the average daily liquid surface temperature, psia; see Notes 1 and 2 to Equation 1-24

T_{LA} = average daily liquid surface temperature, °R; see Note 3 to Equation 1-24

ΔT_V = average daily vapor temperature range, °R; see Note 1 to Equation 1-5

7.1.8.2 Fixed Roof Tank Working Loss

Working loss for fixed roof tanks had historically been estimated using Equation 60-2. The temperature for purposes of determining the vapor density was assumed to be 63°F (523°R) in Equation 60-2, and thus the vapor density was represented as $(M_V P_{VA})/(10.731 \cdot 523)$. The coefficient of 0.0010 was based on this simplification of the vapor density, combined with the 5.614 term for converting barrels to cubic feet, resulting in $(5.614)/(10.731 \cdot 523) = 0.0010$.

$$L_W = 0.0010 M_V P_{VA} Q K_N K_P \quad (60-2)$$

where:

L_W = working loss, lb/yr

M_V = vapor molecular weight, lb/lb-mole; see Note 1 to Equation 1-24

P_{VA} = vapor pressure at average daily liquid surface temperature, psia; see Note 1 to Equation 1-24 and Note 2 to Equation 1-24

Q = annual net throughput (tank capacity [bbl] times annual turnover rate), bbl/yr

K_N = working loss turnover (saturation) factor, dimensionless

for turnovers >36, $K_N = (180 + N)/6N$

for turnovers ≤36, $K_N = 1$

N = number of turnovers per year, dimensionless

$$N = \frac{5.614Q}{V_{LX}} \quad (60-3)$$

where:

V_{LX} = tank maximum liquid volume, ft³

$$V_{LX} = \frac{\pi}{4} D^2 H_{LX} \quad (60-4)$$

where:

D = diameter, ft

H_{LX} = maximum liquid height, ft

K_p = working loss product factor, dimensionless

for crude oils, $K_p = 0.75$

for all other organic liquids, $K_p = 1$

REFERENCES FOR SECTION 7.1

1. Laverman, R.J., *Emission Reduction Options For Floating Roof Tanks*, Chicago Bridge and Iron Technical Services Company, Presented at the Energy Week 1996, Conference on Pipelines, Terminals and Storage, George R. Brown Convention Center Houston, TX, January 29 – February 2, 1996.
2. *VOC Emissions From Volatile Organic Liquid Storage Tanks-Background Information For Proposed Standards*, EPA-450/3-81-003a, U. S. Environmental Protection Agency, Research Triangle Park, NC, July 1984.
3. Alternative Control Techniques Document: Volatile Organic Liquid Storage in Floating and Fixed Roof Tanks, EPA-453/R-94-001, U. S. Environmental Protection Agency, Research Triangle Park, NC, January 1994.
4. Evaporation Loss From Internal Floating Roof Tanks, Third Edition, Publication Bulletin No. 2519, American Petroleum Institute, Washington, DC, June 1983.
5. Evaporative Loss from Floating-Roof Tanks, Manual of Petroleum Measurement Standards, Chapter 19.2, Third Edition, American Petroleum Institute, Washington, D.C., October 2012.
6. [Reserved]
7. *Benzene Emissions From Benzene Storage Tanks-Background Information For Proposed Standards*, EPA-450/3-80-034a, U. S. Environmental Protection Agency, Research Triangle Park, NC, December 1980.
8. Evaporative Loss from Fixed-Roof Tanks, Manual of Petroleum Measurement Standards, Chapter 19.1, Fifth Edition, American Petroleum Institute, Washington, D.C., June 2017.
9. *Estimating Air Toxics Emissions From Organic Liquid Storage Tanks*, EPA-450/4-88-004, U. S. Environmental Protection Agency, Research Triangle Park, NC, October 1988.
10. Barnett, H.C., *et al.*, *Properties Of Aircraft Fuels*, NACA-TN 3276, Lewis Flight Propulsion Laboratory, Cleveland, OH, August 1956.
11. Petrochemical Evaporation Loss From Storage Tanks, First Edition, Bulletin No. 2523, American Petroleum Institute, Washington, D.C., 1969.
12. *SIMS Data Base Management System*, Version 2.0, U. S. Environmental Protection Agency, Research Triangle Park, NC, 1990.
13. [Reserved]
14. *National Solar Radiation Data Base, 1991-2010*, prepared by National Renewable Energy Laboratory (NREL), Golden, CO, 2012. https://rredc.nrel.gov/solar/old_data/nsrdb/1991-2010/hourly/list_by_state.html. Data that were used to calculate the meteorological data contained in Table 7.1-7 are no longer available at the previous address, but new data are available here: <https://www.ncei.noaa.gov/products/land-based-station/national-solar-radiation-database>.
15. Ferry, R.L., Documentation Of Rim Seal Loss Factors For The Manual Of Petroleum Measurement Standards: Chapter 19--Evaporative Loss Measurement: Section 2--Evaporative Loss From Floating Roof Tanks, preliminary draft, American Petroleum Institute, April 5, 1995.
16. Written communication from R. Jones, et al., Midwest Research Institute, to D. Beauregard, U. S. Environmental Protection Agency, Final Fitting Loss Factors For Internal And External Floating Roof Tanks, May 24, 1995.

17. Written communication from A. Parker and R. Neulicht, Midwest Research Institute, to D. Beauregard, U. S. Environmental Protection Agency, Fitting Wind Speed Correction Factor For External Floating Roof Tanks, September 22, 1995.
18. Use Of Variable Vapor Space Systems To Reduce Evaporation Loss, Bulletin No. 2520, American Petroleum Institute, New York, NY, 1964.
19. Written communication from A. Parker, Midwest Research Institute, to D. Beauregard, U. S. Environmental Protection Agency, Final Deck Fitting Loss Factors for AP-42 Section 7.1, February 23, 1996.
20. Courtesy of R. Ferry, TGB Partnership, Hurdle Mills, NC.
21. Evaporative Loss from Storage Tank Floating Roof Landings, Manual of Petroleum Measurement Standards, Chapter 19.6, Part 1, First Edition, Technical Report 2567, American Petroleum Institute, Washington, D.C., February 2017.
22. Evaporative Loss Reference Information and Speciation Methodology, Manual of Petroleum Measurement Standards, Chapter 19.4, Third Edition, Addendum 3, American Petroleum Institute, Washington, D.C., October 2023.
23. Evaporative Loss from the Cleaning of Storage Tanks, Technical Report 2568, American Petroleum Institute, Washington, D.C., November 2007.
24. Ferry, R.L., Distillate Flushing Study – Bench and Field Testing – Final Report, prepared for the American Petroleum Institute, March 2014.
25. 2016 Emissions Inventory Guidelines, RG-360/16, Appendix A, Technical Supplement 6, Texas Commission on Environmental Quality, Austin, TX, January 2017.
26. Short-term Evaporative Loss Estimation from Atmospheric Storage Tanks, Technical Report 2576, First Edition, American Petroleum Institute, Washington, D.C., July 2016.
27. Evaporative Loss from Closed-vent Internal Floating-roof Storage Tanks, Technical Report 2569, American Petroleum Institute, Washington, D.C., August 2008.
28. *Guide to Fire Hazard Properties of Flammable Liquids, Gases, and Volatile Solids*, NFPA 325, 1994 edition, National Fire Protection Institute, Quincy, MA, 1994.
29. California Air Resources Board. Technical Guidance Document for the Emission Inventory Criteria and Guidelines Regulation for AB 2588, August 1989.
30. Chemistry and Chemical Reactivity, Kotz and Treichel, Saunders College Publishing, Fourth Edition, 1999, page 658.

Available references can be found here: <https://gaftp.epa.gov/ap42/ch07/s01/reference/>

Some references on this website are the property of the American Petroleum Institute (API). These materials may be protected by Copyright Law (Title 17 US Code). To access a specific reference, take the following steps:

1. Go to this website: <http://publications.api.org/>.
2. Create an account and login.
3. Accept the terms of use.
4. Select "Browse read-only documents".
5. Select "IBR Documents under Consideration".
6. Seek your reference of interest.